

FOR YOU SAFTEY

If you have a Fuel Oil leak:

1. Open windows
2. **DO NOT** try to light any appliance.
3. **DO NOT** use electrical equipment.
4. Shut off Fuel Oil supply.
5. Leave the building.
6. Immediately call your local Fuel Oil supplier after leaving the building. Follow Fuel Oil supplier's instructions.
7. If you cannot reach your Fuel Oil supplier, call the Fire Department.

⚠ WARNING



Fire Hazard

Do not store or use gasoline or other flammable vapors and liquids in the vicinity of this or any other appliance.

Some objects will catch fire or explode when placed near this heater.

Failure to follow these instructions can result in death, injury or property damage.

Reflect-O-Ray®

Oil Fired EDS 3.5

Oil fired, Low Intensity Infrared Vacuum Vented Infrared Heating Systems Installation, Operating, Maintenance and Parts Manual

⚠ WARNING

This equipment, its related accessories and by-products of operation, contain chemicals (including carbon monoxide) known to the State of California to cause cancer, birth defects, or other reproductive harm. For more information go to www.P65Warnings.ca.gov



Read and understand these installation, operating and maintenance instructions thoroughly before installing or servicing this equipment. Only trained, qualified gas installation and service personnel may install or service this equipment.

Installer

Please take time to read and understand these instructions prior to any installation. Installer must give a copy of this manual to the owner.

Owner

Keep this manual in a safe place in order to provide your serviceman with the necessary information.



Combustion Research Corp.
 2516 Leach Rd.
 Rochester Hills, MI 48309-3555
 Telephone: 248.852.3611
 Fax: 248.852.9165
www.combustionresearch.com



! WARNING



FIRE OR EXPLOSION HAZARD

Can cause death, severe injury and/or property damage.

1. Read this manual carefully before installing or servicing this equipment. Improper installation, service or maintenance can cause death, injury or property damage.
2. Check clearances listed in each burner to make sure the product is suitable for your application.
3. Installer must be a trained, experienced service technician.
4. All service must be performed only by a trained service technician or representative
5. After installation is complete, check product operation as provided in these instructions.

Combustibles: Failure to maintain the specified minimum clearances to combustibles could result in a serious fire hazard. Do not locate flammable or combustible materials within this distance. Signs should be posted in storage areas to specify maximum stacking height to maintain required clearances to combustibles. Do not locate in hazardous atmospheres containing flammable vapors or combustible dust.

United States: Installations in public garages or airplane hangars are permitted when in accordance with ANSI Z83.20 and NFPA-409 and 88 Codes.

Canada: Installation in public garages is permitted when in accordance with CAN/CSA B149.1 Code. Installation in airplane hangars is permitted when in accordance with the requirements of the enforcing agency.

Ignition: This appliance does not have a pilot. It is equipped with an ignition device, which automatically lights the burner. Do not try to light the burner by hand.

Vehicles: Minimum clearances must be maintained from vehicles parked, below the heater. Ensure that adequate clearance is maintained where vehicles are in operation or being serviced.

Oil Connection: There is an expansion of the radiant pipe With each firing cycle, and this will cause the burner to move with respect to the oil line. This can cause an oil leak resulting in an unsafe condition if the oil connection does not allow for expansion. Installation shall be in made in accordance with installation local and national installation codes.

Mechanical Hazard - Vacuum Exhauster: High speed rotating vacuum exhauster impeller/wheel can cause severe injury. Do not operate exhauster without impeller/wheel. Loose clothing can be drawn into unguarded inlet and entangle with impeller/wheel. Keep hands and fingers away from inlet and outlet. Install exhaust duct with "bird screen" or approved vent cap on vacuum exhauster outlet.

Mechanical Hazard - Suspension: Use appropriate suspension hardware, beam clamps (rod or perforated strap) and turnbuckles at predetermined locations. The weight and normal movement of the heating system may cause support failure if the following minimum suspension requirements are not met. Distance between radiant tube hangers must be 10-ft. (3 M) or less; chain size must be 3/0 minimum or equivalent. **DO NOT** suspend 1/4 hp and larger vacuum exhausters with chain. Failure of the suspension system and associated supports can cause death, severe injury or property damage.

NOTICE

Failure to follow these instructions can cause personal injury or property damage:

Caution should be used when running the system near combustible materials such as wood, paper, rubber, etc. Consideration must be given to partitions, storage racks, hoists, building construction, etc. Page 4 & 5 outlines minimum acceptable clearances to combustibles.

If the building has a negative pressure or contaminants are present in the air, an outside combustion air Supply to the heaters is strongly recommended.

Do not use in an atmosphere containing halogenated hydrocarbons or other corrosive chemicals. Some compounds in the air can be drawn into the equipment and can cause corrosion of some parts of the radiant tube heat exchanger. The use of such chemical compounds in or near the burner enclosure should be avoided where a longer life of the burner, tubing, and other parts is desirable.

If this heating appliance and associated hardware is used in agricultural structures which support life were failure of this appliance could result in loss or injury, the user should provide an adequate back-up system and a failure alarm system. The user must accept the risk of such loss or injury from the failure of the heating system.

! CAUTION

This appliance could expose you to substances in fuel or from fuel, which have been determined by the State of California to cause cancer, birth defects, or other reproductive harm.

Failure to follow these instructions can cause damage to the system components:

DO NOT high-pressure test the oil piping with the burners connected. Failure to follow this procedure will exceed the pressure rating of burner oil controls and this will **require complete replacement of these parts.**

DO NOT operate a vacuum exhauster with an unrestricted inlet. Operating a vacuum exhauster when not installed in system requires that a damper be installed on the inlet, which is one-half closed. An unrestricted airflow will overload the motor causing burnout or failure.

This heater is designed for heating nonresidential indoor spaces. These instructions, the layout drawing, local codes and ordinances, and applicable standards that apply to oil piping, electrical wiring, venting, etc., must be thoroughly understood before proceeding with the installation.

INSTALLER

PLEASE TAKE TIME TO READ AND UNDERSTAND THESE INSTRUCTIONS PRIOR TO ANY INSTALLATION OR SERVICE. Contact your representative or the factory if you have any questions

OWNER

Retain this manual in a safe place to provide your serviceman with information if the situation arises.

TABLE OF CONTENTS

	PAGE(S)
Warning Symbols	1
Standards, Certifications and Codes	1 & 2
Installer Qualification & Responsibility	2
Installation Notes	3
Tube Length Requirements	3
Vacuum Exhauster Selection	3
Clearance To Combustibles	4 - 6
System Installation	7 - 9
Damper Types	9 & 10
Suspension Methods	11
Seismic Restraint Suspension	12
Reflector Installation	13 - 15
Decorative Grille Installation	16
Radiant Tube Wall Penetration	17
Connecting Burner To Radiant Tube	18
Oil Supply	19
Oil Supply – Day Tank System	20
Oil Supply – “TIGER LOOP” System	21
Flexible Oil Connector Installation	22
Combustion Air	23
Vacuum Exhausters	24
Exhaust Flex Connections	25
Venting	26 – 29
Electrical Wiring & Control Panels	30 – 32
Burner Wiring Schematic	33
Burner Technical & Setup Data	34
Sequence Of Operation & General Safety Information	35 & 36
System Start Up	35 & 36
System Shut Down & Maintenance	36 – 42
Trouble Shooting Flow Chart	43 & 44
Vacuum Exhauster Parts List	46 & 46
Burner Parts List	47 – 49
Accessories & Optional Equipment	50 – 52
Warranty Statement	54 – 55
Sample Clearance To Combustible Warning Sign	57

Reflect-O-Ray® heating systems DO NOT qualify for use in explosion proof installations. Heaters SHALL NOT be used in living/sleeping areas.

Reflect-O-Ray® Oil Fired EDS 3.5 burner assemblies use No. 2 fuel only! WASTE OIL, GASOLINE, CRANKCASE OIL OR ANY OIL CONTAINING GASOLINE OR OTHER TYPES OF OIL IS NOT TO BE USED.

©2018 COMBUSTION RESEARCH CORPORATION, INC.

All rights reserved. No part of this work covered by the copyrights hereon in may be reproduced or copied in any form or by any means - graphic, electronic, or mechanical, including photocopying, recording, taping, or information storage and retrieval systems - without written permission of COMBUSTION RESEARCH CORPORATION, Inc.

This Page Intentionally Left Blank

WARNING SYMBOLS



Warning indicates a potentially hazardous situation which, if not avoided, could result in death or injury.



Caution indicates a potentially hazardous situation which, if not avoided, could result in minor or moderate injury.



Notice indicates a potentially hazardous situation which, if not avoided, could result in property damage.

CHECKING SHIPMENT

Upon receipt of shipment, check shipment against Bill of Lading for shortages. Also check for external damage to cartons or tube bundles. Shortages and/or external damage to cartons or tubes must be noted on the Bill of Lading in the presence of delivery trucker. The delivery trucker should acknowledge any shortages or damage by initialing this "noted" Bill of Lading.

Claims for damaged material, or shortages that were not evident upon receipt of shipment must be reported to carrier and Combustion Research Corporation Sales Representatives within 72 hours.

Before starting to assemble the heater, make sure that all optional and accessory items are accounted for and are available for assembly. It is also important to verify that the correct Btu input burner is supplied for the project.

IMPORTANT



FIRE HAZARD

IMPROPER INSTALLATION CAN CAUSE DEATH, SEVERE INJURY AND/OR PROPERTY DAMAGE.

Read and understand these installation, operating and maintenance instructions thoroughly before installing or servicing this equipment. Only trained, qualified fuel oil installation and service personnel may install or service this equipment.

These instructions, the layout drawing, local codes and ordinances, and applicable standards such as apply to oil piping and electrical wiring must be thoroughly understood before proceeding with the installation.

TESTED UNDER STANDARDS

- AMERICAN STANDARDS** – UL 731-(Current Standard)
- CANADIAN STANDARDS** – CAN/CSA B140.04-(Current Standard)

BUILDING CODES

- In the absence of local codes, the installation must conform to the latest edition of:
 - United States:** National Fuel Gas Code, ANSI Z223.1 (NFPA 54).
 - Canada:** CAN/CSA B139 (current edition) and the Canadian Electrical Code C22.1

AIRCRAFT HANGERS

- Heaters for use in aircraft hangers must be installed in accordance with;
 - United States:** Refer to Standard for Aircraft Hangars, ANSI/NFPA 409 (latest edition).
 - In Canada:** Refer to Standard CAN/CSA B149.1 Code and applicable Standards for Aircraft Hangars.

Basic guidelines are as follows:

1. Suspended heaters in aircraft storage or service areas shall be installed at least ten feet (10') above the upper surface of wings or engine enclosures of the highest aircraft which may be housed in the hanger. This should be measured from the bottom of the heater to the wing or engine enclosure, whichever is highest from the floor.
2. In other sections of aircraft hangers, such as shops or offices communicating with airplane storage or servicing area, heaters shall be installed in accordance with their listings and mounted not less than eight feet (8') above the floor.
3. Heaters installed in aircraft hangers shall be located so as not to be subject to injury by aircraft, cranes, moveable scaffolding or other objects. Provisions shall be made to ensure accessibility to suspended heaters for recurrent maintenance purposes.

PUBLIC GARAGES

- Heaters for use in public garages must be installed in accordance with:
 - United States:** Standard for Parking Structures NFPA 88A (latest edition) or the Code for Motor Fuel Dispensing Facilities and Repair Garages NFPA 30A (latest edition).
 - Canada:** Refer to CAN/CSA B139 (latest edition), Installation Codes and applicable Standards for Public Garages.

Basic guidelines are as follows:

1. Heaters shall be installed in accordance with their listings and not be mounted less than eight feet (8') above the floor. Minimum clearances to combustibles must be maintained from vehicles parked below the heater.
2. When installed over hoists, clearance to combustible material must be maintained from upper most point of the hoist, or provided as insulating or reflective barrier on the hoist (consult representative or factory for guidance).

ELECTRICAL GROUNDING

The burner and vacuum exhauster must be electrically grounded in accordance with the following codes:

United States: Refer to National Electrical Code®, ANSI/NFPA 70 (latest edition). Wiring must conform to the latest edition of National Electrical Code®, local ordinances, and any special diagrams furnished.

Canada: Refer to Canadian Electrical Code CSA C22.1 Part 1 (latest edition).

OIL SUPPLY SYSTEM

The method of pipe sizing must conform to the U.S. National Standards: NFPA 30 & 31 or CAN/CSA B139 (current edition) Installation Code for Oil Burning Equipment, and should be installed in accordance with all National and Local Codes and ordinances.

CLEARANCES AND ACCESSIBILITY

Inlet air assemblies are to be installed with the air opening pointing toward the ground to protect against rain and snow. Inlet is provided with a bird screen. Adequate clearance must be provided around the inlet air assembly opening to provide an unobstructed entry for the combustion air. The air should be taken from outside the building. Clearances must be sufficient to provide accessibility for servicing. The air inlets must be a minimum of six feet (6') from the exhaust port.

AGRICULTURAL INSTALLATIONS

In agricultural installations *Reflect-O-Ray*® heating systems must be installed as vented systems only.

HAZARDOUS LOCATIONS

Where there is the possibility of exposure to combustible airborne materials or vapor, consult the local Fire Marshal, the fire insurance carrier, or other authorities for approval of the proposed installation. ***Reflect-O-Ray*® heating systems DO NOT qualify for use in explosion proof installations.**

INSTALLER QUALIFICATIONS

Only firms or individuals qualified to perform work in accordance with the applicable specifications should be engaged to install a *Reflect-O-Ray*® system. Consult local Building Inspectors, Fire Marshals, or the local applicable Combustion Research Corporation representative for guidance.

INSTALLER RESPONSIBILITY

Reflect-O-Ray® systems are installed on the basis of information given in a layout drawing. Together with these instructions and the cited codes and regulations comprise the information needed to complete the installation. The installer must furnish all needed material that is not furnished as standard *Reflect-O-Ray*® equipment, and it is his responsibility to see that such materials, as well as the

installation methods he uses result in a job that is workman like and in keeping with all applicable codes.

In storage areas where stacking of materials may occur, the installer must provide signs that specify the maximum stacking height so as to maintain the required clearance to combustibles.

GENERAL CONSIDERATIONS

Combustion Research Corporation Factory Representatives are experienced in the application of this equipment and can be called on for suggestions about installation which can give the owner of the building a more satisfactory and economical installation.

When installing the *Reflect-O-Ray*® system, take maximum advantage of the building upper structure, beams, Joists, purlins etc. from which to suspend the system. Mount units at minimum height for ease of installation and maintenance but of specified height to fully utilize the building.

The general lay out of the *Reflect-O-Ray*® heating system has been established by the engineering drawing. The *Reflect-O-Ray*® heaters are used to heat building structures as well as localized areas that would include doors, loading docks and isolated workstations throughout the building. The location of the *Reflect-O-Ray*® heaters should be such that the area is covered uniformly, in that the heat is positioned on the perimeter or to each side of the area to be heated, rather than directly overhead. This will give a better comfort condition for workers who would be in these areas. Consult with your representative or the factory for additional guidance in designing the optimum layout for your project.

Reflect-O-Ray® is a suspended system, which requires that consideration be given to the factors that determine its stability, flexibility, safety, and satisfactory operation. Before installation, the contractor should inspect the building along with the owner (or engineer) responsible for the building to check on the use of the building. Inspection of the building including the use of floor space for storage and height of materials stored in the building must be noted so that there are no problems with clearances to combustibles. Particular care should be taken over doors and high objects such as busses, trucks, cranes, car lifts, etc. Whenever possible use side wall penetrations for combustion air inlets to burners and exhaust venting.

DO -

- **Maintain specified clearances to combustibles, and to heat sensitive material, equipment, and workstations.**
- **Provide approved heat radiation shielding or barriers if needed. Refer to the National Fuel Gas Code for guidance.**
- **Provide access for general servicing; provide easy access for complete removal of burner and blower.**
- **Familiarize yourself with local and national codes. Develop a planned installation procedure, which will conserve material and labor on the job. Check to see that all material and equipment is on the job before starting installation. Be sure to accommodate thermal expansion of the hot tube.**
- **Use the oil connector ONLY as shown in the instructions.**
- **Provide end clearance so tubing won't expand and touch a wall or a structural member.**

INSTALLATION NOTES

A. GENERAL INSTALLATION LAYOUT

1. Height from floor - 10' to 30' (refer to chart for recommended minimum mounting heights). There are no restrictions on the mounting height of the equipment providing the design is based on the full heat loss of the building. Consideration must be given to the building heat loss so as to cover the air infiltration and/or the mechanical ventilation of the building. For serviceability and optimum performance the system should be mounted with careful consideration to the use of the building.

B. RADIANT TUBE ELEMENT LENGTHS FOR STANDARD (OIL FIRED OIL FIRED EDS 3.5) SYSTEMS.

1. To dissipate maximum heat and avoid continuous condensation in the radiant tube elements, each burner will be provided with the minimum or maximum tube lengths as outlined in the following chart. A heavy walled 16 gauge aluminized steel tube (10' -0") long is used adjacent or downstream of each burner. The remainder of the radiant tubing shall be of spiral wound aluminized steel tube. Each single flow of radiant tube shall incorporate an adjustable damper for regulating burner airflow.

2. A multiple burner system consists of two or more burners. Refer to the following charts for radiant tube lengths and elbow and tee placement.

C. RADIANT TUBE ELEMENT LENGTHS FOR HIGH OUTPUT (OIL FIRED OIL FIRED EDS 3.5) SYSTEMS.

1. To dissipate maximum heat and avoid continuous condensation in the radiant tube elements, each burner will be provided with the minimum tube lengths as outlined in the following chart. A heavy walled 16-gauge aluminized steel tube 10' 0" long is used adjacent to each burner. The remainder of the radiant tubing shall be of spiral wound aluminized steel tube. Tee's must be installed after any turbulator tube. Each single flow of radiant tube shall incorporate an adjustable damper for regulating burner airflow. NOTE: The radiant tubes for the *Reflect-O-Ray® OIL FIRED EDS 3.5* systems can and may be heat-treated for optimum heat transfer.

DESIGN TUBE LENGTH REQUIREMENTS FOR OPTIMUM EFFICIENCIES

The dimensions in the table listed below are basic guidelines used in the design of the *Reflect-O-Ray® Oil Fired OIL FIRED EDS 3.5* systems. Every effort should be made to hold the dimensions given on the layout drawing. The factory should verify any deviations from the layout drawing or for alternate and/or customized layouts.

Burner Type	0500.R 125,000 Btu/hr		0510.R 105,000 BTU/HR		0520.R 70,000 Btu/hr	
	Standard Output System – Radiant Tube Between Any Burner & Vacuum Exhauster	90'	70'	80'	60'	70'
High Output (Reduced Tube Length) Systems	80'	60'	70'	40'	60'	40'
Maximum Flows Through One Radiant Tube	2		3		4	
Minimum Distance Before Elbow	30'		25'		20'	
Minimum Distance Before Tee	40'		40'		30'	
Minimum Distance Before Damper	30'		30'		30'	

* - Distances used with 0304.INSL radiant tube assemblies.

VACUUM EXHAUSTER SELECTION

Recommended Maximum Number of Burners Per Vacuum Exhauster

Note: The factory must be consulted for any deviations to the basic design criteria listed below. Burner inputs may be mixed with each system (vacuum exhauster).

BURNER ASSEMBLIES

Vacuum Exhauster	0500.R	0510.R	0520.R
0402.WO/DI	4	4	6
0401.WO/DI	3	4	4
0201.WO	2	2	2

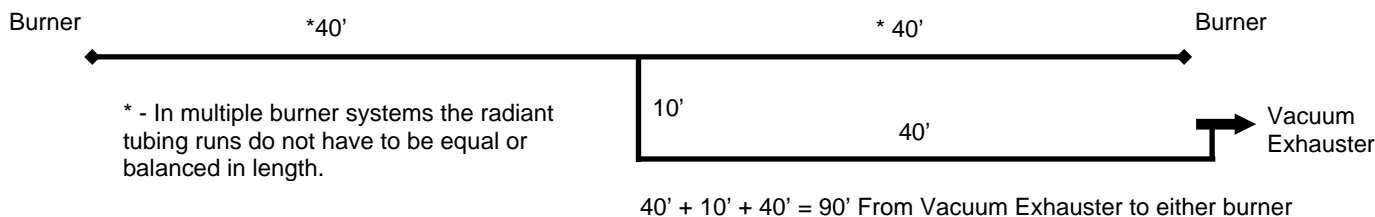

CLEARANCE TO COMBUSTIBLES

! WARNING



FIRE AND EXPLOSION HAZARD

Placement of explosive objects, flammable objects, liquids and vapors close to the heater may result in death, serious injury, fire and/or explosion or property damage. Do not store or use explosive objects, liquids and vapor in the vicinity the heater.

In all situations the clearance to combustibles must be maintained. Failure to observe clearances to combustibles will result in death, serious injury, or property damage. In storage areas where stacking of materials may occur, the installer must provide signs, which specify the maximum stacking height so as to maintain the required clearance to combustibles. Minimum clearances must be maintained from vehicles parked, below the heater. Ensure that adequate

clearance is maintained where vehicles are in operation or being serviced. Consideration must be given when running the radiant tube next to wood, paper, storage racks, hoists, building construction, etc. For building personnel safety, it is recommended that the system not be mounted lower than 9' from the floor unless fitted with protective screens. The following illustrations and information give minimum acceptable clearance to combustibles.

Minimum clearances to combustibles must be maintained for wall, floor, ceiling temperatures. **The stated clearance to combustibles represents a surface temperature of 90°F (32°C) above room temperature. Building materials with a low heat tolerance (such as plastics, vinyl siding, canvas, tri-ply, etc.) may be subject to degradation at lower temperatures. It is the installer's responsibility to assure that adjacent materials are protected from degradation.**

Clearances must also be maintained from vehicles parked below as well as storage racks, partitions, hoists, building construction, etc

In storage areas where stacking of materials may occur, the installer must provide signs that specify the maximum stacking height so as to maintain the required clearance to combustibles.

0360.00 or 0360.02 Reflector- HORIZONTAL MOUNT

	MODEL	A	B	B1*	C	D
	0500.R	7"	60"	30"	36"	36"
	0510.R	6"	60"	30"	36"	36"
	0520.R	6"	60"	30"	36"	36"

* B1 – Bottom Clearance when P/N 0304.INSUL.25 radiant tube is used
 "B" Clearances (bottom) can be reduced to 15", 25' downstream of burner

0360.00 or 0360.02 Reflector - 30° MOUNT

	MODEL	A	B	B1*	C	D
	0500.R	7"	60"	30"	36"	36"
	0510.R	6"	60"	30"	36"	36"
	0520.R	6"	60"	30"	36"	36"

* B1 – Bottom Clearance when P/N 0304.INSUL.25 radiant tube is used
 "B" Clearances (bottom) can be reduced to 15", 25' downstream of burner

0812.00 or 0812.SS Reflector - HORIZONTAL MOUNT

	MODEL	A	B	B1*	C	D
	0500.R	7"	72"	25"	30"	30"
	0510.R	6"	72"	25"	30"	30"
	0520.R	6"	72"	25"	30"	30"
<p>* B1 – Bottom Clearance when P/N 0304.INSUL.25 radiant tube is used "B" Clearances (bottom) can be reduced to 15", 25' downstream of burner</p>						

0812.00 or 0812.SS Reflector – 30° MOUNT

	MODEL	A	B	B1*	C	D
	0500.R	7"	72"	25"	30"	30"
	0510.R	6"	72"	25"	30"	30"
	0520.R	6"	72"	25"	30"	30"
<p>* B1 – Bottom Clearance when P/N 0304.INSUL.25 radiant tube is used "B" Clearances (bottom) can be reduced to 15", 25' downstream of burner</p>						

0363.00 or 0363.02 Reflector - HORIZONTAL MOUNT

	MODEL	A	B	C	D
	0500.R	7"	72"	42"	42"
	0510.R	6"	72"	30"	56"
	0520.R	6"	72"	30"	56"
<p>0500.R - "B" Clearances (bottom) can be reduced to 40", 20' downstream of burner 0510.R - "B" Clearances (bottom) can be reduced to 40", 20' downstream of burner 0520.R - "B" Clearances (bottom) can be reduced to 24", 20' downstream of burner</p>					

0363.00 or 0363.02 Reflector – 30° MOUNT

	MODEL	A	B	C	D
	0500.R	7"	72"	42"	42"
	0510.R	6"	72"	30"	56"
	0520.R	6"	72"	30"	56"
<p>0500.R - "B" Clearances (bottom) can be reduced to 40", 20' downstream of burner 0510.R - "B" Clearances (bottom) can be reduced to 40", 20' downstream of burner 0520.R - "B" Clearances (bottom) can be reduced to 24", 20' downstream of burner</p>					

INVERTED REFLECTOR

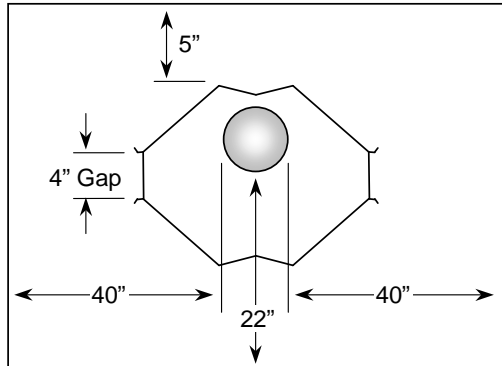

0360.00 or 0360.02 Reflector
With an Inverted 0360.00 or
0360.02 Reflector.

- Applies To All Inputs -

"U" BEND END CLEARANCE

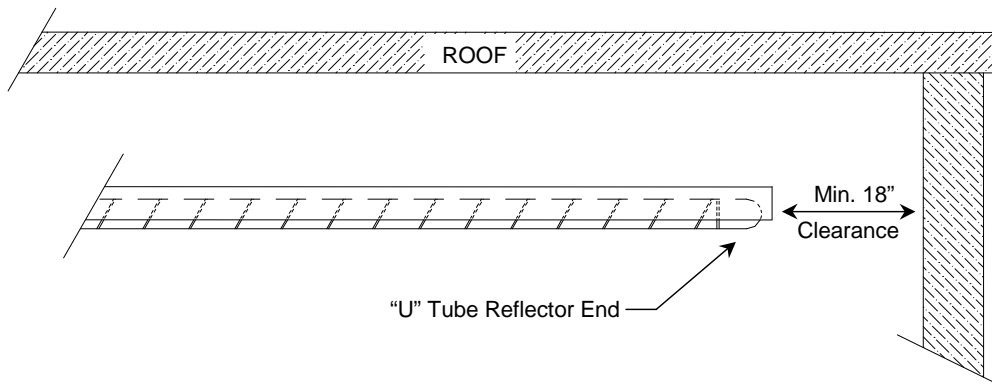

SYSTEM INSTALLATION

! WARNING

COLLAPSE, FIRE AND EXPLOSION HAZARD

Improper suspension of the tube heater may result in collapse and being crushed. Always suspend from a permanent and secure part of the building structure that can evenly support the total force and weight of entire the heating system.

Failure to suspend properly and maintain minimum clearance to combustibles may result in death, serious injury, fire and/or explosion or property damage. Always maintain minimum clearances and post clearance signs where needed.

Combustion Research Corporation recommends that *Reflect-O-Ray® Oil Fired OIL FIRED EDS 3.5* systems are hung by means of chain. **DO NOT STRETCH OR INSTALL CHAIN OTHER THAN IN A VERTICAL FASHION WHEN INITIALLY INSTALLED (BURNER NOT FIRING).**

! WARNING

DO NOT SUSPEND VACUUM EXHAUSTER BY CHAIN - USE THREADED ROD, ANGLE IRON, ETC.

If chain is not supplied by Combustion Research Corporation, furnish a chain with a minimum 90 lb. workload (trade size #3 or larger) for suspension of radiant tube and reflectors. Use 3/0 (minimum work load of 300 lbs) double loop chain to suspend the burner assembly.

CAUTION: This infrared tube system will expand and contract upon each call for heat and allowances must be made to accommodate this expansion.

Provisions must be made to limit lateral movement when systems are installed in site conditions where open doors may create a wind condition. See page 12 for details.

SUSPENSION COMPONENTS - Sub Assembly and Installation

1. Using the system layout, beginning at the vacuum exhaustor position, determine location of suspension points of system in relation to building structure, paying close attention to dimensional limits as shown on page 3.
2. Determine suspension requirements for chain, wire rope, beam clamps, etc. with the type of mounting hardware as illustrated. Secure appropriate of each item before starting installation. Suspension hardware may not be furnished with this system.
3. If any suspension supports are to be anchored in cement, drill and insert Acherman-Johnson stud anchors

(or equivalent) as required. DO NOT install anchors in existing cracks or joints.

4. Determine suspension chain lengths and proceed to cut and pre assemble suspension components.

NOTE: Each *Reflect-O-Ray® OIL FIRED EDS 3.5* burner assembly is equipped with a suspension point. Adjust as required to keep the burner assembly level and square to the radiant tubing.

5. Install beam clamps, eyebolts, etc. at predetermined suspension locations - refer to the installation layout and the illustration on page 11 of this manual for guidance.

IMPORTANT NOTE: If wind or sever air movement can be encountered in the building (such as found in airplane hangers where opposing doors are simultaneously open) or if your area is prone to seismic activity, additional support of the radiant tube and reflector network will be required. See page 12 for details

RADIANT TUBE INSTALLATION

The *Reflect-O-Ray® OIL FIRED EDS 3.5* radiant heating system is sealed system. Therefore the heat radiant tubing installation must be adhered to as outlined in this manual for optimum performance as designed.

RECOMMENDED HANGER LOCATIONS

For standard systems, the first hanger should be located approximately 5" from the burner and the next two combination hangers shall be hung on approximately 56" centers. The rest of the system combination hangers may be hung on approximately 9'-10" centers with intermediate reflector supports placed halfway between hangers.

For systems using 0304.INSL tubes , the first hanger should be located approximately 5" from the burner and the next five (5) combination hangers shall be hung on approximately 56" centers. The rest of the system combination hangers may be hung on approximately 9'-10" centers with intermediate reflector supports placed halfway between hangers

NOTE – THE WELD SEAM ON THIS FIRST (AND SECOND IF PROVIDED) SECTION OF TUBE MUST BE POSITIONED SO THAT IT IS ON THE BOTTOM OF THE TUBE WHEN INSTALLED.

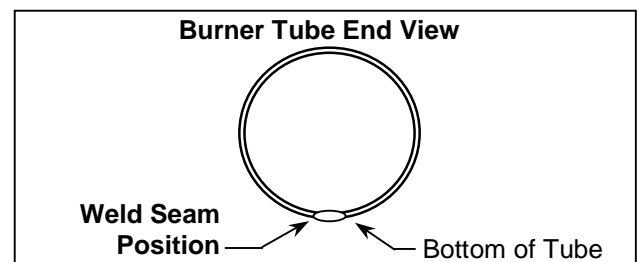

Each reflector should be supported at two points, either with two combination hangers or with one combination hanger and an intermediate support

NOTE: When a vertical rise of tube is necessary, use a combination hanger (P/N 0361.00) at both the lower horizontal run hanger and at the upper horizontal run. If the vertical run exceeds ten feet (10') a midway support must be installed. This support may be secured to a wall, beam or fabricated support. It is recommended that the vertical run not exceed twenty-five feet (25').

Radiant Tube Sub-Assembly:

⚠ CAUTION

CUT HAZARD - SHARP EDGES.



Wear protective gloves when installing and handling and cutting radiant tubes. Failure to follow these instructions will result in personal injury.

If it is recommended that a maximum of twenty-foot lengths of radiant tube and possibly an elbow be assembled on the floor before raising into position.

Experience has shown that it is best to start laying out the system from the exhauster end, although this is not a requirement. Avoid small segments that cannot be supported properly according to the instructions in this manual.

1. Apply sealer sparingly from the tube furnished to the outside of the heat tube coupler, elbows, and other fittings.

NOTE: Failure to use sealer can result in loss of vacuum.

Apply sealer sparingly to outside of coupler

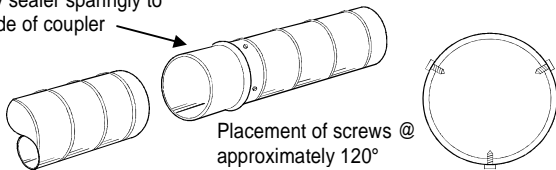

2. Secure joint with sheet metal screws to provide a mechanical joint rather than rely on friction. Use damp cloth to remove excess sealer. Heat tube and fitting assembly ends are designed for minimum clearance and tight fitting to minimize air infiltration.

3. Insert coupler inside tube section. Be sure the radiant tube is butted up tightly against the stop rim in the middle of the coupler. Note: Tolerances are closely controlled at this point to insure as tight a joint as possible. At this point make sure that radiant tube sections to be joined are straight and in line.
4. Attach combination hanger (0361.00) to the radiant tube at dimensional support locations as outlined in this manual. Combination hangers should be positioned so that The locking loop / 45° suspension point, face the same direction. Combination hanger's (0361.00) shall be positioned at all elbows and tee's so as to provide support for the adjoining reflector.
5. Position the intermediate reflector supports (0362.00) between the combination hangers illustrated below.
6. Using two or more men, raise the length of pre assembled tube sections up to suspension height, and using "S" hooks or turnbuckles attach tube hangers to suspension hardware.
7. Check to be sure all suspension hardware, chain, wire rope, etc., is hanging straight. Reposition hangers where necessary until suspension is straight.
8. Adjust suspension length until heat tube is straight and in line. If possible, heat tube should be parallel with floor.
9. Proceed in manner described above to complete hanging the remainder of the radiant tubes as described and detailed in this owner's manual and the layout drawing.

NOTE: Review system layout carefully before any cutting radiant tube. If cuts are not made where shown, radiant tube lengths may be short and require additional tube couplers to complete the project.

When cutting radiant tubes, de-burr them with a file to remove sharp edges and facilitate easier assembly with the couplers.

10. Make final check to be sure heat tube is straight and in line before installing reflectors as illustrated on pages 13 - 15.

HANGER & SUPPORT LOCATIONS – STANDARD INSTALLATION

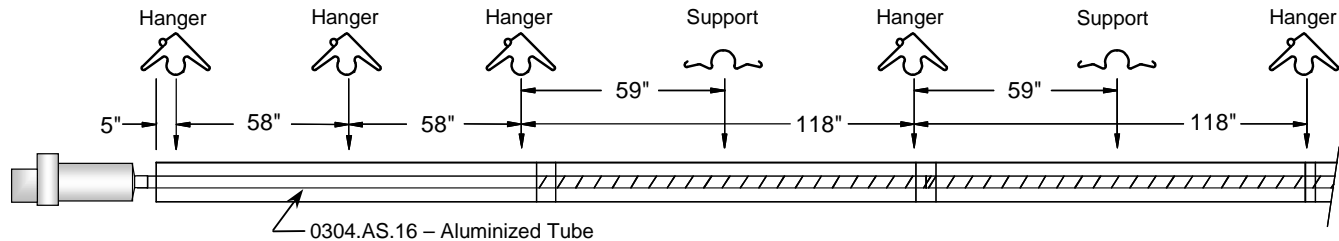

HANGER & SUPPORT LOCATIONS – “INSL” TUBE SYSTEM

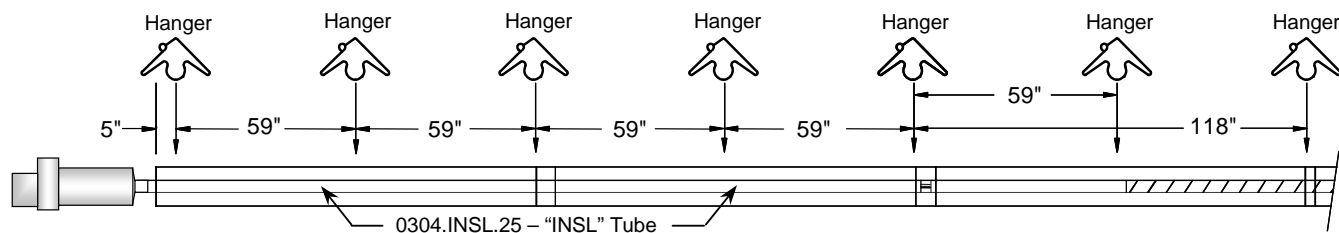

COMBUSTION TUBE INSTALLATION

The first section or radiant tube downstream of the burner is a heavy wall 16 Ga. aluminized steel tube. This tube is referred to as the combustion tube. One end of this tube is swaged to fit inside the next spiral radiant tube. The end that is un-swaged is coupled to the burner assembly –

see page 19. It is necessary that the weld seam on this combustion tube be positioned so that it is on the bottom when installed.

This applies for both straight tube and “U” tube systems. When the systems are mounted on a 30° angle the weld seam should always be on the bottom.

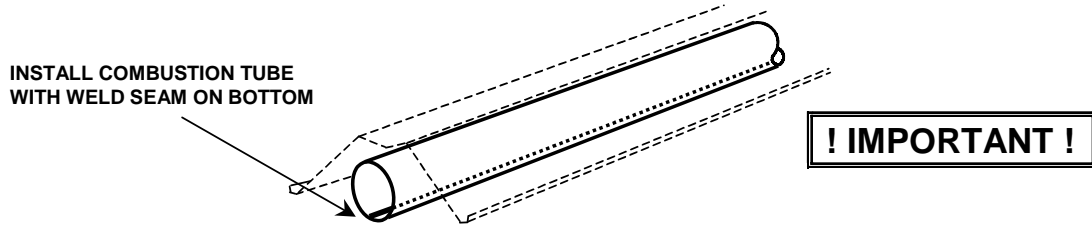

INSUL-TUBE ASSEMBLY

UNASSEMBLED COMPONENT VIEW – (TOP)

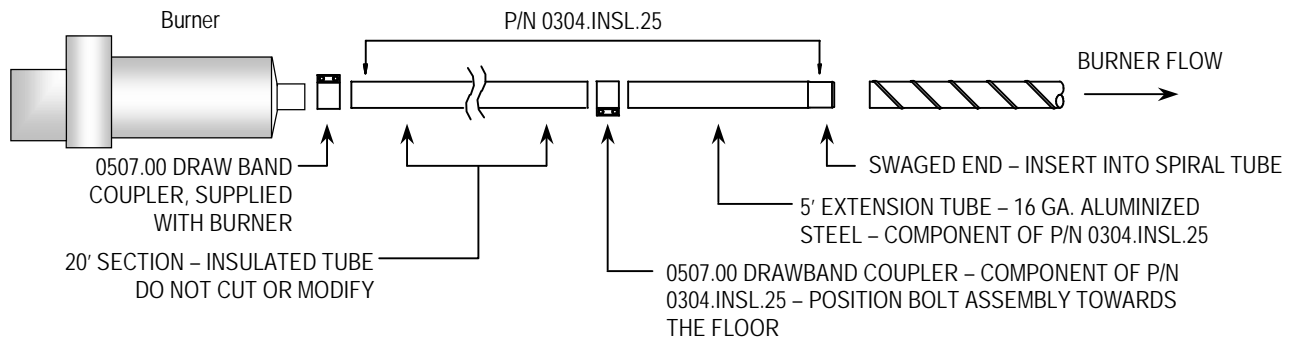

ASSEMBLED VIEW – (TOP)

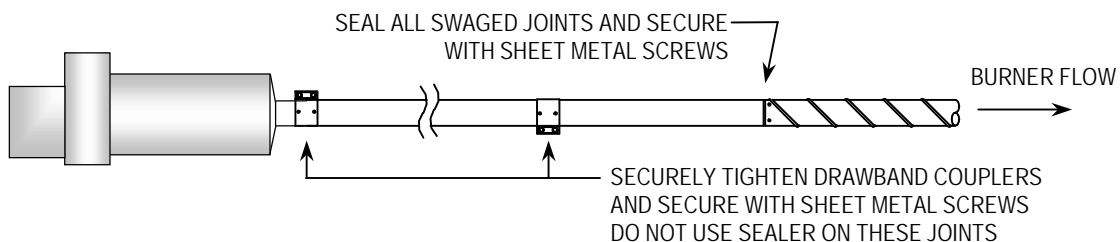

DAMPER TYPES

Damper assemblies are to be installed as per layout drawing. Each burner flow must be equipped with a damper assembly so that accurate vacuum settings can be made.

NOTE: Install damper handles on the side or bottom, position locating holes so that they face, or rotate downward. The damper handle can be rotated by removing the two nuts, which hold the blade, and setting plate in place. Rotate 180° and reassemble - take care so as not to "strip out" handle. When turning the damper handle, the center-retaining spud on the opposite side should rotate simultaneously.

0341.00 DAMPER ASSEMBLY

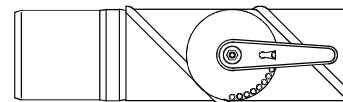

Install Handle On Side Or Bottom Of Tube
(Position locating holes as shown)

NOTE: 0341.00 damper assembly for use with single burner systems and when DAMPER TEE'S are not practical.

0307.AS.B - Damper TEE

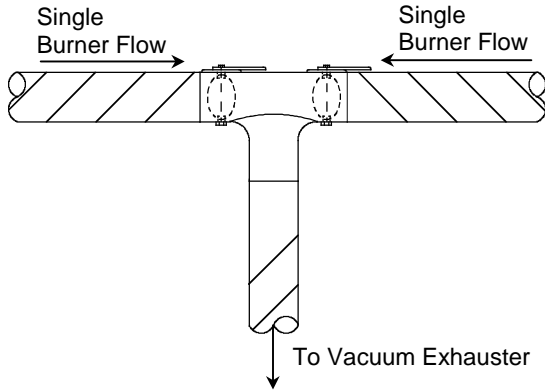

0307.AS.C - Damper

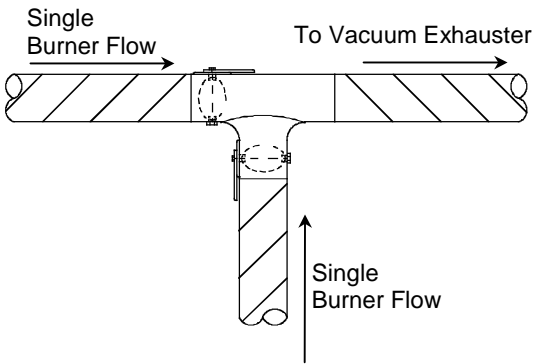

0307.AS.XB - "X" Fitting With Dampers

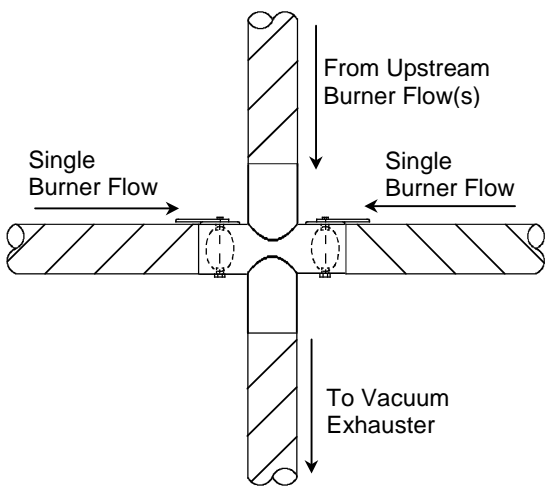

0307.AS.XC - "X" Fitting With Dampers

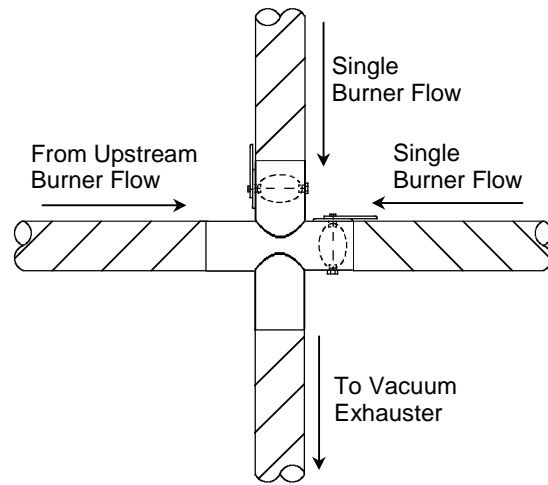

SUSPENSION METHODS

! WARNING

COLLAPSE, FIRE AND EXPLOSION HAZARD



Improper suspension of the tube heater may result in collapse and being crushed. Always suspend from a permanent and secure part of the building structure that can evenly support the total force and weight of entire the heating system.

Failure to suspend properly and maintain minimum clearance to combustibles may result in death, serious injury, fire and/or explosion or property damage. Always maintain minimum clearances and post clearance signs where needed.

Radiant tube and reflector system shall be suspended by chain (trade size #3 or larger), wire rope, etc., minimum workload of 90 Lbs. All suspension hardware must be corrosion resistant. For fine adjustment turnbuckles may be used.

NOTES:

SUSPEND IN VERTICAL FASHION WHEN INITIALLY INSTALLED (BURNER NOT FIRING).

Suspend the burner assembly with 3/0 closed loop chain or greater – minimum working load of 300 lbs. Radiant tube and reflector system is to be suspended with trade size #3 chain or heavier – working load of 90 lbs. minimum. A minimum of 12" (30 cm) of hanging chain is recommended. This allows for system expansion and contraction, reducing the likelihood of reflector and radiant tube warping and/or expansion noise.

CAUTION: Infrared tube systems expand and contract upon each call for heat. System expansion of up to 3" can be expected.

Provisions must be made to limit lateral movement when systems are installed in site conditions where open doors may create a wind condition – see page 12 for guidelines.

Radiant tubes **DO NOT** require sloping.

For fine adjustment turnbuckles may be used.

NOTES:

- SECURE TURNBUCKLES SO THAT THEY WILL NOT UNWIND OR UN-SCREW.
- CRIMP "S" HOOKS CLOSED BEFORE LEAVING JOB. REFLECTORS ARE NOT TO BE INSTALLED ON TOP OF COMBINATION HANGERS.

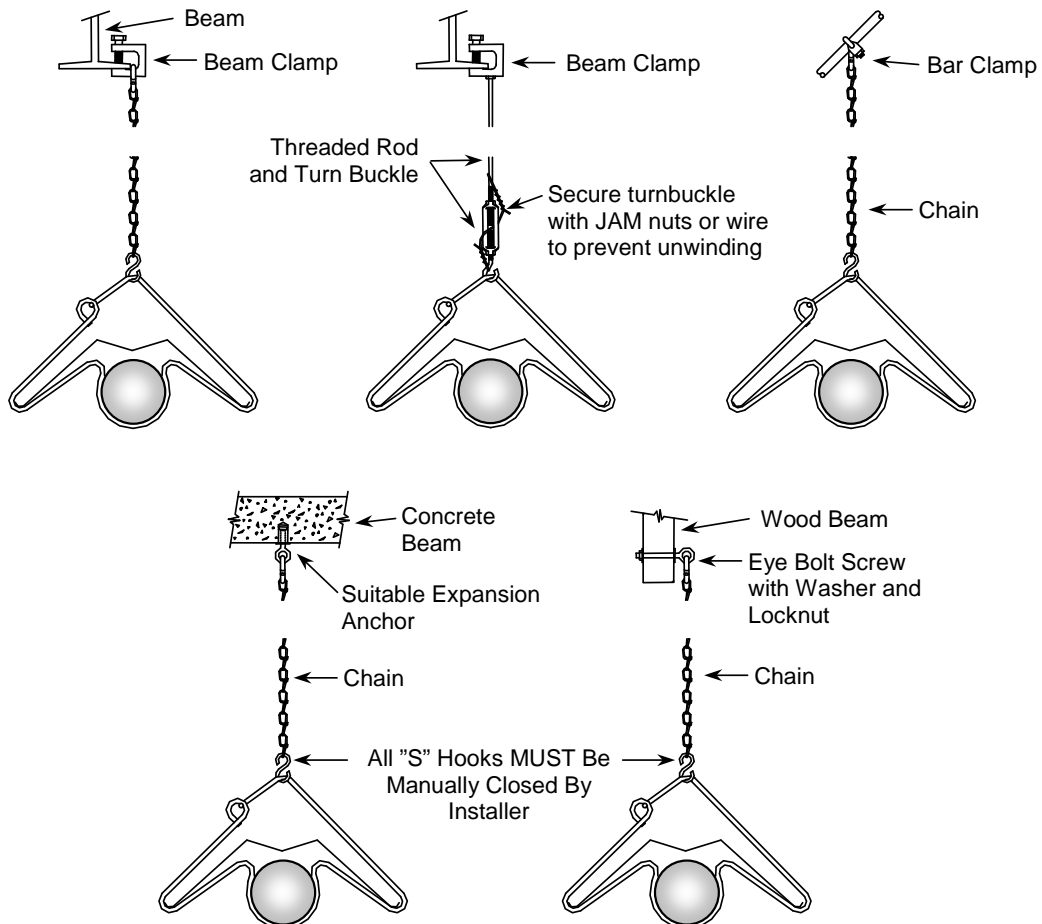

SEISMIC RESTRIANT SUSPENSION METHODS

For standard seismic restraint such as earthquake prone areas, install seismic restraint chain or cable as shown below. If high winds can be encountered in the building, such as found in airplane hangers where opposing doors are simultaneously open, or system is installed near or below the door opening, additional support of the radiant

tube and reflector network will be required. See the "Seismic Suspension For High Wind Applications" below for details. If there are any questions regarding what method is best suited for your application consult your sales representative or contact the factory. If the system is a straight system (no elbows or tee's), apply an anti sway chain or wire rope which is parallel to the radiant tube at approximately the middle of the run.

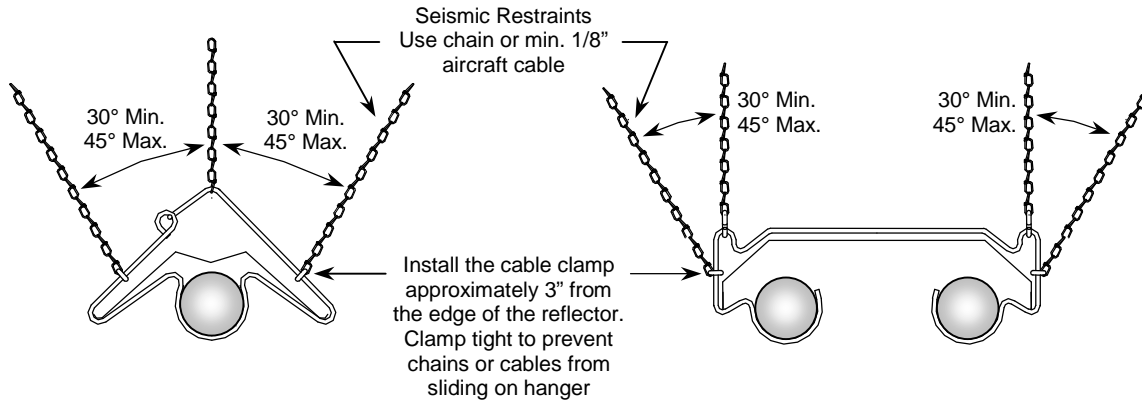

SEISMIC RESTRAINT FOR HIGH WIND APPLICATIONS

In high wind conditions it is recommended that seismic restraints and reflector retention wire be installed. See details below for recommended installation of seismic restraint and anti sway retention chains (wire rope). The vertical threaded rod shall be attached and suspend the reflector hangers at intervals of eight to ten feet (8' - 10'). At least one vertical threaded rod shall be placed at every elbow and/or tee connection. The threaded

rod is used to prevent the system from lifting during high wind conditions, the chain or wire rope will keep the system from swaying from side to side. When connecting threaded rod to "Z" purlin use beam clamp or drill a hole through "Z" purlin and secure with two 3/8" nuts and a lock washer. If the system is a straight system (no elbows or tee's), apply an anti sway chain or wire rope which is parallel to the radiant tube at approximately the middle of the run.

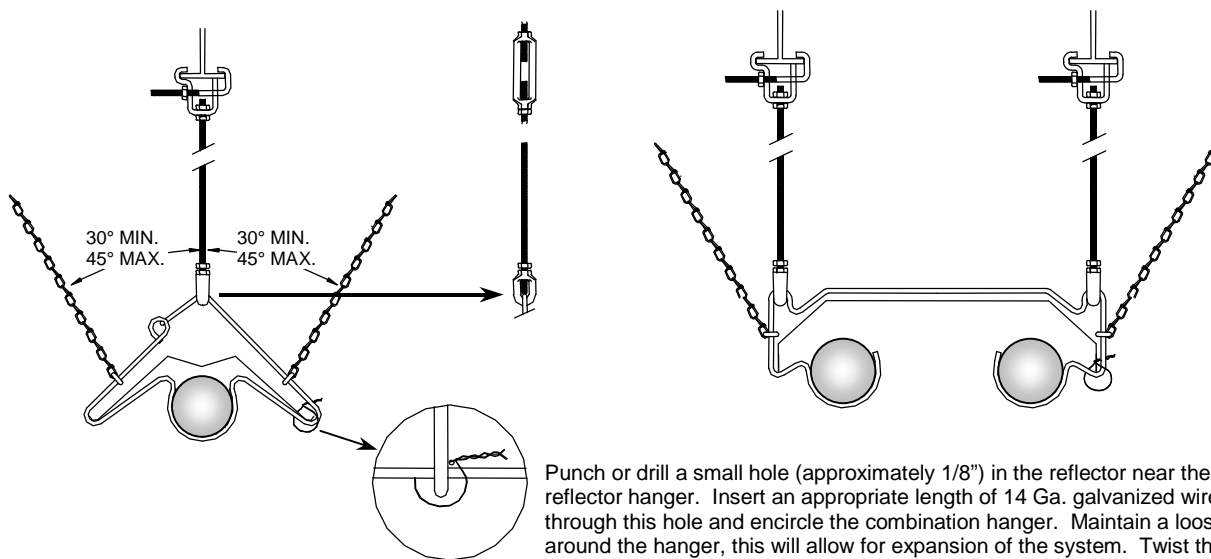

REFLECTOR INSTALLATION

⚠ CAUTION

CUT HAZARD - SHARP EDGES.



Wear protective gloves when installing and handling and cutting reflectors. Failure to follow these instructions will result in personal injury.

Radiant heat tube combination hangers are an integral part of the reflector support system. Improperly installed radiant tube hangers will distort reflectors and result in an undesirable appearance of the entire system, and can lead to vibration and noise.

Check to be sure all combination hangers and intermediate supports are hanging straight. Tubes must be straight and in line before installing reflectors.

Install reflector elbows and "tees" where required.

1. Starting from burner slide reflector through tube hanger until end stops against drawband coupler. Nearest the burner, attach reflector end cap with 4 sheet metal screws.
2. Adjust position of reflector supports so that reflector is held level and parallel with heat tube. Where possible, position one support at overlapped ends of reflectors.
3. Using same procedure, continue to install reflector sections until entire system is complete. Make sure each reflector section is overlapped a minimum of 1 -2" and secured as outlined on this page.
4. When last section of reflector has been installed, inspect heat tube and reflector assembly as follows:
 - a. Check to be sure all heat tubes are straight and in line. Adjust suspension when necessary.
 - b. Make sure all radiant tube joints are properly aligned, sealed, and secured.
 - c. Check all heat tube suspension points, clamps, turnbuckles, lock nuts, etc. are in place and tight. All suspension chain should be hanging straight down.
 - d. Check all reflector joints for minimum 1 - 2" overlap.
 - e. Overlapped joints are secured with sheet metal screws. Make sure expansion joint is in every straight run - see the following expansion joint illustration.
 - f. Check all reflector hangers and supports for location and make sure reflectors are straight and in line.
 - g. Make sure all combination hanger hooks are closed.

TYPICAL REFLECTOR LAYOUT WITH EXPANSION JOINTS

An expansion joint consists of a reflector overlap without being secured together. This allows for freedom of movement during heat up and cool down. Expansion joints are to be placed at approximately the center of each straight run of reflectors with a maximum of three (3) reflectors connected together. Additional expansion joints in each straight run may be necessary.

All other reflector joints, reflector elbows and reflector tee's should be overlapped 1 - 2" and sheet metal screwed together, DO NOT position an expansion joint at an elbow or tee.

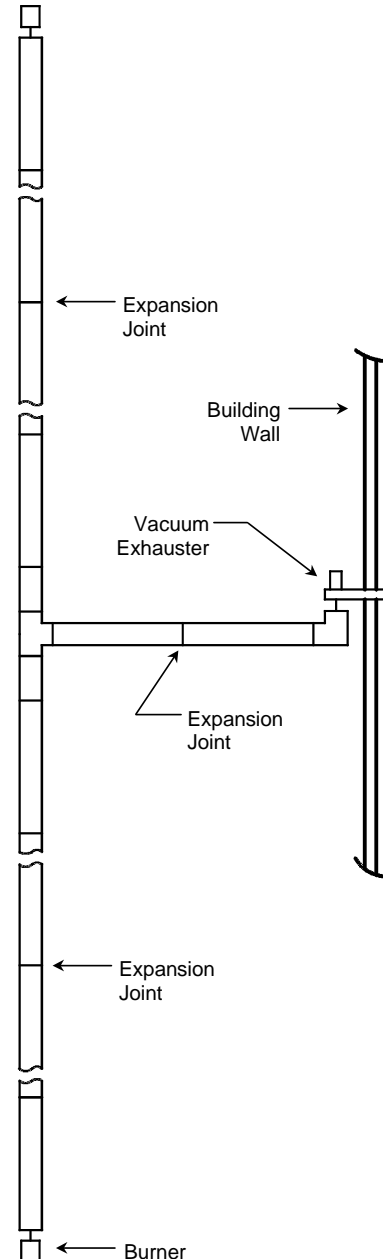

TUBE & REFLECTOR HANGING METHODS

The *Reflect-O-Ray*® System reflectors can be suspended horizontally or at a 30° angle. The combination hanger is designed so that the reflector angle will be horizontal when

Horizontal Mounting With
"Combination" Hanger

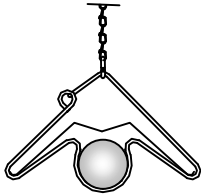

30° Mounting With
"Combination" Hanger

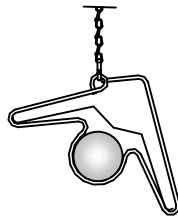

Horizontal Mounting With
"Panel" Hanger

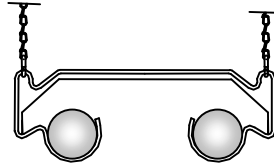

30° Mounting With "Panel"
Hanger

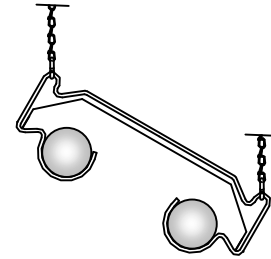

suspended from the top loop or at a 30° angle when suspended from the offset loop – see the illustration below. The panel hangers may also be suspended horizontally or at a 30° angle – see illustration below.

PERIMETER MOUNTING

In areas of high heat loss such as doorways and the perimeter of some buildings, it may be desirable to install the reflectors so that heat is concentrated and directed to a specific area rather than straight down. Two options are available to accomplish this, 1) angle mount the reflector as shown above or 2) install side shields.

SIDE SHIELD INSTALLATION

Optional side shield reflectors may be installed on either side or both sides of the reflector. The 10-ft. (3 m) long side shields should line up with a reflector and have identical overlap and expansion joints.

1. Position the side shield reflector next to the reflector, and mark the areas where relief notches must be cut.
2. Cut the appropriate relief notches as noted.
3. Secure the side shield to the reflector with #8 x 3/8" sheet metal screws. The screws should be used approximately every 24" (61 cm).
4. Install the side shield supports every five feet (5')
5. An expansion joint must be used in each straight run. This expansion joint should match the location of the expansion joint for the reflectors. All overlap areas should also match the reflector overlap.

In applications where excessive air movement is encountered, such as open doors and the like, the Side Shields should be fastened together with 2 sheet metal screws or pop rivets at each overlap joint. **NOTE: DO NOT** screw the expansion joints together.

0360.00 REFLECTOR & 0367.00 SIDE SHIELD

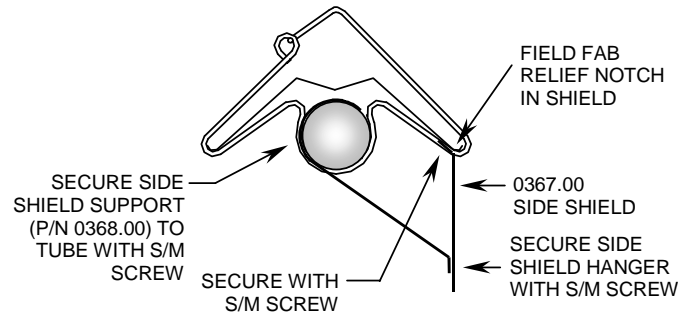

0812.00 REFLECTOR & 0367.00 SIDE SHIELD

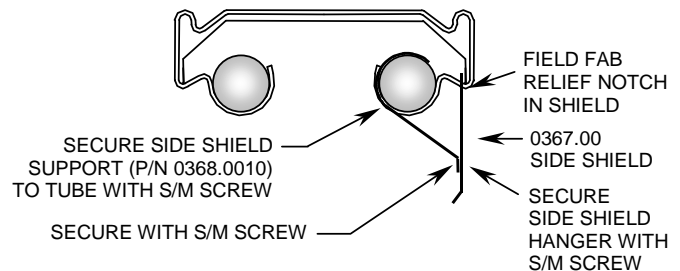

0363.00 REFLECTOR & 0366.00 SIDE SHIELD

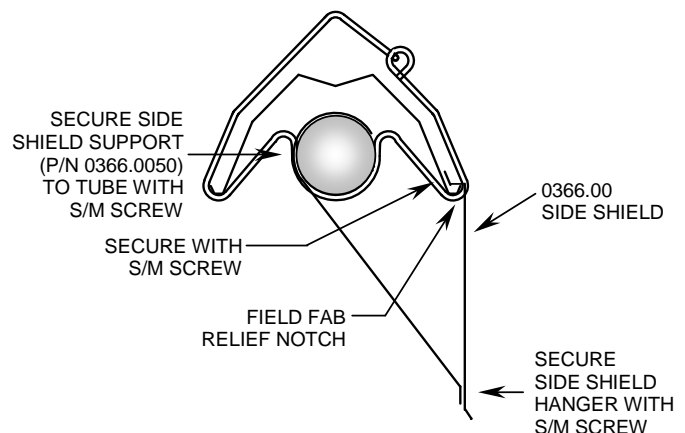

REFLECTOR ELBOW CONNECTION

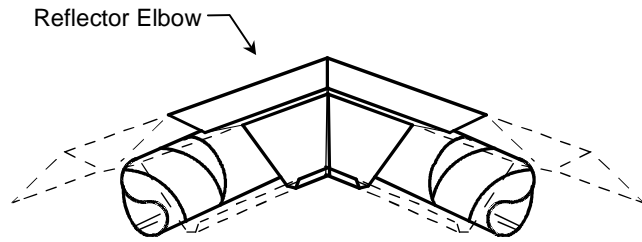

Secure To Connecting Reflector
With Sheet Metal Screws

REFLECTOR TEE CONNECTION

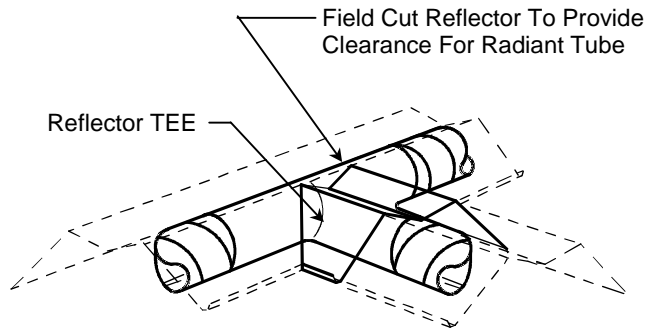

Use Sheet Metal Screws To Secure
"Tee" In Place

For "X" fittings (PN 0307.AS.X) use the same technique shown, cutting and another relief hole on the opposite side of the reflector and installing a second reflector tee.

DECORATIVE GRILLE INSTALLATION

⚠ CAUTION

CUT HAZARD - SHARP EDGES.



Wear protective gloves when installing and handling aluminum decorative grille and side shields. Failure to follow these instructions will result in personal injury.

When installing the heating system above a suspended ceiling, unpainted aluminum decorative grille must be used directly beneath the radiant tube system. The use of regular ceiling tiles directly beneath the radiant tube will create an unsafe condition.

The unpainted aluminum decorative grille provides an attractive finish to the system when installed over a suspended ceiling. The aluminum Decorative Grille (PN 0369.00) comes in standard 2 ft. x 4 ft. (60 cm x 120 cm) sections and is installed in place of the ceiling tile. The decorative grill should extend completely under all of the radiant tube as well as the burner assembly.

The radiant tube is suspended in normal fashion, centered over the decorative grille. The radiant tube must be installed, as shown below, with a minimum distance from the radiant tube to the decorative grille of 6" (15.2 cm) to a maximum of 10" (25.4 cm).

"T" bar heat shields (PN 0369.21) must be installed over ceiling "T" frame members that pass underneath the radiant tube. The Decorative Grille Side Shield reflector (PN 0369.11) is available in 10-ft. (3 m) lengths. Lay the side shield along the standard reflector and cut suitable notches for the reflector hangers and "T" bar sections. As sharp edges can be encountered when working the aluminum decorative grille and side shields, gloves should be worn.

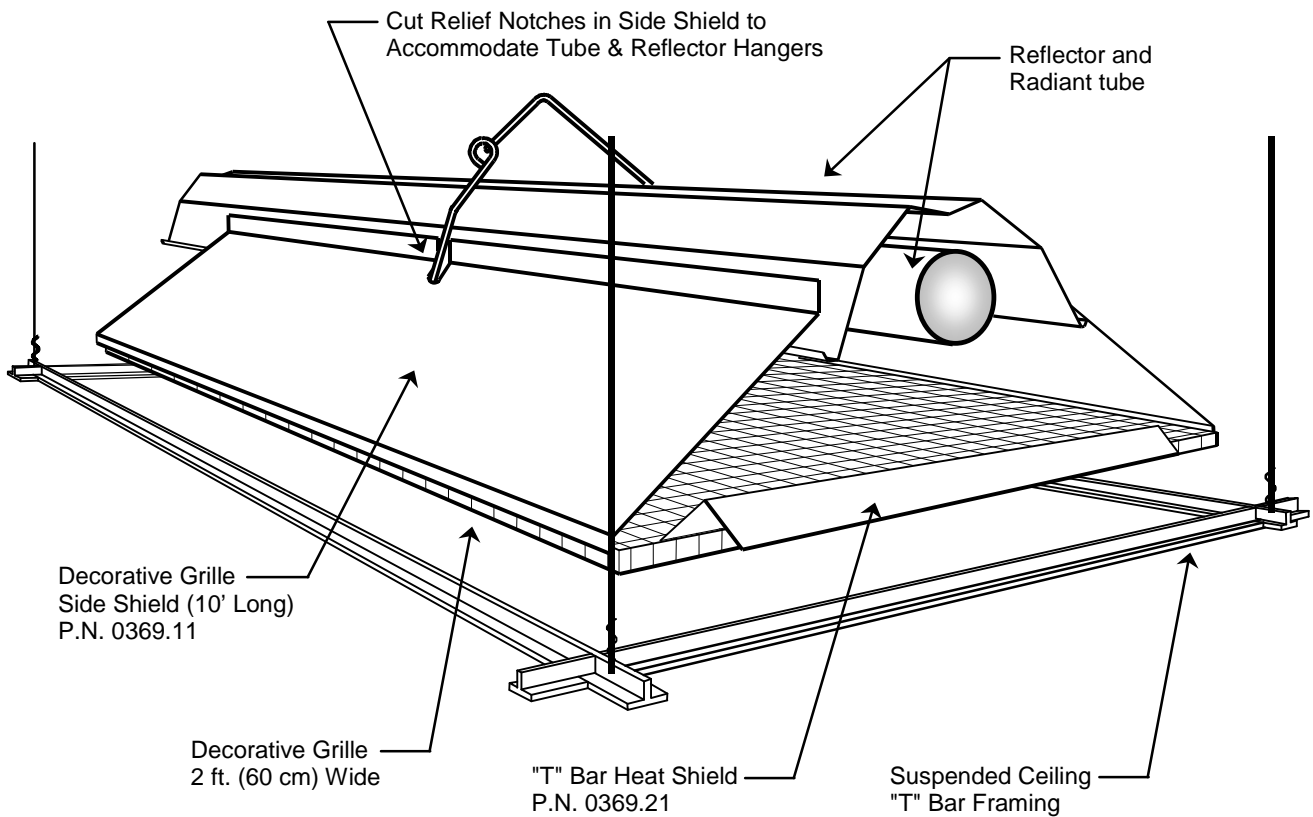

WALL PENETRATIONS

⚠ WARNING

FIRE HAZARD



IMPROPER INSTALLATION CAN CAUSE DEATH, SEVERE INJURY AND/OR PROPERTY DAMAGE.

Refer to the following instructions as well as the engineering drawing for proper installation of the Reflect-O-Ray® OIL FIRED EDS 3.5 System.

INSTALLATION:

Installation must comply with local building codes, or in the absence of local code, with the National Fuel Gas Code, ANSI Z223.1- (current standard) - same as NFPA Bulletin No. 54 for the United States and the CAN/CGA B149 (current standard) for Canada.

1. The wall penetration must be a minimum of 25' downstream of the burner.
2. A wall thimble suitable for 6", Type "B" vent (or better) must be used.
3. Use an all-steel 6" type "B" vent duct (or better). The 6" vent assembly must extend a minimum of 18" on either side of the wall. Secure the 6" type "B" vent to the wall thimble with sheet metal screws.
4. The Reflect-O-Ray® radiant tube should be positioned so that it passes through the middle or center of the 6" type "B" vent duct.
5. The reflectors, which are fitted with end caps, shall be within one inch of the end of the 6" type "B" vent duct.

NOTE: The illustration below depicts a penetration through a non-combustible wall. For penetrations through combustible walls contact the factory for guidance.

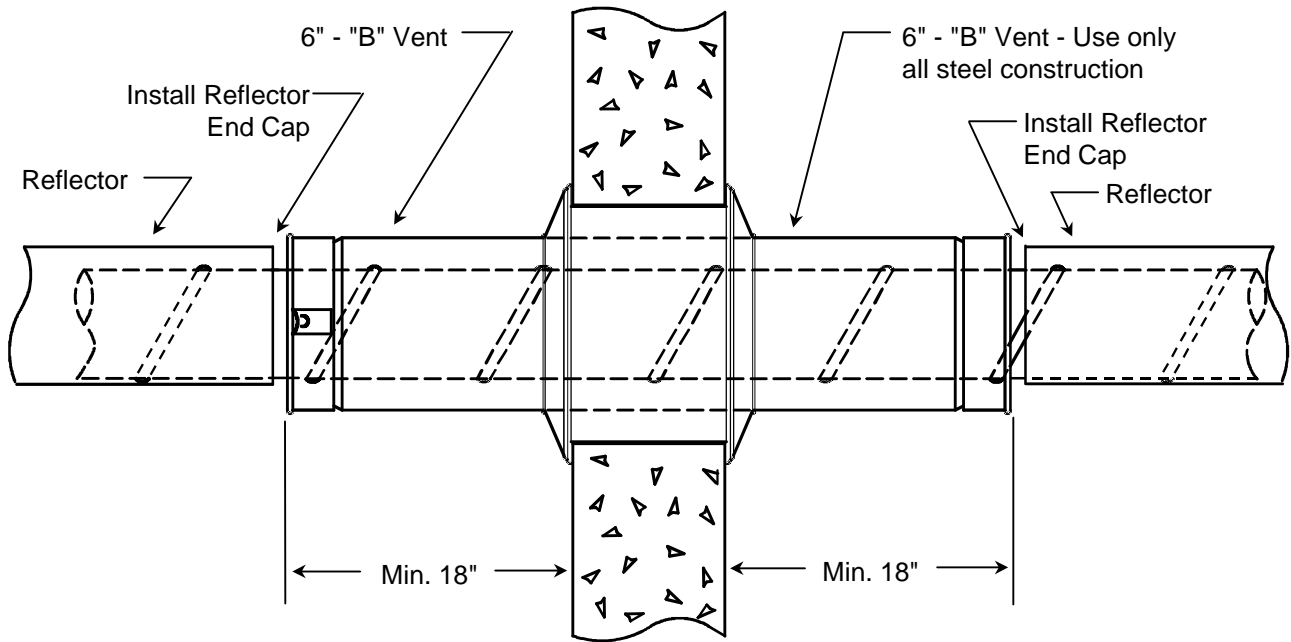

CONNECTING BURNER ASSEMBLY TO RADIANT TUBE/REFLECTOR ASSEMBLY

! WARNING

COLLAPSE, FIRE AND EXPLOSION HAZARD



Improper suspension of the tube heater may result in collapse and being crushed. Always suspend from a permanent and secure part of the building structure that can evenly support the total force and weight of entire the heating system.

The burner(s) associated with each vacuum exhauster must operate as a system. The thermostat must control both the Vacuum exhauster and burner(s). **DO NOT CONTROL SEPARATELY. Burner(s) MUST NOT be wired "HOT"**. Refer to the electrical wiring section of this manual.

Failure to maintain minimum clearance to combustibles may result in death, serious injury, fire and/or explosion or property damage. Always maintain minimum clearances and post clearance signs where needed.

1. Using 1/0 closed link chain (or heavier), hang the burner so that it butts up to the 16 Ga. tube of the tubing and reflector assembly, and connect the two with the draw band coupler provided. **DO NOT APPLY SEALER TO THIS CONNECTION.** Position bolting assembly on the top of the tube assembly as shown. After tightening the coupler, check to make sure the burner is lined up squarely. Reposition as may be required, and re-tighten the draw band clamp.
2. The coupler flange should be positioned on the **TOPSIDE** of the tube. Tighten bolts on coupler to 50 to 70 ft. lbs. Secure with 2 sheet metal screws. See illustration below.
3. Connect the oil lines as outlined.
4. If used, connect the combustion air inlet as shown on page 23.

NOTES: Heater must be independently supported and not rely on the oil supply line or electrical line for any of its support. If there is not a convenient point for suspending the hanging chain above the heater **DO NOT** try to "stretch" the span by having severe angles on the chain. Rather build a bridge between the existing building structure using angle Iron, Uni-strut, etc. and then suspend the chain so that it hangs vertically.

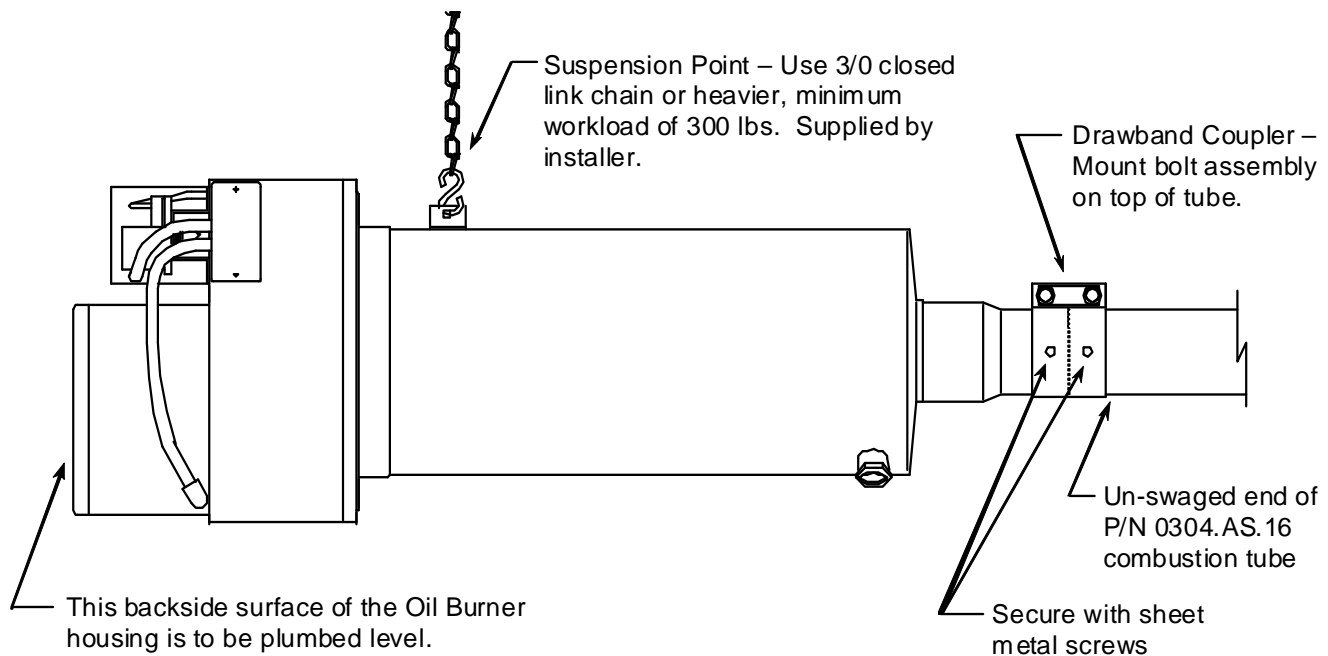

OIL SUPPLY

⚠ WARNING

FIRE OR EXPLOSION HAZARD



IMPROPER INSTALLATION, ADJUSTMENT, ALTERATION, SERVICE OR MAINTENANCE CAN CAUSE DEATH, SEVERE INJURY AND/OR PROPERTY DAMAGE.

Proper and sound installation of oil lines must be completed. Failure to do so may result in premature failure and/or oil leaks.

Installation of oil burning equipment should be made in accordance with NFPA Publication No. 31, obtainable from the National Fire Protection Association. In Canada the installation must conform to C.S.A. B139, Installation Code for Oil Burning Equipment.

It must be understood that Combustion Research Corporation cannot and does not represent that the following information for oil circuits will satisfy any particular local code requirements. Such compliance is the sole responsibility of the installing contractor.

Particular note should be given to the installation of the storage tank, piping, pump and valve installation to make sure it complies with the above publications. Installation is to be performed by a qualified licensed contractor who is familiar with liquid fuel burning systems. To insure a proper and smooth operating installation, deviations from the recommendations should be avoided. Deviations from recommended installation can result in nuisance shutdowns requiring emergency service. The following precautions should be taken:

- Do not place storage tank directly below roof overhangs
- Place tank in an area with the least direct sunlight exposure - this will reduce internal sweating in an unfilled portion of the oil tank.
- Keep tank filled as much as possible - USE ONLY #2 OIL.
- It is recommended that when bringing the #2 fuel oil into the building a minimum 3/4" line should be used. This line should be a minimum of 20' long and should be run along the inside wall which will give the oil a chance to warm up before it is pumped up to the burner supply system.
- Use a minimum 1/2" line to ceiling suspended storage (day) tank.
- Install an oil filter in the suction side of the booster pump as well as individual filters at each burner assembly.
- Proper fusible link valves and gate valves must be installed.

The following pages show two types of oil supply systems. These schematics are for guidance purposes only.

Installation must comply with all national and local codes.

TYPICAL DAY TANK INSTALLATION

The following oil supply circuit shows a day tank arrangement with the burners set up as a two pipe system. This layout has proven to be an acceptable and reliable method of oil supply. In all cases it is recommended that

the *Reflect-O-Ray® Oil Fired* burners be installed as two pipe systems.

Install suitable oil filters before the oil supply pump and secondary filters at each burner assembly. Fusible link oil valves must be installed in both the supply side (suction) and return side (discharge) of the burner pump.

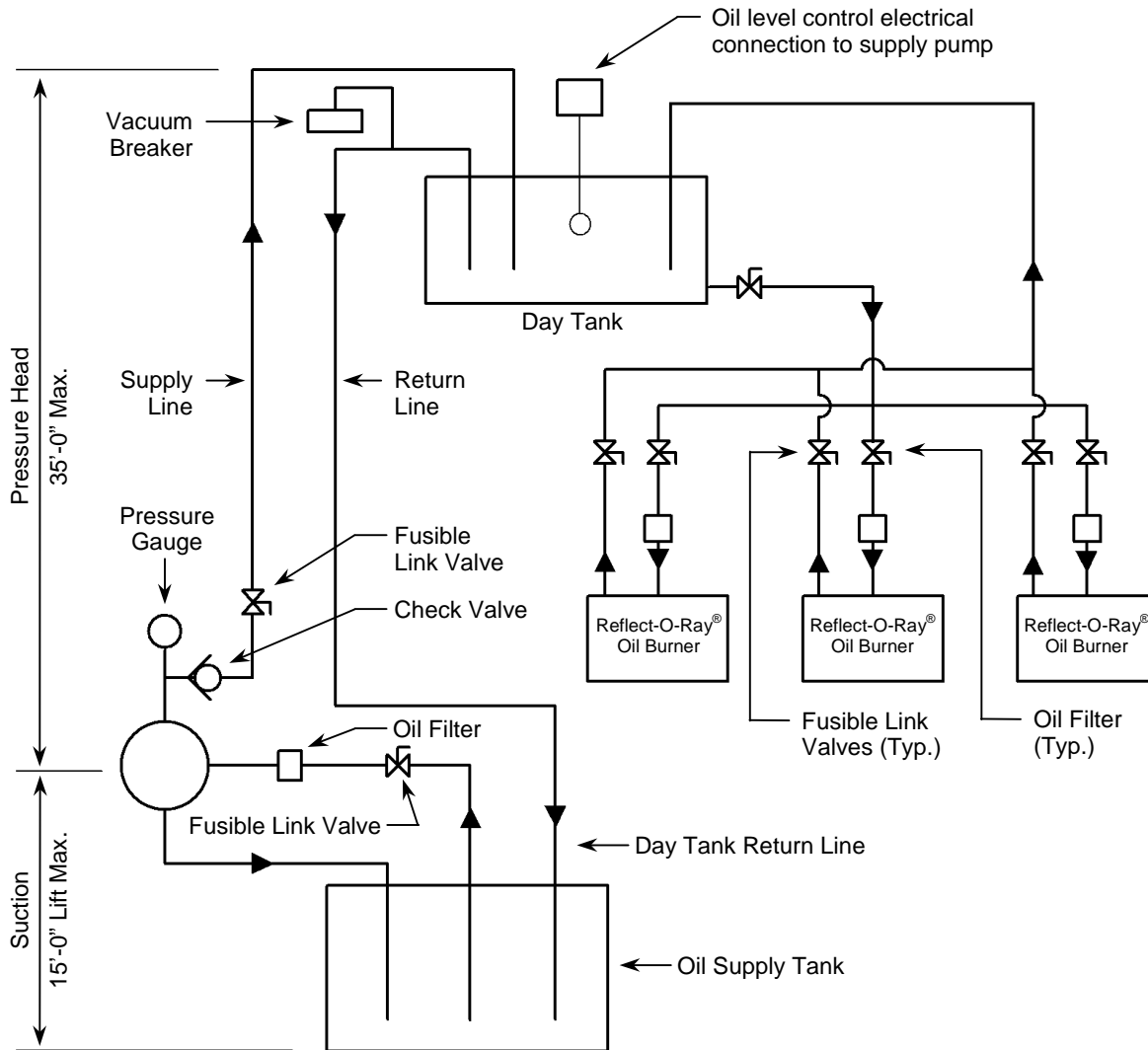

LOOP TYPE SYSTEM INSTALLATION

The following oil supply circuit shows a loop type oil supply system. The *Reflect-O-Ray® Oil Fired burners* are shipped as a two-pipe system. This layout shows a single pipe feed to the burner assembly, however an oil De-aerator device has

been installed so that the burner assemblies can operate as the recommended two pipe system. This device is marketed under the name of "Tiger Loop".

Install suitable oil filters before the oil supply pump and secondary filters at each burner assembly. Fusible link oil valves must be installed in both the supply side (suction) and return side (discharge) of the burner pump.

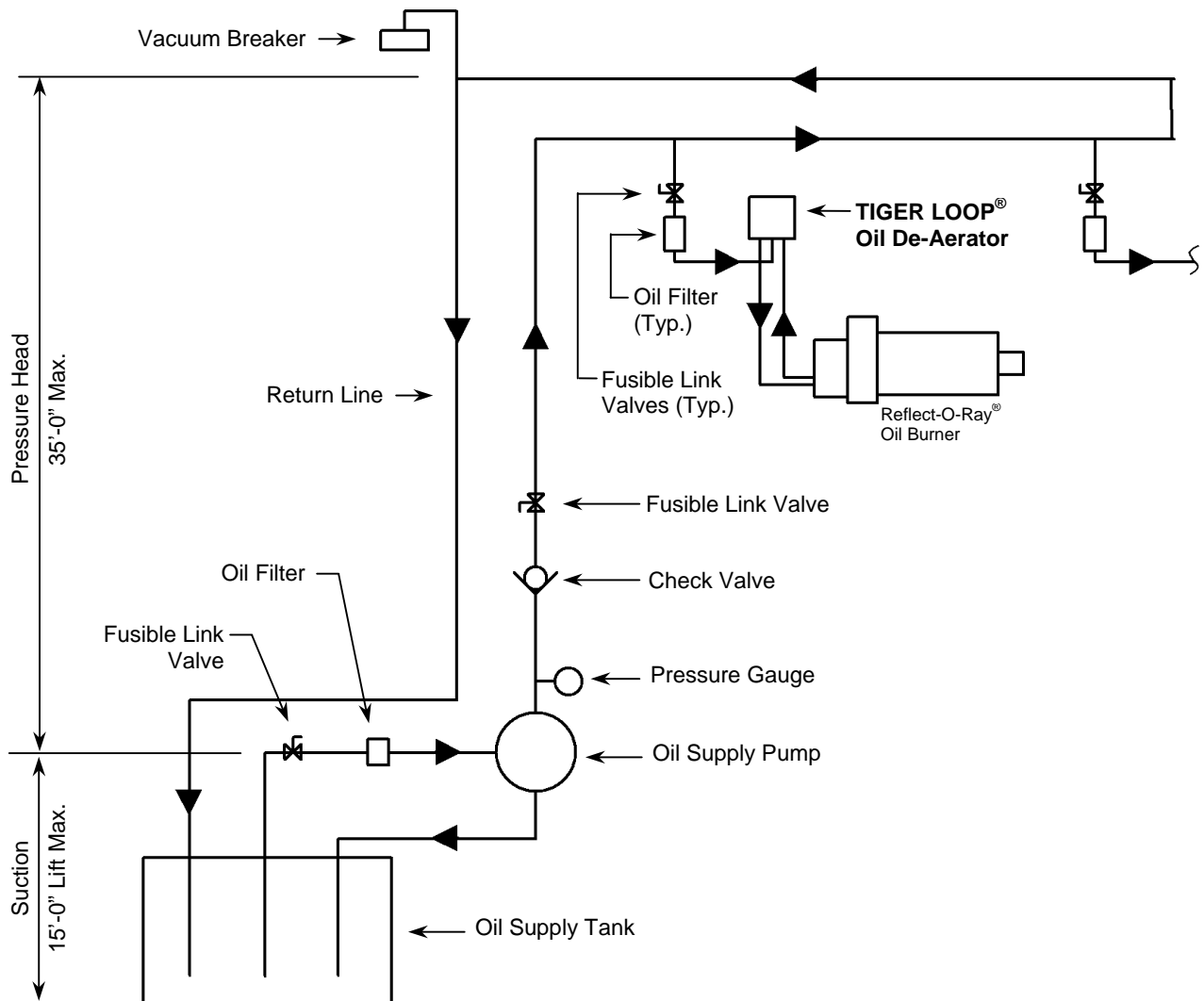

FLEXIBLE OIL CONNECTOR

⚠ WARNING

FIRE OR EXPLOSION HAZARD



IMPROPER INSTALLATION, ADJUSTMENT, ALTERATION, SERVICE OR MAINTENANCE CAN CAUSE DEATH, SEVERE INJURY AND/OR PROPERTY DAMAGE.

There is expansion of the radiant pipe with each firing cycle and this will cause the burner to move with respect to the oil supply line. This can cause an unsafe condition if the oil pipe connection is not done in strict accordance to the instructions.

Install the flexible oil hose as shown in the diagram below. This flexible connector accommodates the normal expansion of the system. Before attaching the oil connector verify that any high-pressure testing has been completed.

- Do not high pressure test the oil piping with the burner connected. Failure to follow these instructions can result in property damage.
- Check the pipe and tubing ends for leaks before placing heating equipment into service. The loop of the oil supply flex MUST BE parallel or in line with the oil burner itself.
- The displacement as shown is for cold, non-firing condition. This displacement will vary as system heats up.
- Install fusible link valve in both the supply and return lines in accordance with all applicable codes.
- Install a fuel filter at each burner assembly as well as at the oil supply source.
- **ALWAYS USE TWO (2) WRENCHES WHEN MAKING PIPING CONNECTIONS TO THE BURNER.**
- **DO NOT APPLY PIPE DOPE TO FLARE NUT FITTINGS OF THE FLEXIBLE CONNECTOR.**

For descriptive purposes, only the Oil Inlet is shown in this illustration. The Oil Return line shall be installed in the same manner.

Flexible Oil Hose – Form connector into a lazy “U” bend as shown. DO NOT make sharp bends.

The Fusible Shut-Off Valve and oil filter must be parallel with the burner as well as the first section of radiant tube. A 2” (5 cm) cold displacement for initial setup is shown. This displacement can reduce when the system is fired.

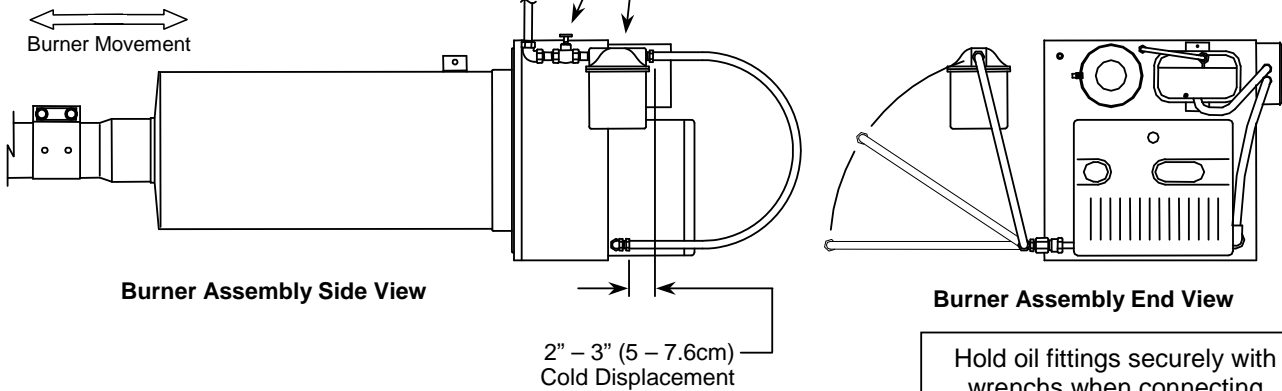

Hold oil fittings securely with wrenches when connecting flexible Oil Hose and fittings.

INCORRECT POSITIONS

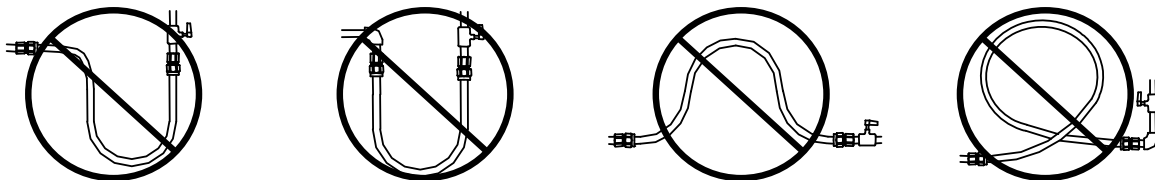

Use 36” long steel braided flexible rubber oil hose with 3/8” MPT ends for connections

COMBUSTION AIR SUPPLY

NOTICE

Air that is not contaminated must be ducted to the heater if chlorinated or fluorinated contaminants, high humidity, other contaminants, or if negative pressure is present in the area where the heater is installed.

The *Reflect-O-Ray® OIL FIRED EDS 3.5* system is certified for installation with use of inside air as well as an outside air supply system. Some compounds such as halogenated hydrocarbons or other corrosive chemicals in the air can be drawn into the burner and cause an accelerated rate of corrosion of various parts of the system.

If the building has a slight negative pressure or air which contains contaminants it is strongly recommended that an outside air supply be used.

It is recommended that a minimum of 48" of straight 4.0" OD inlet be installed before each burner. Installation of elbows or "bends" any closer than 48" before each burner is not recommended. If space will not permit the minimum 48" of straight inlet, install a 4" tee as shown below.

1. The outside air intake consists of: 1 – 4" Inlet hood, 1 - 24" long 4.0" Dia. flex duct and 2 - hose clamps.
2. It is recommended outside air intake assembly be used. This offsets problems of positive or negative building pressures, contaminated building air, etc. Combustion air may be drawn from the space that is being heated.
3. The 4" duct assembly may extend in length of up to 100 feet by adding minimum 6" diameter sheet metal duct (P.D. 0.35" W.C. per 100 ft. of duct). A maximum of 3 elbows may be used.
4. System hanging chains must hang straight down and chain shall be closed loop type (CM Chain #3, or equal).
5. If wall is 10" or thicker, add length of appropriate diameter sheet metal duct.

DO NOT DRAW COMBUSTION AIR FROM ATTIC OR OTHER SIMILAR CONFINED SPACE.
DO NOT USE "DRYER" TYPE VINYL FLEX.
DO NOT EXCEED 24" OF FLEX.

BROODER & AGRICULTURAL APPLICATIONS

In all brooder and agricultural applications outside air for combustion must be used.

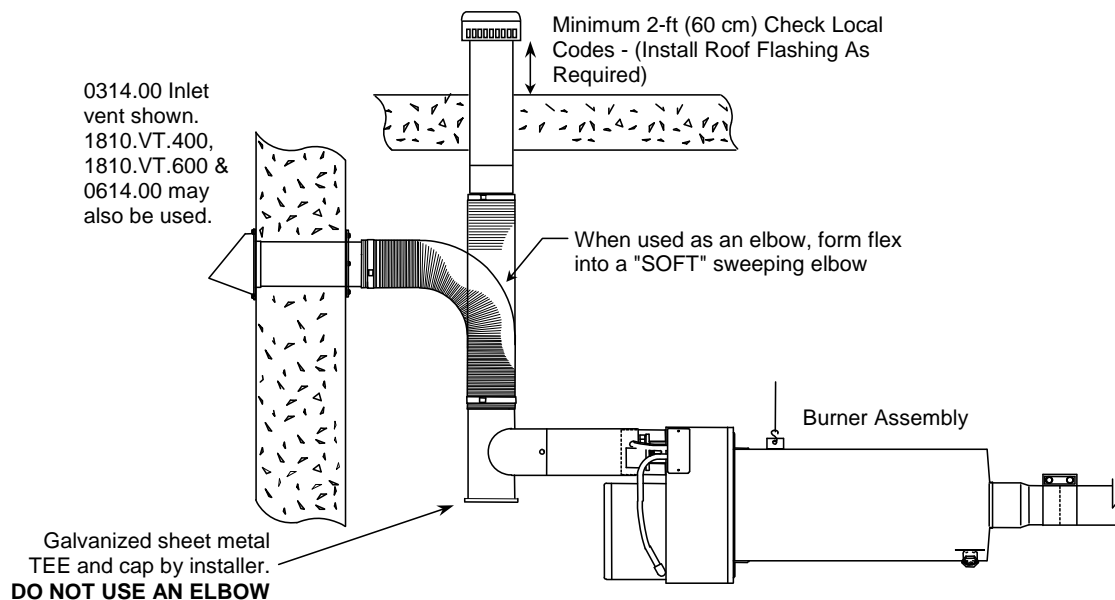
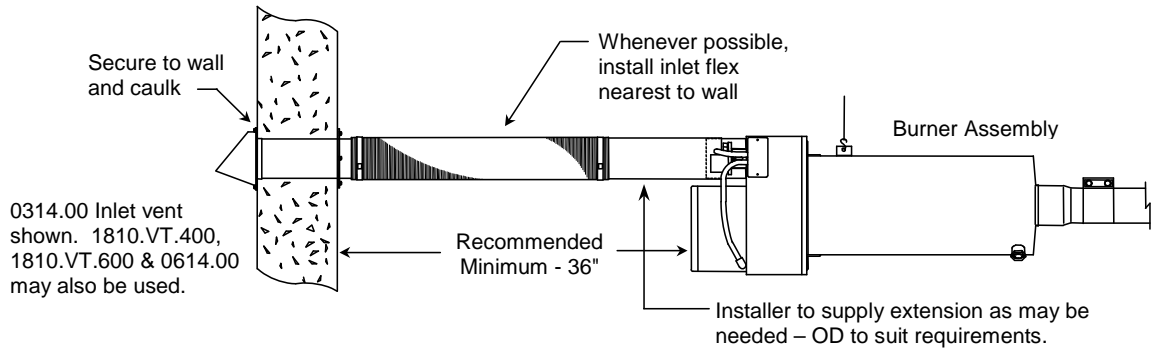

0401.WO/DI & 0402.WO/DI - VACUUM EXHAUSTERS

0401.WO/DI - ½ HP, 115 / 208-230V, 6.2 / 3.1-3.0 FLA, 60 Hz, 1 Ph., 3450 RPM, totally enclosed motor (TENV or TEFC), thermally protected.

0402.WO/DI - 1 HP, 115 / 208-230V, 12.4 / 3.0-2.7 FLA, 60 Hz, 1 Ph., 3450 RPM, totally enclosed motor (TENV or TEFC), thermally protected.

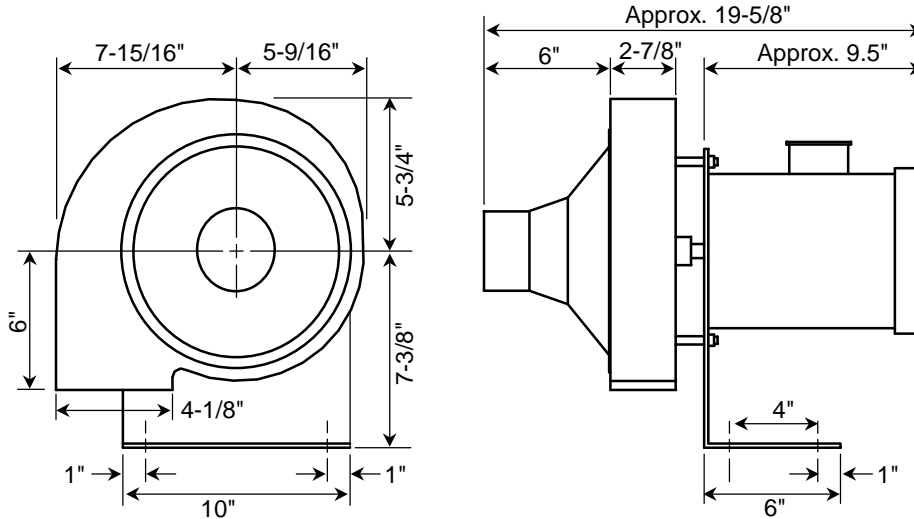

0201.WO VACUUM EXHAUSTER DATA

0201.WO - 1/4 HP, 115 / 208-230V, 3.6 / 3.0-3.0 FLA, 60 Hz, 1 Ph., 3450 RPM, totally enclosed motor (TENV or TEFC), thermally protected.

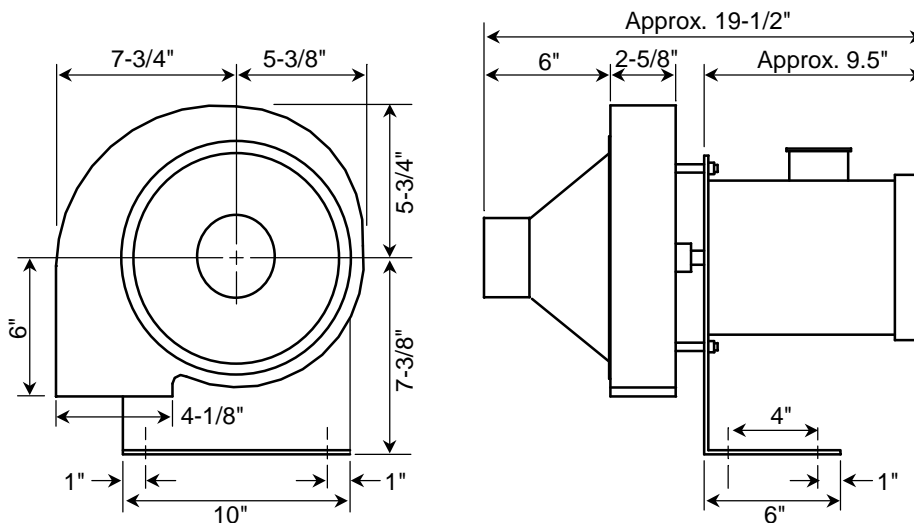

NOTE - Motor substitutions can occur, always refer to the motor manufacturer nameplate for electrical information and wiring instructions. Housings and inlets made with stainless steel are also available – the last two-digit designation will be SS.

EXHAUST FLEX CONNECTIONS

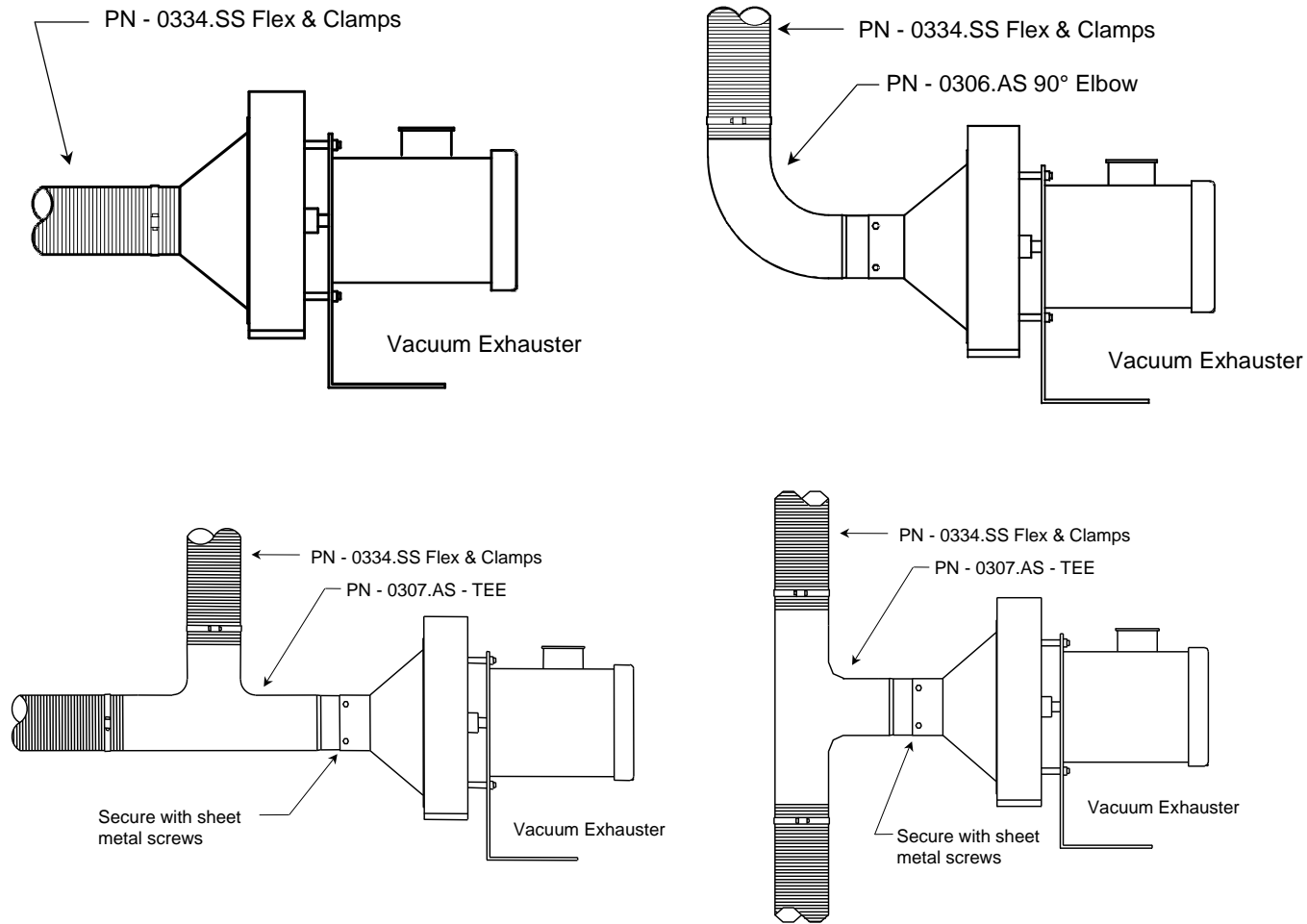

VENTING ARRANGEMENTS

⚠ WARNING



IMPROPER INSTALLATION CAN CAUSE DEATH, SEVERE INJURY AND/OR PROPERTY DAMAGE.

Improper venting and insufficient ventilation may result in health problems, carbon monoxide poisoning and death. Vent enclosed spaces and buildings according to national, state, provincial and local codes.

- ◆ This radiant heater must be vented in accordance with national, state, provincial and local codes and the guidelines in this manual. In the United States refer to the latest edition of the ANSI Z223.1 (NFPA 54) Standard and in Canada refer to the latest edition of the CAN/CGA B149.2 Standard.
- ◆ The layout drawing shows the general location of the vacuum exhauster. Specific exhauster location and discharge details must meet the following criteria:
- ◆ Make sure that the venting method selected is in compliance with local codes.
- ◆ Heater may be vented to the outdoors vertically or horizontally. The vent piping shall be adequately supported to prevent sagging.
- ◆ Horizontal discharge is preferred through side walls. The footage of horizontal vent pipe should be calculated into the maximum system footage as outlined in the charts on page 3. Vertical discharge must be arranged as shown on page 28.
- ◆ Where the vent pipe passes through areas where the ambient temperature is likely to induce condensation of the flue gases the vent pipe shall be insulated.
- ◆ If the heater is to be vented horizontally:
 - a. Vent must terminate at least 3 feet (0.9m) above any forced air inlet located within 10 feet (3.1m).
 - b. Vent shall terminate at least 4 feet (1.2m) below, 4 feet (1.2m) horizontally from, 1 foot (30cm) above any door, window, or gravity air inlet into any building.
 - c. The bottom of the vent terminal shall be located at least 12 inches (30cm) above grade and at least 6 inches (15cm) above anticipated snow depth.
 - d. Distances from adjacent public walkways, adjacent buildings openable windows and building openings, are to be consistent with ANSI Z223.1 (NFPA 54) Standard and the CAN/CGA B149.2 Standard.
 - e. Vent must not terminate less than 6-ft (1.8m) from a combustion air inlet of another appliance.
 - f. Vent must not terminate above a gas utility meter or service regulator.
 - g. Vent terminal shall not be less than 7-ft (2.1m) above grade.

- ◆ Vent opening must be beyond any combustible overhang.
- ◆ Any portion of the flue pipe that passes through combustible material of the building must have a minimum 1" clearance.
- ◆ If condensation within the flue becomes a problem, the flue should be shortened or insulated.
- ◆ Building materials should be protected from degradation by flue gas products.

Recommended practice is to mount the vacuum exhauster on the building inside wall. Alternatively the vacuum exhauster may be suspended from the ceiling.

The vacuum exhauster can be mounted outside either on roof or out side wall. The vacuum exhauster must be protected from weather by mounting a hood over the entire assembly. Vacuum exhausters are shipped completely assembled. Scroll can only be rotated in 90° increments.

The vacuum exhauster shall be installed so that the discharge is bottom horizontal. Any other arrangement will permit condensation to collect in scroll and cause premature failure of scroll. For minimum corrosion of scroll when mounted outside and the metal temperature of the scroll is less than 150°F, it is recommended that the casing be suitably insulated for protection against the weather.

Motor and exhauster impellers are precision balanced and bench tested as a complete assembly for vibration and noise. It is important that care be used when handling the vacuum exhauster to insure that it is not put out of balance by dropping or careless handling.

Install the vibration isolating stainless steel flex (PN 0334.SS) as may be shown in the layout drawing. The stainless steel exhaust flex is to be installed in a straight line, rather than formed into an elbow.

The PN 0219.00 & 0419.00 exhaust vents are provided with stainless steel bird screen as standard when furnished by Combustion Research Corporation.

OPERATION

1. Before connecting the motor to the electric supply, check the electrical characteristics as indicated on the motor nameplate to insure proper voltage, phase, and rotation.
2. After electrical connections are completed, momentarily apply power, just enough to start the vacuum exhauster unit. Be sure that the rotation of the wheel is correct as indicated by directional arrows on the unit. If proper rotation, apply full electrical power.
3. With the complete system in full operation and all ducts attached, measure current input to the motor and compare with the nameplate rating to determine if the motor is operating under safe load conditions.

VENTING ARRANGEMENTS

For Reflect-O-Ray® OIL FIRED EDS 3.5 Systems

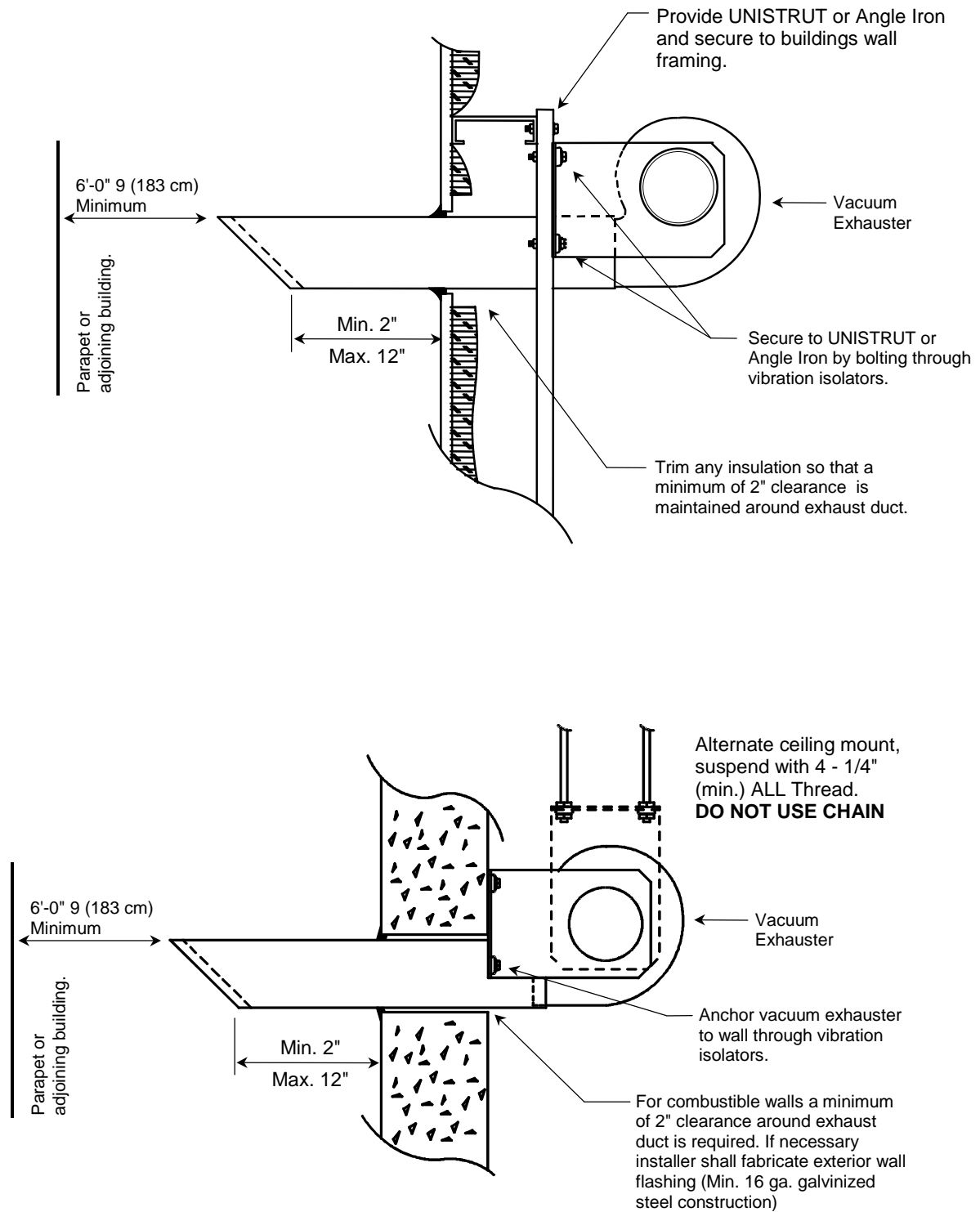

VENTING ARRANGEMENTS

For Reflect-O-Ray® OIL FIRED EDS 3.5 Systems

Use a Maximum of 20' of vent pipe for the Reflect-O-Ray® systems.

1/4HP and Larger Vacuum Exhausters, Suspend with a Quantity of 4 - 1/4" (min.) ALL Thread – Length to Suit.

DO NOT USE CHAIN

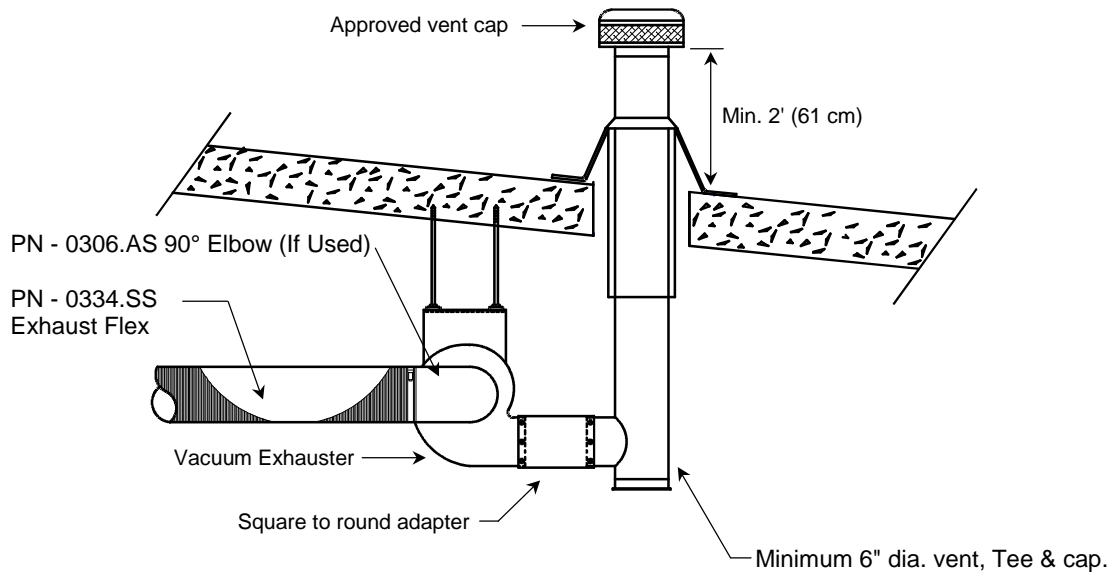
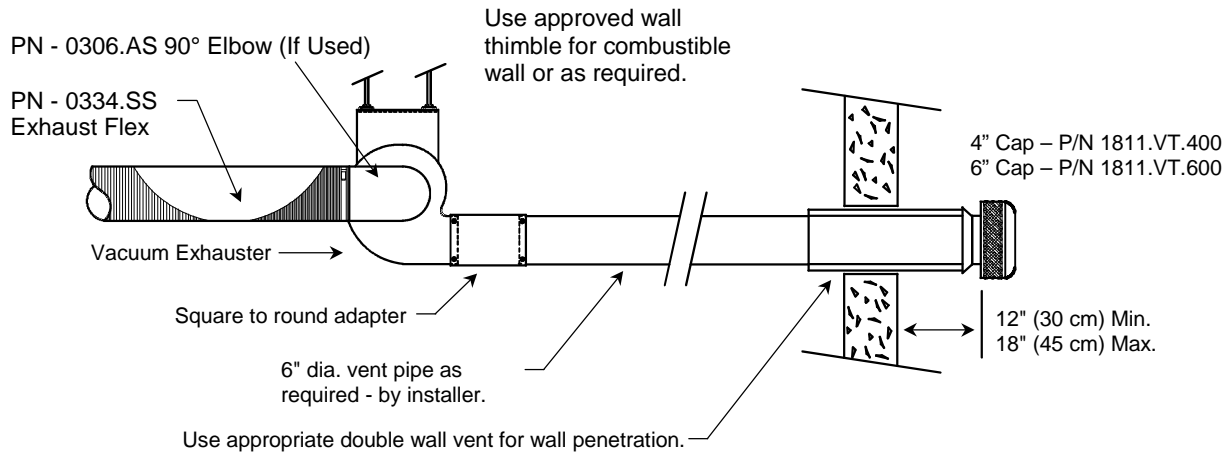

VACUUM EXHAUSTER EXTERIOR MOUNTING

The *Reflect-O-Ray® vacuum exhauster* can be mounted on the exterior of the building provided appropriate weather covers are installed. The vacuum exhauster is to be mounted bottom horizontal discharge. It is recommended that all exterior ducting be insulated or use double wall vent pipe. Weather covers are to be

fabricated from 16 gauge hot-dipped galvanized steel. Caulk all seams.

To accommodate expansion and vibration install the 0334.SS exhaust flex below the roofline.

Maintain a minimum of 3 feet (92cm) above exhaust outlet to roof or overhang and a minimum of 6 feet (184cm) to adjoining building or parapet. Exhaust outlet must be at least 6" (15cm) above anticipated snow depth.

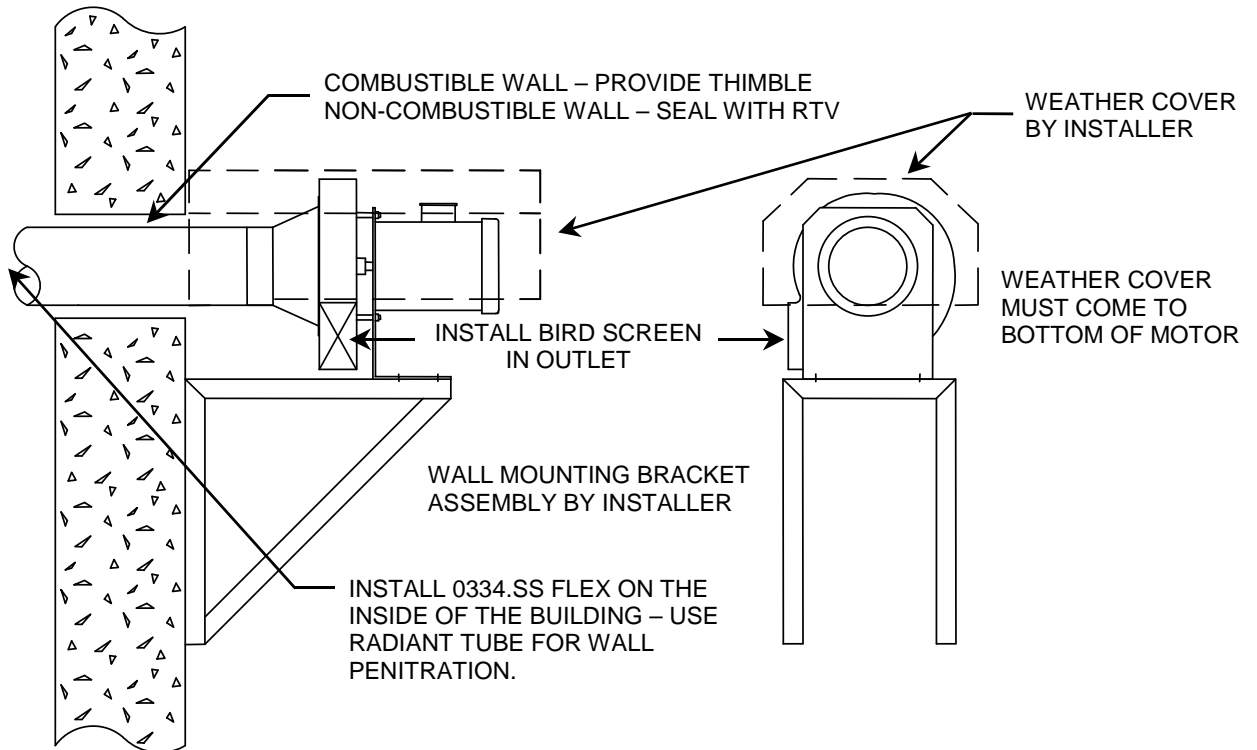
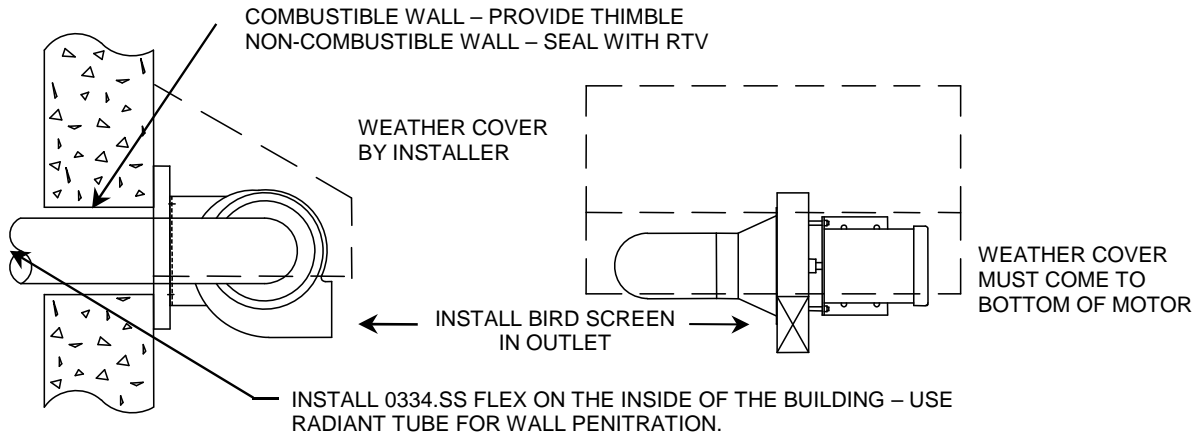

ELECTRICAL WIRING CRITERIA



WARNING

ELECTRICAL SHOCK HAZARD



**DANGER OF SEVERE INJURY
OR DEATH**

Field wiring to the heater and vacuum exhauster must be connected and grounded in accordance with national, state, provincial, local codes and to the guidelines outlined in this manual. In the United States refer to the most current revisions to National Electric Code and in Canada refer to the most current revisions to the Canadian Electric Code Part I Standard.

DO NOT use unless electrical wiring complies with all applicable codes.

DO NOT wire without providing for a power source disconnect at the burner assembly and the Vacuum Exhauster.

The requirements and practices described below are based on the National Electrical Code ANSI/NFPA No. 70- (current standard) and the Space Heating Standard or the Underwriters Laboratories, Inc. (UL), the Canadian Electrical Code CSA C22.1 Part 1 (current standard) apply in Canada. Although UL & CSA requirements are uniform throughout the country, local electrical codes may deviate from these codes, therefore local inspection authorities should be consulted regarding local requirements.

After final assembly and before shipping, each *Reflect-O-Ray® OIL FIRED EDS 3.5* burner must pass a 500 volt minimum dielectric test.

VACUUM EXHAUSTERS

Safety control circuits must be a two-wire, with ground, and have a nominal voltage not exceeding 125 volts. A safety control or protection device must be connected so as to interrupt the ungrounded conductor.

BURNERS

Safety control circuits must be two wire with ground and have a nominal voltage not exceeding 125 volts. The control circuit shall be connected to a power supply branch circuit fused at not more than the value appropriate for the rating of any control or device included in the circuit.

Large enough wire must be used in connecting a *Reflect-O-Ray® OIL FIRED EDS 3.5* system. This is necessary for two reasons - carrying capacity, and voltage drop. The wire size necessary to provide carrying capacity without overheating is generally determined by the electrical code which specify a minimum wire size for the amperage used. These requirements are intended to prevent overheating and take no account of the length of wire. Most problems have been caused by voltage drop due to long runs, or low voltage furnished by the utility.

In order to assure proper operation of the electrical components of the *Reflect-O-Ray® OIL FIRED EDS 3.5 system*, it is essential that the voltage to the exhauster

motor and burner controls is sufficient. It must be within 10 percent of the nameplate rating under all conditions to assure satisfactory operation. It is preferable that it be within 5 percent. Almost all complaints of motor not starting or not reaching operating speed are caused by low voltage reaching the motor. This voltage is dependent upon three things:

1. The voltage furnished by the Power Company.
2. The size (gauge) of the electrical wiring to the motor.
3. The length of the wiring.

Warning DO NOT use 277 volt.

When supplying single phase from a three-phase system, use a suitable sized machine tool transformer to transform the 460V or 230V three-phase to 230V or 115V single phase. Under no circumstances use 277V single phase input to the *Reflect-O-Ray® OIL FIRED EDS 3.5* system. The resulting output from a two-to-one transformer would be 138V single phase. These high voltages exceed the allowable 10% voltage variation from the normal and will damage the electrical components.

BURNER GROUNDING

It is necessary for the circuit ground, (L2) and chassis ground to be common and maintained to an earthen ground rod using copper (not aluminum) ground wires throughout. Do not assume ground continuity to an earth ground via oil supply piping, burner tubes, electrical conduits or building structural steel. These should not be assumed as proper positive earth grounds.

The correct size wire should be carefully selected before the installation is made. The first step is to establish what voltage will be coming into the building. This will vary throughout the country and must be determined locally by checking with your power company and using experience gained with other installations in your geographic area. Once the minimum voltage available is established, you will know how much voltage drop can be permitted in the wiring. The following chart shows maximum wire lengths (one way, not the length back and forth to the t/stat) to keep voltage drop to a minimum of 10 percent at various currents at 115V.

The lengths shown in the following chart should never be exceeded and in many cases it will be necessary to reduce them to accommodate low voltage supplied to the building. If 5 percent voltage drop is desired, the lengths will be one-half of those shown. Permissible lengths for other voltage drops will be in the same proportion, i.e., 8 percent = 80 percent of length shown, etc.

WIRE LENGTH FOR 10% VOLTAGE DROP IN FEET - 115V 60HZ				
AMPERES	COPPER WIRE SIZE			
	No. 14	No. 12	No. 10	No. 8
15	150	225	350	600
20	110	175	275	450
25	90	140	225	350
30	75	125	150	300
35	-	100	135	250
40	-	85	125	225
45	-	-	110	200
50	-	-	-	175

The performance of an electric motor drops rapidly as the voltage at its terminal is reduced. A 10 percent drop in voltage reduces its output by about 20 percent. In order to ensure proper operation, the motor must receive as close to nameplate voltage as possible during start-up when the amp draw is at its highest.

AMPERE REQUIREMENTS OF Reflect-O-Ray® COMPONENTS

- ◆ All Reflect-O-Ray® Oil Fired EDS 3.5 burner assemblies - 115V - 1.6 amp (4.0 FLA)
- ◆ 0402.WO/DI/SS - 1 HP Vacuum Exhauster FLA - 12.4/6.7 amps 115V/230V
- ◆ 0401.WO/DI/SS - 1/2 HP Vacuum Exhauster FLA - 5.4/3.0 amps 115V/230V
- ◆ 0201.WO/SS - 1/4 HP Vacuum Exhauster FLA - 3.6/1.8 amps 115V/230V
- ◆ 5487.00 - Thermostat Contact rating 16 amps – 24 VAC to 115 V.A.C.
- ◆ 5484.00 - Thermostat Contact rating 9.8 amps – 24 VAC to 115 V.A.C.

BASIC SYSTEM HOOK-UP

! WARNING

FIRE OR EXPLOSION HAZARD



IMPROPER INSTALLATION, ADJUSTMENT, ALTERATION, SERVICE OR MAINTENANCE CAN CAUSE DEATH, SEVERE INJURY AND/OR PROPERTY DAMAGE.

The thermostat must control both the Vacuum exhauster and Burner(s). **DO NOT CONTROL SEPARATELY. Burner(s) MUST NOT be wired "HOT".** Refer to the electrical wiring section of this manual.



Referring to the following diagram, we see a basic configuration that uses a line voltage thermostat to control power supply to the vacuum exhauster and burner transformers. Typically the burner transformers are mounted near the vacuum exhauster.

The **THERMOSTAT DIRECTLY POWERS BOTH THE VACUUM EXHAUSTER AND THE BURNER(S)**. Burners must not be wired "HOT".

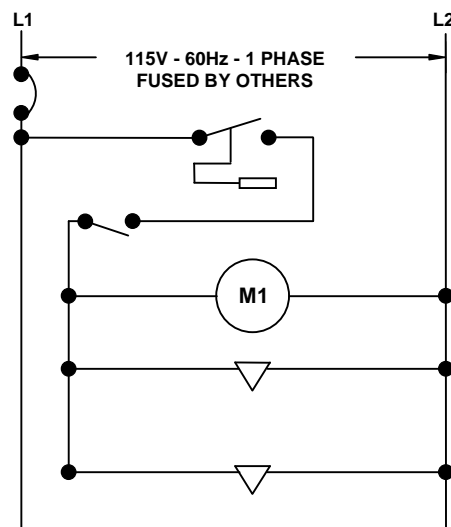
Consult the factory for alternate voltage requirements.

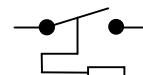
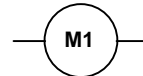

LEGEND

-  BREAKER - BY INSTALLER
-  1 POLE, 115 V THERMOSTAT
-  VACUUM EXHAUSTER 1 HP, 60 Hz, 115 VOLT
-  1 POLE 15 AMP DISCONNECT SWITCH
-  BURNER 115 VOLT

INTRODUCTION

! CAUTION

POSSIBLE BURNER DAMAGE & FAILURE

The 5500 series control panel must be used. The 5500 series control panels are designed to provide added protection for the burner combustion chamber. Primarily the post purge cycle provides period of time in which the combustion chamber cools down sufficiently so as to prevent overheating of the chamber and the burner end cone.

The basic *Reflect-O-Ray*® OIL FIRED EDS 3.5 system has a built-in pre-purge of approximately 10 air changes.

The 5500 control panel provides for additional pre purge and a post purge cycle.

The series 5500 control systems includes these basic functions:

1. Additional protection for the system.
2. Approximately 40 seconds of pre purge.
3. Approximately 40 seconds of post purge.

The pre purge and post purge cycles will provide in excess of 12 additional air changes within the combustion chamber and the radiant tubing network.

The line voltage thermostat will prevent the system from "short cycling" and allow the system to run long enough to dry out the startup condensation within the radiant tubing. The system must not be allowed to short cycle as required and outlined in the warranty statement. It is recommended that a line voltage thermostat be used when a 24V-thermostat control is required.

Please note that the timings listed may vary slightly from system to system.

**5500.00 CONTROL PANEL
PRE & POST PURGE W/115V T/STAT**

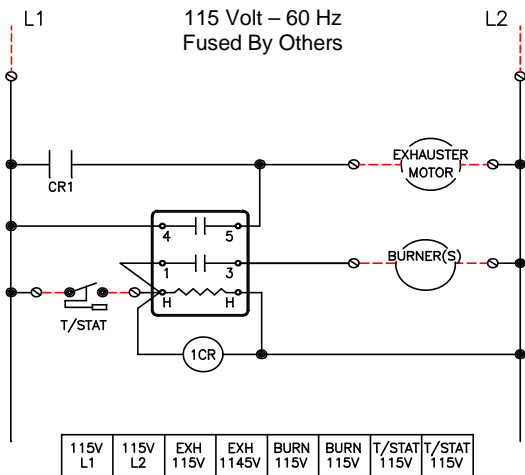

**5500.03 CONTROL PANEL
MINIMUM RUN TIME WITH
PRE & POST PURGE & 115V T/STAT**

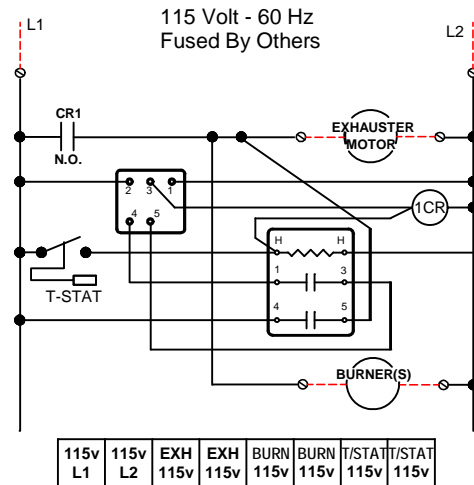

**5500.04 CONTROL PANEL
PRE & POST PURGE W/24V T/STAT**

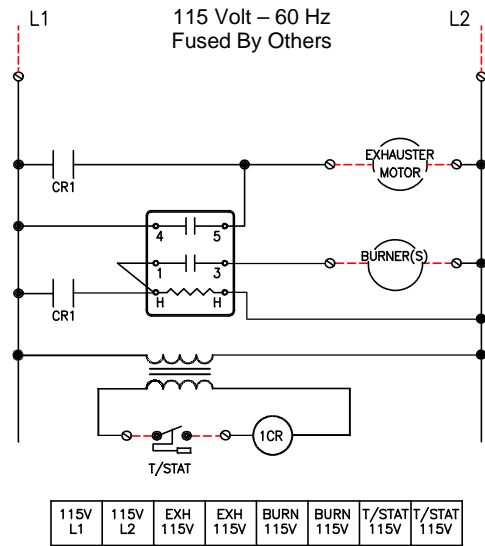

Custom control panels can be made. Consult your representative or Combustion Research Corporation with your requirements.

BURNER DIMENSIONS

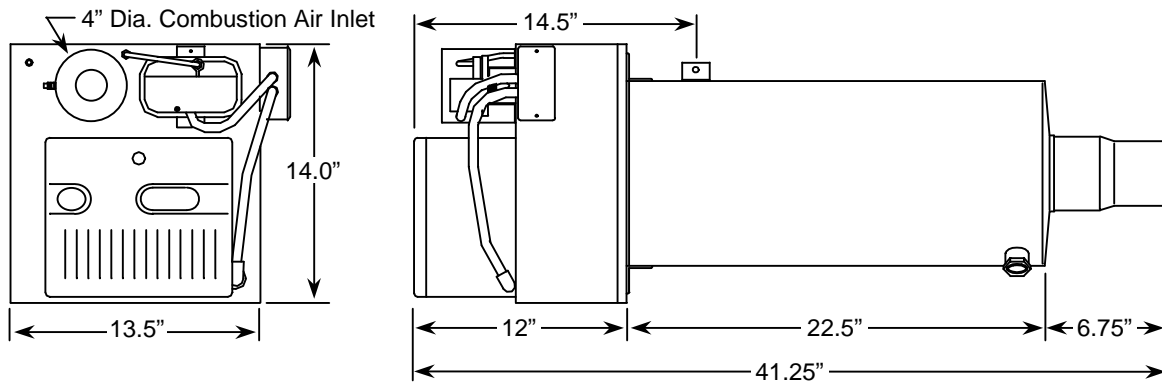

BURNER INTERNAL WIRING

POINT TO POINT DIAGRAM

115 VAC, 60 Hz., 1.6 amp

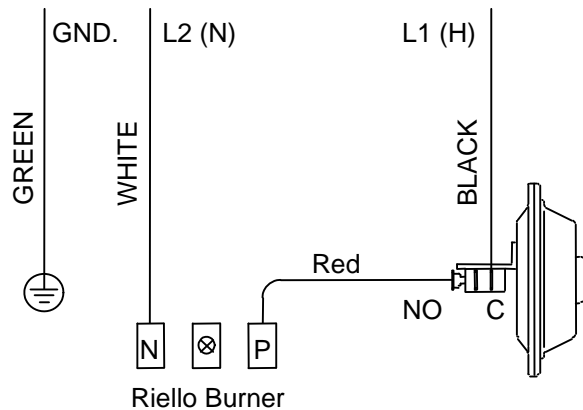

LADDER DIAGRAM

115 VAC, 60 Hz., 1.6 amp

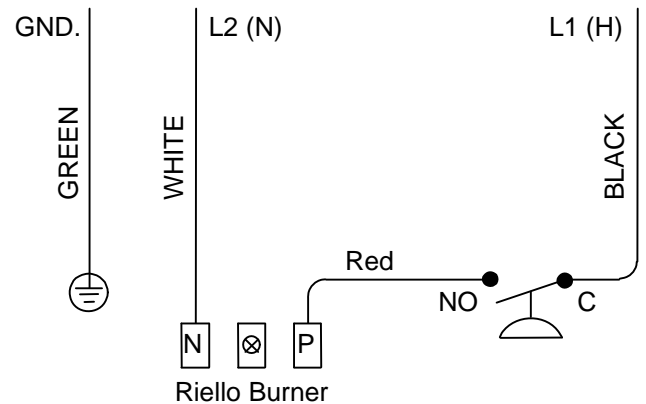

FUEL OIL CONNECTIONS

The *Reflect-O-Ray® Oil Fired EDS 3.5* system is shipped as a two-pipe system. It is strongly recommended that the system be installed as a two-pipe system. Most system failures are due to the oil delivery system. A two-pipe system greatly reduces the possibility of air entrapment within the burner pump.

An external, appropriately listed and certified oil filter and fusible link valves must also be installed at each burner assembly. The oil filter is to be installed in the INLET/SECTION line to the pump. Install a fusible link valve up-stream of this filter.

Pipe dope or Teflon tape is NOT to be used on any direct oil connection to the pump. Use the NPT/METRIC adapters connected to the oil connection lines for connecting the fuel supply and return lines.

Pipe dope or Teflon tape may be used on the NPT side of the connector only. **NOTE: Use pipe dope or Teflon tape**

carefully and sparingly so that none will get into the oil pump assembly.

Refer to pages 22 & 42 for oil supply and oil connection information.

Riello Oil Pump

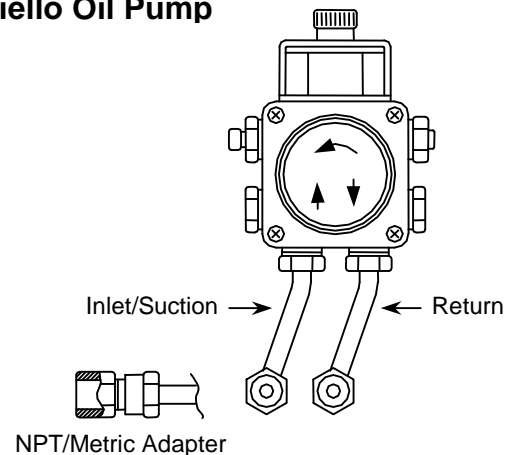

BURNER SETUP DATA

Each *Reflect-O-Ray® Oil Fired EDS 3.5®* burner assembly is marked with the input firing rate and fuel designation on the name plate. Refer to the following chart for correct manifold pressure and vacuum readings.

When the system is equipped with fresh air inlet ducting, the vacuum reading must be read as a differential across the entire burner. Use the 1/8" NPT (3.2mm) test plugs located on the 4" dia. inlet and air box of the burner. See diagram below. Each *Reflect-O-Ray® Oil Fired EDS 3.5* burner assembly is marked with the input firing rate and

fuel designation on the nameplate. Refer to the following chart for correct manifold pressure and vacuum readings. Use only #2 Fuel Oil (@ 140,000 Btu/Gal.). Do not attempt to burn waste oil, garbage, or paper with this system.

When the system is equipped with fresh air inlet ducting, the vacuum reading must be read as a differential. Use the 1/8" NPT (3.2mm) test plugs located on the 4" dia. inlet and air box of the burner. See diagram below.

The following charts show two types of Riello burner heads. The MECTRON 3 (M3) head was used prior to the 93/94 heating season and the Riello 40 F3 series is used thereafter.

BURNER PART NO.	BTU/Hr INPUT	MAX. GPH	VACUUM READING HOT*
0500.R	125,000	0.89 GPH	0.4" – 0.5" W.C.
0510.R	105,000	0.75 GPH	0.4" – 0.5" W.C.
0520.R	70,000	0.50 GPH	0.4" – 0.5" W.C.

* **NOTE** – The systems must be operating for a minimum of 15 minutes prior to taking any readings. The vacuum settings are for systems equipped for use with either inside (indoor) or outside (outdoor) combustion air.

BURNER PART NO.	BTU/Hr INPUT	ELECTRICAL RATING	NOZZLE SIZE		BURNER OIL PRESSURE	
			40 F3	MECTRON 3	40 F3	MECTRON 3
0500.R	125,000	120V, 1.6 Amp. (4.0 FLA)	.70-60° HOLLOW	.70-60° SOILD	150 PSI	140 PSI
0510.R	105,000	120V, 1.6 Amp. (4.0 FLA)	.65-60° HOLLOW	.65-60° SOLID	145 PSI	145 PSI
0520.R	70,000	120V, 1.6 Amp. (4.0 FLA)	.50-60° HOLLOW	.50-60° SOILD	125 PSI	100 PSI

BURNER PART NO.	COMBUSTION AIR ORIFICE SIZE	AIR SHUTTER SETTINGS		TURBULATOR SETTINGS		ALTITUDE
		40 F3	MECTRON 3	40 F3	MECTRON 3	
0500.R	2.0"	4	7	3	3	0 - 4500FT (0 -1370 m)
0510.R	1.75"	3.6	5	2	2	0 - 4500FT (0 -1370 m)
0520.R	1.5"	2.6	3.2	0.5	0	0 - 4500FT (0 -1370 m)

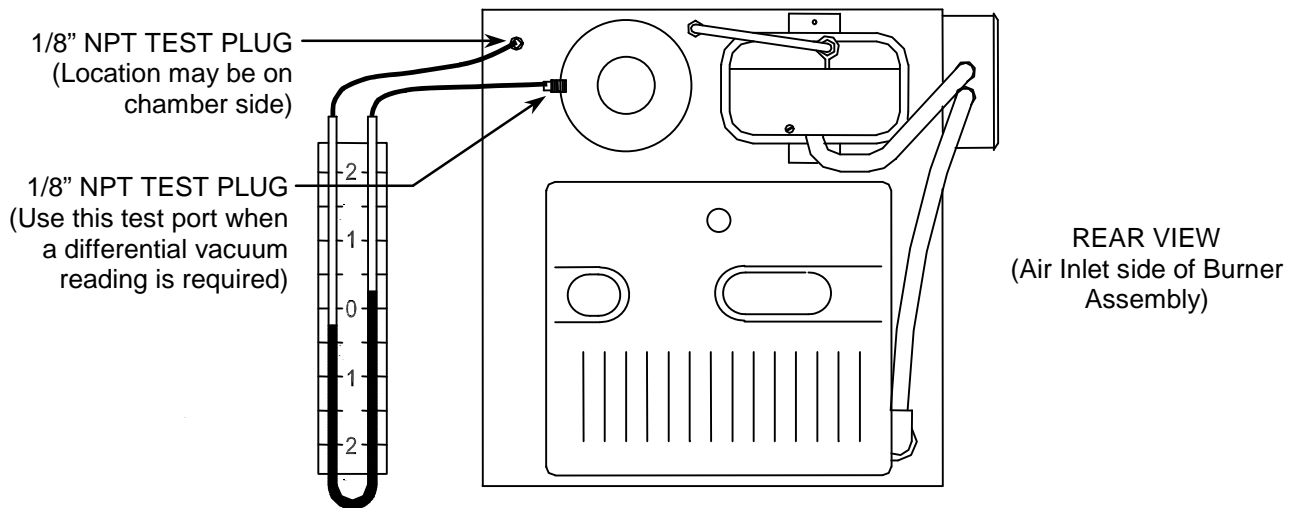

SEQUENCE OF OPERATION

1. Thermostat calls for heat.
2. Vacuum exhauster is energized.
3. Differential airflow switch proves that operation of the exhauster and the ignition control is energized.
4. After pre-purge timing, the spark igniter and oil valve are energized.
5. The ignition control senses the flame (Cad Cell) and turns off the spark ignition.
6. After the thermostat is satisfied the power is removed from the burner assembly causing the ignition control, oil solenoid valve and vacuum exhauster to be de-energized.
6. System waits for the next call for heat.

OPERATION

Before connecting the system to the electric supply, check the electrical characteristics as indicated on the Rating / Nameplate to insure proper voltage and oil supply.

With the system completely assembled, all ducts attached and in full operation, measure current input to the motor and compare with the nameplate rating to determine if the motor is operating at safe load conditions and not overloaded.

GENERAL SAFETY INFORMATION

1. Follow all local electrical and safety codes, as well as the National Electrical Code (NEC) and the Occupational Safety and Health Act (OSHA).
2. Burner(s) and vacuum exhauster must be securely and adequately grounded. This can be accomplished by wiring with a grounded, metal-clad raceway system, by using a separate ground wire connected to the bare metal of vacuum exhauster frame, or other suitable means;
3. Always disconnect power source before working on or near a motor or its connected load. If the power disconnect point is out-of-sight, lock it in the open position and tag to prevent unexpected application of power.
4. Be careful when touching the exterior of an operating motor. It may be hot enough to be painful or cause burn injury. With modern motors, this condition is normal when operating at rated load and voltages. Modern motors are designed to operate at higher temperatures.
5. Protect the power cable from coming in contact with sharp objects.
6. Do not kink power cable and never allow the cable to come in contact with oil, grease, hot surfaces, or chemicals.
7. Make certain that the power source conforms to the requirements of your equipment.

8. When cleaning electrical or electronic equipment, always use an approved cleaning agent such as dry cleaning solvent.
9. Not recommended or certified as an explosion proof blower.

MAINTENANCE

WARNING: ALWAYS DISCONNECT POWER SUPPLY BEFORE SERVICING THE BLOWER OR WORKING WITH THE UNIT FOR ANY REASON. THIS IS ESPECIALLY IMPORTANT WITH UNITS EQUIPPED WITH AUTOMATIC RESET THERMAL PROTECTION. UNIT MAY ACTIVATE WITHOUT WARNING!

! WARNING

FIRE OR EXPLOSION HAZARD



IMPROPER INSTALLATION, ADJUSTMENT, ALTERATION, SERVICE OR MAINTENANCE CAN CAUSE DEATH, SEVERE INJURY AND/OR PROPERTY DAMAGE.

Use only clean filtered #2 Fuel Oil. Do not attempt to burn waste oil of any sort, garbage or paper in the burner assembly.

PRE-CONDITIONS TO BE CHECKED BEFORE BURNER SYSTEM STARTUP

1. System has been installed to Combustion Research Corporation recommendations in Installation Manual and nameplate data.
2. The system as installed must be installed with adequate clearance to combustibles as outlined in this manual. In storage areas where stacking of materials may occur, the installer must provide signs that specify the maximum stacking height so as to maintain the required clearance to combustibles.
3. Electrical input to each heating zone is typically a 20 to 30-amp service, 115V AC/60 HZ (1-Ph).
 - a. All main disconnects closed and fuses OK.
 - b. All service disconnect switches at each burner and exhauster turned on.
4. Fuel oil supply system is free of leaks and fitted with fusible oil valves and oil filters.
5. Fuel oil supply system is free of leaks and fitted with fusible valves and oil filters.
6. All valves and fusible link valves are open. All feed lines must be purged clean and full of oil.
7. Exhauster has been checked for fan rotation, clockwise viewed from motor end.
8. Flex connection to fan inlet secure and free of leaks.
9. Blast damper pinned, secured and set so that the vacuum cannot be altered.

Notes

1. Before attempting to recycle unit after a nuisance shut down: On flame failure or expiration of trial ignition, electrical supply power to burner must be interrupted for 5 minutes to allow safety switch to reset. Power can be interrupted at burner service switch or at the thermostat. Do not reset control more than 2 times as accumulation of oil in the combustion chamber can and will occur. Contact service personnel for assistance.
2. Do not attempt to field repair control components. It is recommended defective components be replaced as factory replacement units.

A. PRELIMINARY REQUIREMENTS PRIOR TO STARTING SYSTEM

1. The system must be installed in compliance with clearances to combustibles (see pages 4 - 6). Units installed in public garages should be in accordance with the ANSI/NFPA 88A-current standard for USA and CAN 1-B149.1 or .2 for Canada. Units installed in aircraft hangars should be in accordance with ANSI/NFPA 409-current standard for USA and enforcing authority for Canada. All reflectors should be in position and installed according to these installation instructions.

2. Make sure all supply piping has been purged clean.

NOTE: Maximum oil supply to burner assemblies shall not exceed 3 PSI.

3. The electrical system must be installed according to local codes and the wire must be adequately sized for the installation in accordance with the Electrical Wiring Specification in the Installation Instructions and Start-Up section of this manual. See that the fan is correctly wired so the exhauster is running in the correct direction and that none of the equipment is pulling more than the specified capacities stated in the Electrical Wiring section mentioned above.
4. Adjustment of the damper on system is required so that proper air flow for each burner is obtained.

B. TO START SYSTEM

1. Check to insure that oil supply system is in operation.
2. Check all burners to insure that fusible oil valves at each burner are open.
3. Turn the main power switch to ON and check fuses.
4. Set the thermostat higher than the existing temperature of the area to be heated. The following steps should then take place automatically:
The vacuum exhauster is powered and will start. The vacuum created by the exhauster pulls in the burner air flow switch and supplies power to the ignition control, opening the oil solenoid and generating spark for ignition. The spark will ignite the oil.
5. Check all burners to see that they are operating. Flame should be visible through the view window.
6. Set the thermostat down to the desired temperature.
7. When the system is initially fired, any oil that is on the pipe work and fittings will burn off and form a light haze in the building which can best be removed by ventilation system in the building, or opening doors. This is a one time problem and will not recur.

8. Burner tube may have a faint red glow in a darkened room (950°F approx.).
9. On start-up there will be condensation in system for approximately 2 minutes as fan discharge temperature gets above the condensation point. The condensation will be dried up in the pipe and discharged through the fan. This results in a slight spitting of this moisture out of the fan discharge for approximately 4 minutes from initial start-up.

C. RESETTING THE FLAME SAFETY CONTROL

The *Reflect-O-Ray® Oil Fired EDS3.5* burner system is equipped with an automatic lockout control which is activated after 5 seconds if the burner should fail to ignite. If your burner should lock out, it should be reset by the follow method:

1. Make sure that the vacuum exhauster is operating. The reset button on the back of the ignition control will be lit (red LED lamp/button) signifying lockout.
2. Wait five minutes. Press the reset button and the ignition sequence will start. Ignition should occur. **Do not reset the burner more than two times.**
3. The system will now automatically recycle on the thermostat to maintain desired room temperature.

IF THE BURNER WILL NOT LIGHT AFTER TWO RESET TRIALS, CONTACT YOUR INSTALLER FOR SERVICE.

D. STOPPING THE SYSTEM FOR SERVICE

1. For servicing an individual burner or exhauster, turn off the service toggle switch that should be mounted within two feet of the unit. Close the oil supply valves at the burner assembly.
2. To service the thermostat, turn off the electrical power at the main power disconnect box.
3. Before servicing any fuel oil component; shut off the oil supply and remove all electrical power.

CHECK SAFETY SHUTDOWN PERFORMANCE

NOTE: Read steps 1-7 below before starting safety shutdown or safety lockout tests for the direct ignition (DI) module.

1. Turn fuel oil supply off at the burner.
2. Set the thermostat or controller above room temperature to call for heat.
3. Watch for ignition spark immediately or following pre-purge.
4. Time length of ignition operation.
5. After the module locks out, open fuel oil valve.
6. Set the thermostat below room temperature and wait five minutes.
7. Set thermostat above room temperature. Reset the burner by pushing the button on the back of the oil burner. Operate system through one complete cycle to ensure all controls operate properly.

! WARNING

ELECTRICAL SHOCK HAZARD



DANGER OF DEATH OR SEVERE INJURY.

WARNING: ALWAYS DISCONNECT POWER SUPPLY BEFORE SERVICING THE BLOWER OR WORKING WITH THE UNIT FOR ANY REASON. THIS IS ESPECIALLY IMPORTANT WITH UNITS EQUIPPED WITH AUTOMATIC THERMAL RESET PROTECTION. UNIT MAY ACTIVATE WITHOUT WARNING!

GENERAL AND YEARLY MAINTENANCE:

At regular intervals or at least once a year the entire system should be inspected.

Reflect-O-Ray® Oil Fired EDS 3.5 BURNER ASSEMBLY:

The oil supply system should be inspected for any leaks. Oil filters and burner oil nozzles must be changed at least once ever season.

Check combustion air inlets and connecting duct work for obstructions and breakage; repair as needed.

Inspect hanging hardware, such as chains, for wear. If any wear is present, the system must not be operated until the chain(s) or associated hardware has been replaced.

Look for any deterioration in the housing assembly. Replace or repair.

Radiant Tubing:

! WARNING

FIRE OR EXPLOSION HAZARD



IMPROPER INSTALLATION, ADJUSTMENT, ALTERATION, SERVICE OR MAINTENANCE CAN CAUSE DEATH, SEVERE INJURY AND/OR PROPERTY DAMAGE.

Damaged or nonconforming radiant tubing must be replaced with appropriate product as manufactured by Combustion Research Corporation.

The *Radiant Tubing* should be inspected at the beginning of every heating season. Look for cracks, holes, physical damage, etc.. Replace as needed.

NOTE:

Use only approved *Reflect-O-Ray® OIL FIRED EDS 3.5* radiant tubing which has been specifically designed and manufactured for the *Reflect-O-Ray® OIL FIRED EDS 3.5* system. Use of substitute materials can result in an unsafe condition and will void any and all warranties.

DIAGNOSIS AND TESTING *Reflect-O-Ray® OIL FIRED EDS 3.5 BURNER ASSEMBLY:*

If the burner does not operate, a "System Check" must be made as follows:

! WARNING

FIRE OR EXPLOSION HAZARD



IMPROPER INSTALLATION, ADJUSTMENT, ALTERATION, SERVICE OR MAINTENANCE CAN CAUSE DEATH, SEVERE INJURY AND/OR PROPERTY DAMAGE.

Perform the safety shutdown test anytime work is done on a oil system.

SYSTEM CHECK

1. Check for proper installation of unit (refer to owner's manual).
2. If power is not present, check power supply to input terminals with AC voltmeter and check fuse in burner box.
3. Remove tube fitting from air switch and insert new fitting with short rubber hose attached. Normally open air flow switch can be operated with mouth vacuum to check performance. If air flow switch does not close, replace air flow switch.
4. Provided air flow switch is operating, listen for high voltage arc, an audible spark "ticking." **(DO NOT TOUCH IGNITION OUTPUT LEADS OR IGNITION ELECTRODES.)** Check to see if high voltage leaks occur at porcelains and high voltage leads.
5. If ignition arc is not present or sporadic, turn off power and check gap. It should be approximately .10 inch. **(DO NOT TRY TO MEASURE HIGH VOLTAGE OUTPUT.)** High voltage wire should not touch casing as grounding can occur when wires are wet.
6. If ignition wires and electrodes are set as above, and power is shown but no ignition arc is present, the ignition assembly is defective and the electronics should be replaced.
7. Inspect oil nozzle for correct size, replace at least once ever season.
8. Disconnect power and check spade connections or broken wires.

ELECTRONIC PROVEN SPARK IGNITION CONTROL WITH 100% LOCKOUT:

APPLICATION

The solid state ignition control will ignite the oil by spark. The oil is ignited and burns during each running cycle.

Should a loss of flame occur, the main valve closes and the burner will lockout. This control has an internal 100% lockout function to completely shut down the system should the oil fail to ignite within 5 seconds. To initiate a re-ignition trial when lockout occurs, the power must be interrupted for 5 minutes.

The solid state ignition control must not be subjected to temperatures below -40°F (-40°C) or above 150°F (66°C).

CAUTION: When servicing the Riello burner assemblies use only Riello components.

OIL SUPPLY FAILURE ON START

1. Thermostat calls for heat.
2. Airflow is proven.
3. Valve and spark are energized after pre-purge.
4. After a maximum 5 second trial for ignition, the system will lockout to completely disarm the system.
5. In order to initiate a re-ignition trial, the power must be interrupted for 5 minutes. Reset the ignition control by pushing the illuminated button on the back of the burner assembly. DO NOT push the reset button more than two (2) times.

POWER INTERRUPTION ON START:

1. No oil will flow during power interruption.
2. Normal sequence will resume when power is restored.

POWER INTERRUPTION DURING RUNNING CYCLE:

1. Valve is de-energized.
2. Valve and spark are energized when power is restored and normal sequence will resume.

TURNING OFF THE APPLIANCE:

VACATION SHUTDOWN -- Set the thermostat to the desired room temperature while you are away.

COMPLETE SHUTDOWN – Shut off the fusible link valve on each burner, shut off the main valve on the oil supply tank and remove power from the system. Follow the Lighting Procedure to resume normal operation.

⚠ WARNING

FIRE OR EXPLOSION HAZARD



IMPROPER INSTALLATION, ADJUSTMENT, ALTERATION, SERVICE OR MAINTENANCE CAN CAUSE DEATH, SEVERE INJURY AND/OR PROPERTY DAMAGE.

1. Flame is lit automatically. Do not light the flame manually.
2. Before automatic lighting of the burner inspect around the appliance for any fuel oil leaks.
3. IF YOU HAVE AN FUEL OIL LEAK:
 - ◆ Turn off the fusible oil valve at the appliance. Remove power from any oil supply system and close the valve on the main fuel tank.
 - ◆ Do not light any appliances within the vicinity of the fuel leak.
 - ◆ Contact your service technician or oil supplier for assistance. If you cannot reach your oil supplier or service technician and you have sizable fuel oil leak, call the fire department.

MAINTENANCE:

STOP: READ ALL WARNINGS

⚠ WARNING

FIRE OR EXPLOSION HAZARD



IMPROPER INSTALLATION, ADJUSTMENT, ALTERATION, SERVICE OR MAINTENANCE CAN CAUSE DEATH, SEVERE INJURY AND/OR PROPERTY DAMAGE.

Do not disassemble the oil control. The oil control contains no replaceable components. Attempted disassembly or repair may damage the oil ignition control. Improper cleaning or re-assembly may cause oil leakage. When cleaning, ensure that the burner assembly is reassembled properly and inspected for oil leaks.

Regular preventive maintenance is important in applications that place a heavy load on system controls, such as in the commercial cooking and agricultural and industrial industries because:

1. In applications where the equipment operates 100,000-200,000 cycles per year. Such heavy cycling can wear out the oil controls in one to two years.
2. Exposure to water, dirt, chemicals, and heat can damage the oil control and shut down the control system.

The Oil control Components should be replaced if:

1. It does not perform properly on checkout or troubleshooting.
2. The oil control is likely to have operated for more than 200,000 cycles.

CLEANING OF SYSTEM

Periodic cleaning of the reflectors can be done with a mild soap and water solution. Wipe excess dirt and grim off the top and underside of the reflectors which may have collected.

Burner assembly may also be cleaned in the same manner.

Do not attempt to operate system for one (1) hour after any cleaning process which may have included water.

In the unlikely event the radiant tube system requires internal cleaning a 3.5" round brush assembly must be used. Contact your representative or the factory for guidance in obtaining this brush and the appropriate method for cleaning.

MAINTENANCE PROGRAM

The maintenance program should include a regular check out of the oil control. Maintenance frequency must be determined individually for each application. Some considerations are:

1. **Cycling frequency.** Appliances that may cycle 100,000 times annually should be checked monthly.
2. **Intermittent use.** Appliances that are used seasonally should be checked before shutdown and again before the next use.
3. **Consequence of unexpected shutdown.** Where the cost of an unexpected shutdown would be high, the system should be checked more often.
4. **Dusty, wet or corrosive environment.** Since these environments can cause the oil control to deteriorate more rapidly, the system should be checked more often.

CHECKOUT PROCEDURE:

Before leaving installation, several complete operating cycles should be observed to see that all components are functioning properly.

1. Before turning on the main electrical power switch, be sure all oil supply lines are purged of air.

2. Turn on main electrical power switch and close thermostat contacts.
3. After the control is powered it will automatically energize the spark and the oil valve.
4. The Cad Cell detects the presence of the flame and the control de-energizes the spark and the valve will remain open. Check valve outlet and other downstream pipe connections for fuel oil leaks.
5. Turn the thermostat to a low dial setting to open contacts. The main flame should be extinguished.
6. For 100% shutoff check, set thermostat to low dial setting (system off). Disconnect sensing probe lead at control terminal.
7. Turn thermostat to a high dial setting to energize spark ignition and valve. The oil should ignite. After 30 seconds, the system should "lockout" and burner functions are off (no oil flow, no spark). If the system does not go into "lockout," follow the installation instructions to replace the control. Repeat the 100% shutoff check. Note blower will not shut down when ignition "lockout" occurs.
8. Set thermostat again to a low dial setting (system off), connect probe lead to control terminal. Set thermostat to normal setting to put system back in service.

CHECK SAFETY SHUTDOWN PERFORMANCE:

⚠ WARNING

FIRE OR EXPLOSION HAZARD



IMPROPER INSTALLATION, ADJUSTMENT, ALTERATION, SERVICE OR MAINTENANCE CAN CAUSE DEATH, SEVERE INJURY AND/OR PROPERTY DAMAGE.

Perform the safety shutdown test anytime work is done on a system.

NOTE: Read steps 1-7 below before starting safety shutdown or safety lockout tests for the ignition module.

1. Turn oil supply off at the burner assembly.
2. Set the thermostat or controller above room temperature to call for heat.
3. Watch for ignition spark immediately or following pre-purge. See DI module specifications.
4. Time length of ignition operation. See DI module specifications.
5. After the module locks out, open fusible link valve on the burner and ensure there is no oil flow to main burner.
6. Set the thermostat below room temperature and wait one minute.
7. Reset the burner and operate system through one complete cycle to ensure all controls operate properly.

REMOVAL AND INSERTION OF RIELLO DRAWER ASSEMBLY REMOVAL

- A. Loosen the screw (3), then unplug the control box (4) by pulling it up and back at the same time.
- B. Remove the air tube cover plate (5), by loosening the retainer screw (6).
- C. Disconnect the flared oil nut (8), from the oil pump. Slide the complete drawer assembly out of the combustion head, as shown.

INSERTION

- A. Slide the complete drawer assembly into the combustion head, as shown.
- B. Connect the flared oil nut (8), to the oil pump, tighten securely.
- C. Replace the air tube cover plate (5), and tighten the retainer screw (6). Plug the control box (4) into place and tighten the screw (3).

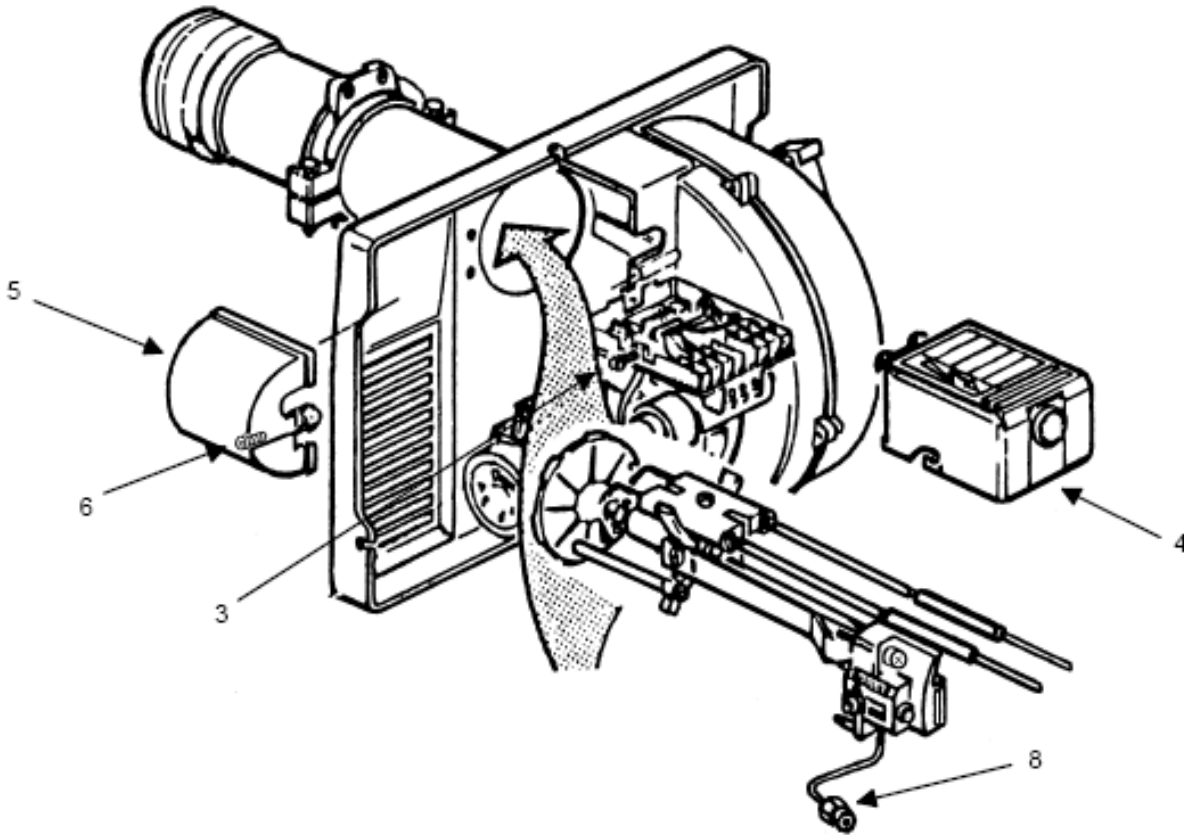

NOZZLE REPLACEMENT

- A. Determine the proper firing rate and select the appropriate nozzle as shown on page 34.
- B. Remove the nozzle adapter (2) from the drawer assembly by loosening screw (1).

- C. Insert the proper new nozzle into the nozzle adapter, tighten securely.
- D. Replace adapter, with nozzle installed, into the drawer assembly and secure with screw (1).

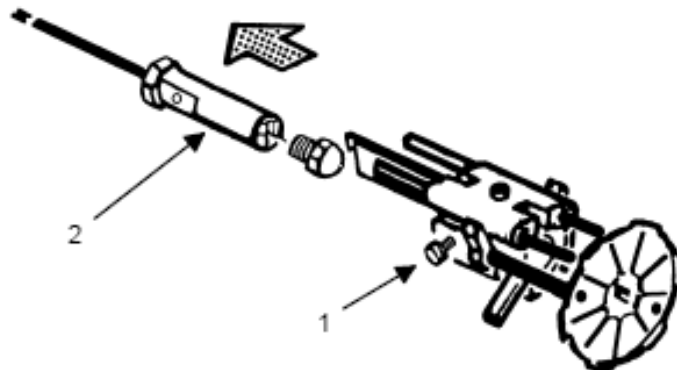

SETTING THE AIR ADJUSTMENT PLATE

Riello 40, F3 (After December, 2002)

The electric air shutter assembly (1) is operated on 120v, 60Hz gear driven motor, and the burner motor will not operate until the air shutter is in its full open position.

To adjust the air plate (4), loosen the center air shutter screw (5) and the side plate screw, move air plate (4) by using the adjustment arm on the air plate.

The proper number on the air plate should line up with the arrow (2) on the fan housing cover. Refer to page 34 for proper settings. Retighten screws (3) & (5).

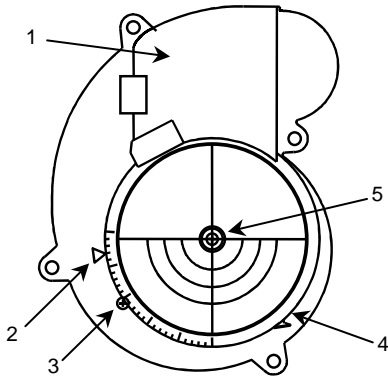

Riello 40, F3 (Pre December, 2002)

The hydraulic AIR Shutter (1) is operated by the HYDRALIC JACK (6), assuring complete opening of the air intake. To adjust the manual AIR ADJUSTMENT PLATE (4) loosen the FIXING SCREWS (3 & 5). The setting of the air adjustment plate is listed on page 34.

The proper number on the manual AIR ADJUSTMENT PLATE (4) should line up with the SETTING INDICATOR (2) on the fan housing cover. Once set, this plate must be secured in place by tightening SCREWS 3 & 5. Manually open and release the hydraulic air shutter to ensure it has free movement.

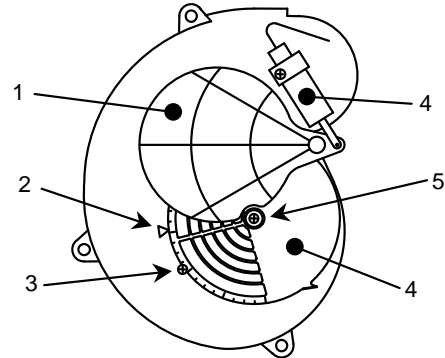

TURBULATOR SETTING

Loosen NUT (1) and then turn Screw (2) until the INDEX MARKER (3) is aligned with the correct index number as shown on page 34.

Re-tighten the RETAINING NUT (1).

NOTE: Zero (0) and three (3) are the scale indicators only. From left to right, the first line is 3 and the last line is 0.

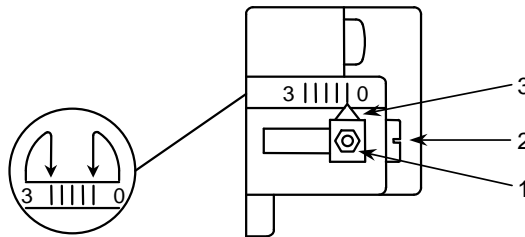

ELECTRODE SETTING

Remove the drawer assembly as described on page 40 to gain access to the spark assembly. Do not force or over tighten screws, as damage to porcelain will occur.

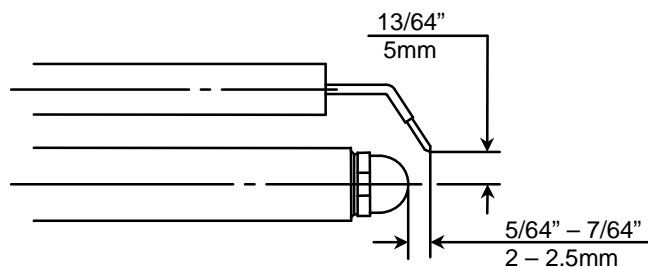
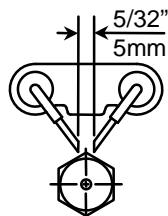

OIL PUMP

Conversion from two pipe to one pipe system.

WARNING: The burner is shipped from the factory with the pump set to operate on a two-pipe system. It is not recommended that the burner be operated as a one-pipe system.

To operate on SINGLE pipe system, the by-pass plug must be removed or damage will occur to the pump shaft seal.

Convert the pump for operation on a single pipe system by removing the by-pass plug. To remove the by-pass plug:

40 F3 BURNER ASSEMBLY

1. Remove the RETURN PIPE (1) from the pump assembly.
2. Remove the BYPASS PLUG (2) using a 2.5mm allen wrench.
3. Replace the RETURN PIPE assembly and insert a 3/8" pipe plug in the outlet (3), or contact your representative for a plug that can be inserted into the pump.

MECTRON 3 BURNER ASSEMBLY

1. Remove the PUMP COVER (1) by removing the four SCREWS (8).

2. Remove the PUMP STRAINER (2), unscrew and remove BYPASS PLUG (3).
3. Replace the strainer and pump cover. Tighten the four SCREWS (8) securely.

NOTE: Be sure the O-Ring is properly seated in the PUMP HOUSING (4) before tightening the pump cover. Pinching or damaging the O-Ring will result in an oil leak.

Connect the pipe connector to the SUCTION PORT (7) of the pump. Attach the required piping to the pipe connector. Be sure that the RETURN PORT (11) is plugged and securely tightened. Contact your representative to obtain the proper plug assembly.

NOTE: Pump pressure is set at the factory however if alteration of Btu input or conversion to single pipe system is require, the pump pressure must be set at the time of initial start-up. A pressure gauge is attached to the PRESSURE PORT (10) for pressure reading. A quantity of two PIPE CONNECTORS (6) are installed and supplied with the burner assembly. These pipe connectors are fitted with adapters (5) for connection to one female 1/4" NPT and one male 1/4" NPT. These connectors must be used. All pump port threads are British Parallel thread design. Direct connection of NPT threads to the pump will damage the pump body. Riello manometers and vacuum gauges do not require any adapters, and can be safely connected directly to pump ports. An NPT / metric adapter must be used when connecting other gauge models.

40 F3 BURNER ASSEMBLY

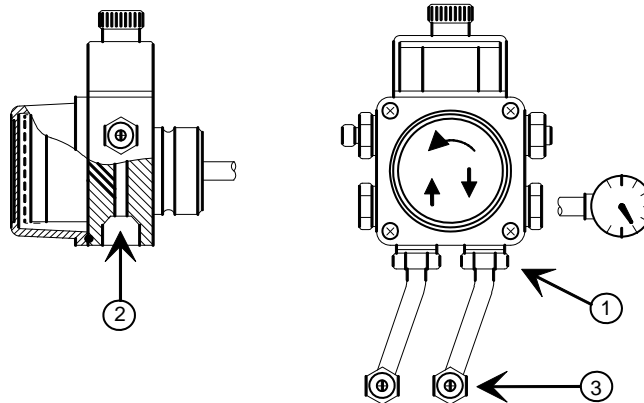

MECTRON 3 BURNER ASSEMBLY

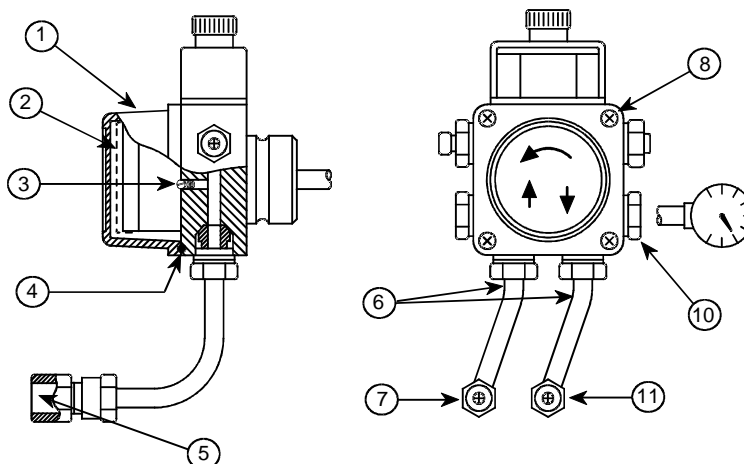

TROUBLE SHOOTING FLOW CHART

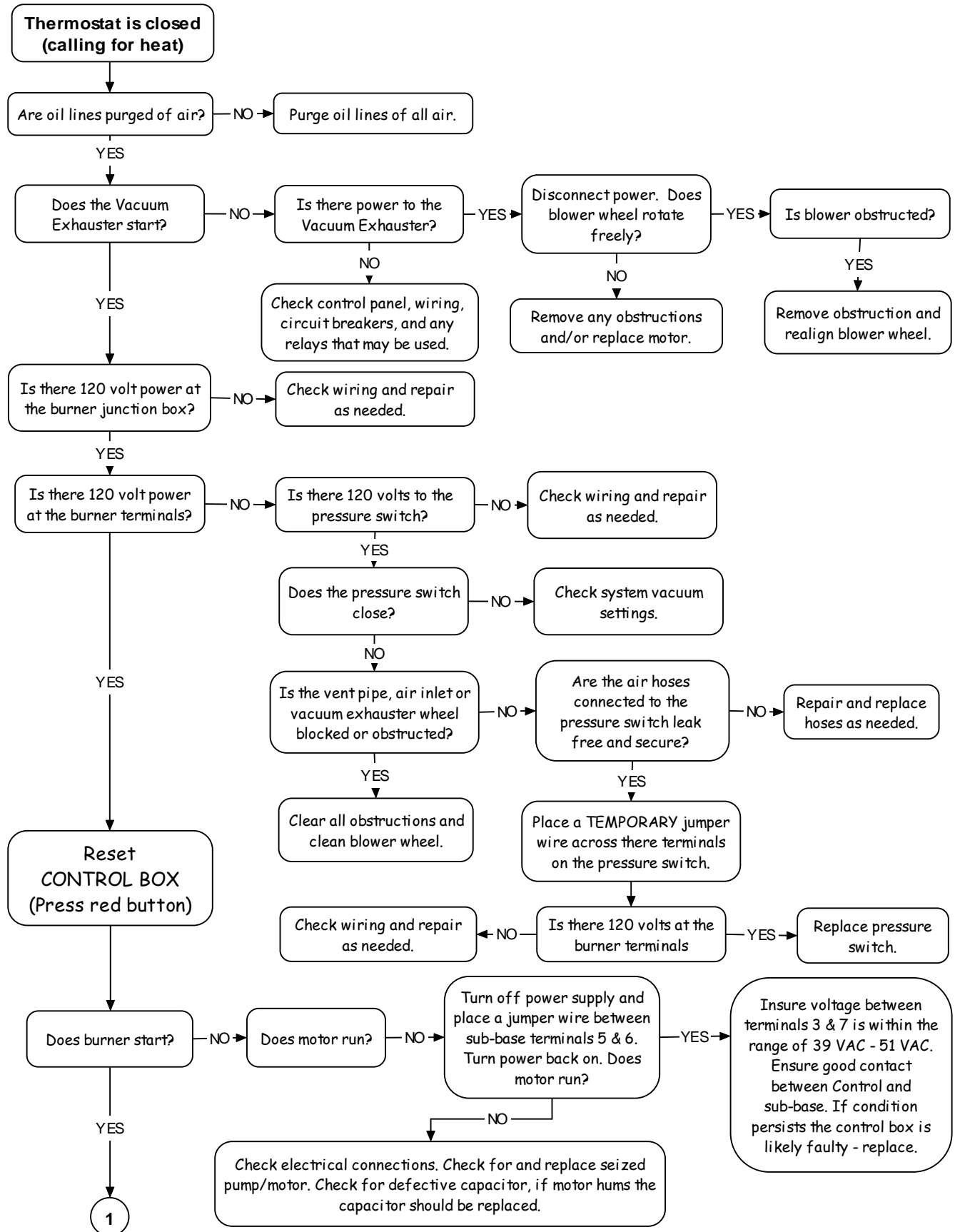

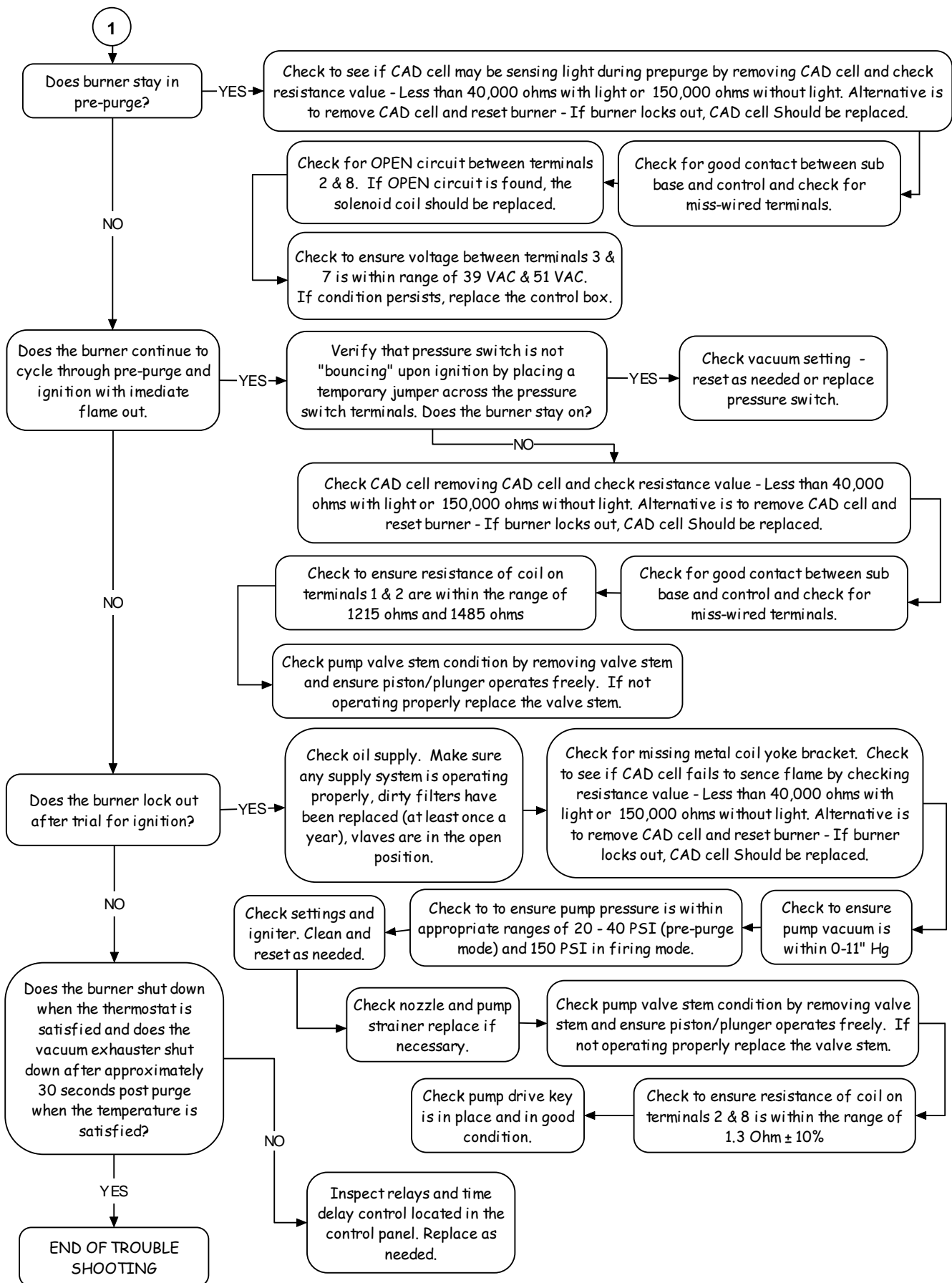

VACUUM EXHAUSTER PARTS LIST

0401.WO/DI & 0402.WO/DI VACUUM EXHAUSTER

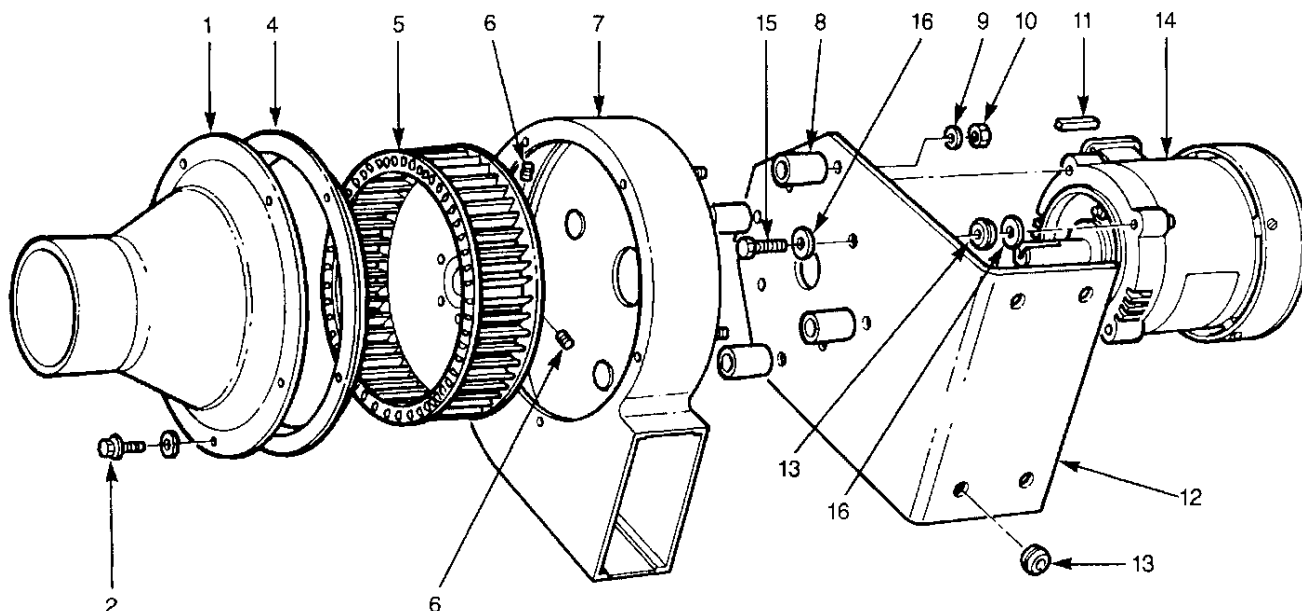

Ref No.	Part No.	Description
1	401.07	Inlet Transition (3.5" System) Double Inlet (Not Shown)
2	1141.05	Sheet Metal Screw
4	401.04	Venturi Plate
5	401.08	9-3/16" Diameter Exhauster Wheel –Stainless Steel
6	1032.03	5/16" x 18 Set Screw (Provided with exhauster wheel)
7	401.06	Vacuum Exhauster Housing
8	1463.31.25	1/2" x 1-1/4" Stand-Off
9	1122.01	5/16" Plated Lock Washer
10	1092.00	5/16" x 18 Plated Hex Nut
11	--	3/16" Key – Provided with Motor
12	201.05	Mounting Plate
13	1491.00	Rubber Grommet
14	5321.00	1/2 HP Motor – 3450 RPM – 115v/230v, 50 Hz
	5320.00	1 HP Motor – 3450 RPM – 115v/230v, 50 Hz
15	1063.11	3/8" x 16 x 1" Long Hex Bolt w/Spot Lock
16	1112.01	5/16" Plated Flat Washer

VACUUM EXHAUSTER PARTS LIST

0201.WO VACUUM EXHAUSTER

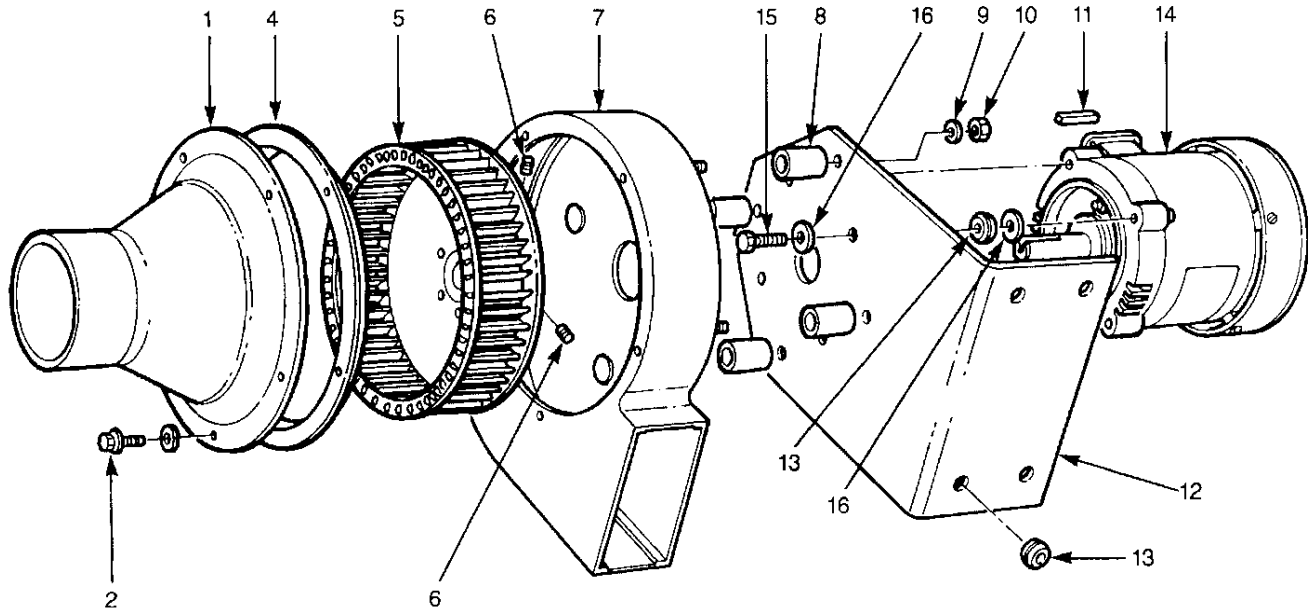

Ref No.	Part No.	Description
1	201.07	Inlet Transition (4" System)
2	1141.05	Sheet Metal Screw
4	201.04	Venturi Plate
5	201.08	9-3/16" Diameter Exhaustor Wheel –Stainless Steel
6	1032.03	5/16" x 18 Set Screw (Provided with exhaustor wheel)
7	201.06	Vacuum Exhaustor Housing
8	1463.31.25	1/2" x 1-1/4" Stand-Off
9	1122.01	5/16" Plated Lock Washer
10	1092.00	5/16" x 18 Plated Hex Nut
11	- -	3/16" Key – Provided with Motor
12	201.05	Mounting Plate
13	1491.00	Rubber Grommet
14	5323.00	1/4 HP Motor – 3450 RPM – 115v/230v, 50 Hz
15	1063.11	3/8" x 16 x 1" Long Hex Bolt w/Spot Lock
16	1112.01	5/16" Plated Flat Washer

BURNER PARTS LIST

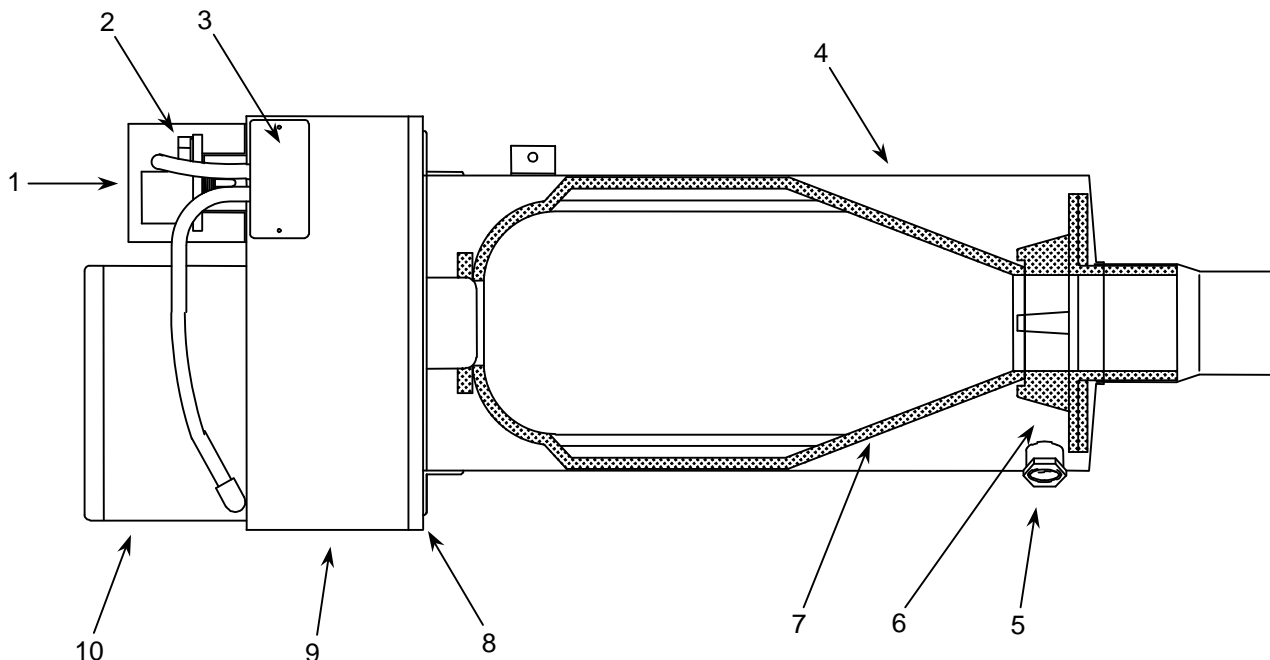



Ref. No.	Part No.	Description	Quantity
-1	500.110	Air Orifice (1.5" ID) – Used on 0520.R (70,000 Btu/Hr) Burner	1
-1	500.111	Air Orifice (1.75" ID) – Used on 0510.R (105,000 Btu/Hr) Burner	1
-1	--	No Air Orifice Used on 0500.R (125,000 Btu/Hr) Burner	-
2	5060.03C	Differential Pressure Switch – All Models	1
-3	1264.24.C	Handy Box Cover (2" x 4")	1
-3	1264.24	Electrical Handy Box (2" x 4")	1
4	500.103.A	Combustion "Can" With Flange – No Inspection Port	1
5	1300.70	Inspection Port – ¾" NPT	1
6	500.106	Combustion Chamber End Piece	1
7	500.107	Combustion Chamber	1
8	504.R1-B	Fresh Air Box Mounting Flange	1
9	504.R1-A	Fresh Air Box	1
--	500.100.R	Complete Chamber Assembly Less Riello Burner Head & Air Box	1
10	--	Riello Burner Assembly – See Next Page For Exploded View	1

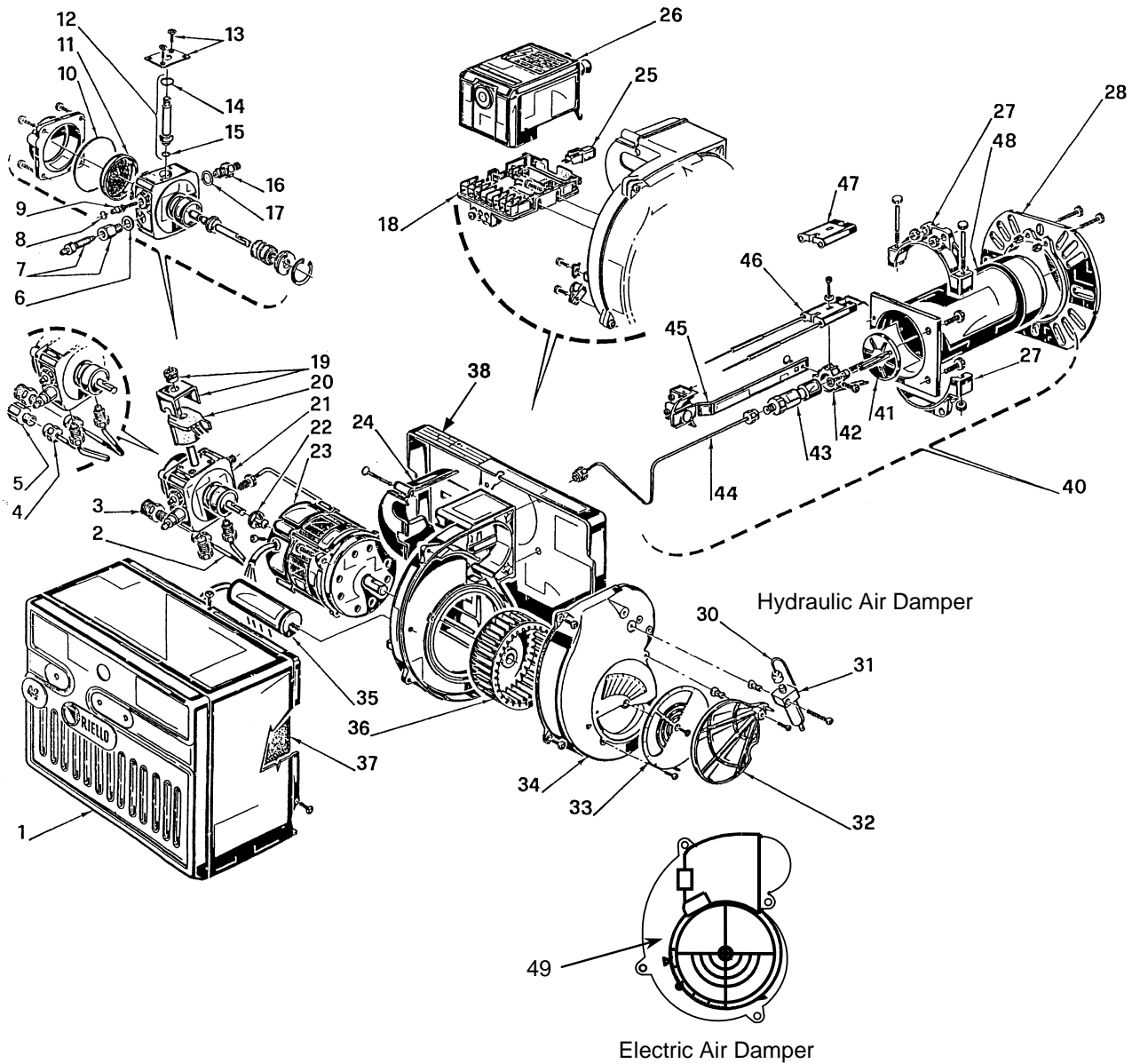

REPLACEMENT PARTS

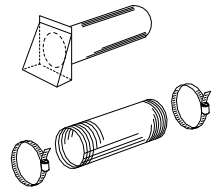
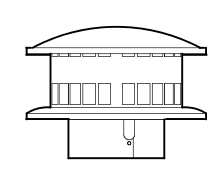
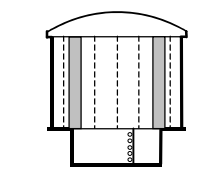
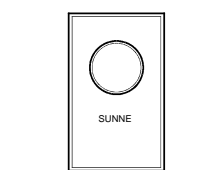
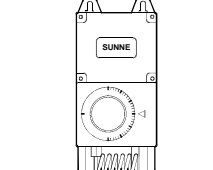
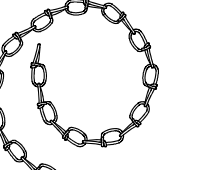

Riello 40 F3 Series

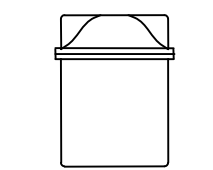

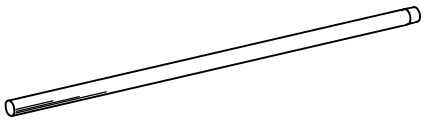
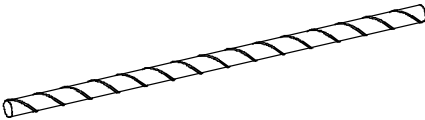
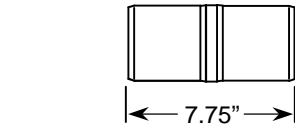
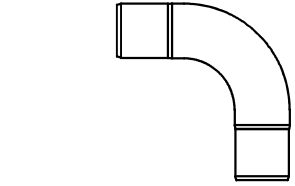
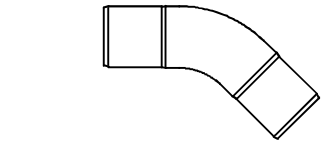
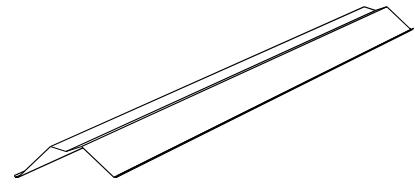
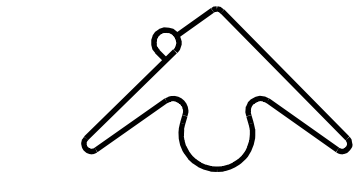
Ref. No.	Part No.	Description	Quantity
1	3007232	Burner Back Cover	1
2	3006992	Pipe Connector - Supply	1
3	3006571	¼" NPT/Metric Adapter - Male	1
4	3006993	Pipe Connector - Return	1
5	3005847	¼" NPT/Metric Adapter - Female	1
6	3007077	Crushable Metal Washer 3/8" ID	1
7	3007568	Bleeder	1
8	3007028	O-Ring – Pump Pressure Regulator	1
9	3007202	Regulator Screw	1
10	C7010002	O-Ring - Pump Cover	1
11	3005719	Pump Screen	1
12	3006925	Valve Stem	1
13	3007203	Plate – Valve Stem Upper	1
14	3007029	O-Ring - Valve Stem, Upper	1
15	3007156	O-Ring - Valve Stem, Lower	1
16	3007268	Nozzle Outlet Fitting	1
17	3007087	Crushable Metal Washer 5/8" ID	1
18	3002278	Primary Control Sub Base	1
19	3006553	Coil "U" Bracket & Retainer Nut	1
20	3002279	Coil	1
21	3007802	Pump	1
22	3000443	Pump Drive Key	1
23	300C700104	Motor	1
24	3007315	Air Tube Cover Plate	1
25	3002280	Photo Cell	1
26	C7001029	Primary Control	1
27	3005854	Semi Flange	2
28	3005855	Universal Flange Mount	1
29			
30	C7001058	Capillary Tube (Pre Nov. 1996)	1
31	3006911	Hydraulic Jack (Pre Nov. 1996)	1
32	3000878	Hydraulic Air Shutter (Pre Nov. 1996)	1
33	3007204	Manual Air Shutter	1
34	3007207	Air Intake Housing	1
35	3005844	Capacitor 12.5 MFD	1
36	3005708	Fan	1
37	C6950050	Acoustic Liner	1
38	3007221	Chassis Front Plate	1
40	3948873	Combustion Head Complete - 6" (271T1)	1
41	3006968	Turbulator Disk	1
42	3006966	Electrode Support	1
43	3006965	Nozzle Adapter	1
44	3006969	Nozzle Oil Tube	1
45	3006324	Regulator Assembly	1
46	3006330	Electrode Assembly	1
47	3005869	Electrode Porcelain	1
48	3007592	Air Tube	1
49	C7001081	40 F3 Replacement Air Damper Kit (Post Nov. 1996)	1

Part No.	Description	
0314.00	<p>FRESH AIR INLET ASSEMBLY - Weather Proof Inlet 4" dia., 12" long with 24" long PVC coated Aluminum Flex with two hose clamps, 4" diameter. WT. 2.0 lbs.</p>	
1810.VT.600	<p>ROOF OR WALL VENT - 6" diameter mushroom style round vent. For single wall or "B" Vent. Wt. 0.75 lbs.</p>	
1811.VT.600	<p>ROOF OR WALL VENT - 6" diameter – High Wind mushroom style round vent. For "B" vent. Wt. 0.75 lbs.</p>	
5484.00	<p>THERMOSTAT - Line voltage, 9.8 FLA , 50°F to 90°F Wt. 1.0 lbs.</p>	
5487.00	<p>THERMOSTAT - Line voltage, Moisture proof 16 FLA, 40°F to 80°F Wt. 1.0 lbs.</p>	
1800.CH.000	<p>HANGING CHAIN - Double loop hanging chain, 100' - work load rating of 90 lbs. – For radiant tube and reflector suspension only. Wt. 6.5 lbs.</p>	
1800.SH.000	<p>"S" HOOKS - Box of 50 "S" hooks. WT. 2.0 lbs.</p>	
1A-25A	<p>OIL FILTER – Fuel oil filter with 3/8" FPT connections. Wt. 4.0 lbs.</p>	

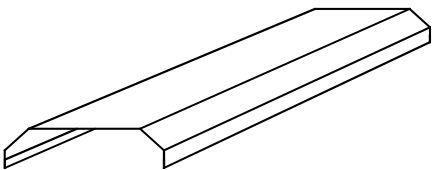
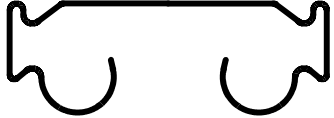
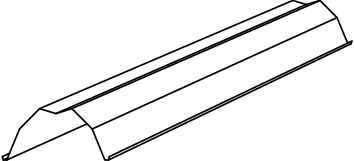
Part No.	Description	
0304.AS.16	COMBUSTION TUBE – ALUMINIZED STEEL - 3.5" dia. aluminized steel combustion tube, 10'-0" long. Wt. 25 lbs.	
0304.AS	RADIANT HEAT TUBE – ALUMINIZED STEEL - 3.5" dia. aluminized steel radiant tube, 9'-9" long. Wt. 11.25 lbs.	
0304.AS.20	RADIANT HEAT TUBE – ALUMINIZED STEEL - 3.5" dia. aluminized steel radiant tube, 19'-6" long. Wt. 22 lbs.	
0311.AS	TUBE COUPLER – ALUMINIZED STEEL - 3.5" dia. Wt. 1.5 lbs	
0306.AS	90° ELBOW - ALUMINIZED STEEL - 3.5" dia. aluminized steel, 90° elbow. Wt. 3.0 lbs.	
0336.AS	45° ELBOW - ALUMINIZED - 3.5" dia. aluminized steel, 45° elbow. Wt. 1.5 lbs.	
0360.00	STANDARD REFLECTOR - Aluminum, 10' long. Wt. 5.0 lbs.	
0361.00	COMBINATION HANGER - Heat tube & standard reflector hanger for 3.5" tube, plated 1/4" dia. wire. Wt. 0.75 LB	
0362.00	REFLECTOR SUPPORT - Intermediate support for standard reflector for 3.5" tube, plated 1/4" dia. wire. Wt. 0.75 LB	

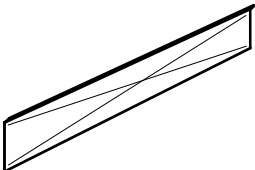
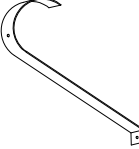
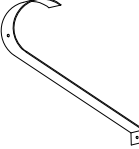
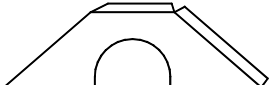
Part No.	Description	
0812.00	PANEL REFLECTOR - Aluminum, 10' long. Wt. 7.0 lbs.	
0812.02	PANEL HANGER - Heat tube & reflector hanger for 3.5" tube, plated 1/4" dia. wire. Wt. 1.0 LB	
0363.00	DEEP DISH REFLECTOR - Aluminum, 10' long. Wt. 5.75 lbs.	
0364.00	DEEP DISH COMBINATION HANGER - Heat tube & deep dish reflector hanger for 3.5" tube, plated 1/4" dia. wire. Wt. 0.75 lb.	
0365.00	DEEP DISH REFLECTOR SUPPORT - Intermediate support for deep dish reflector for 3.5" tube, plated 1/4" dia. wire. Wt. 0.75 lb.	
0367.00	SIDE SHIELD - Aluminum side shield. Used on 0360.00 & 0812.00 reflectors, 10' long. Wt. 3.0 lbs.	
0368.00	SIDE SHIELD SUPPORT - Side shield support for use with 0360.00 reflectors. Wt. 1.0 lbs.	
0368.0010	SIDE SHIELD SUPPORT - Side shield support for use with 0812.00 reflectors. Wt. 0.75 lbs.	
0342.WH	REFLECTOR END CAP - Aluminum end cap. Used on 0360 reflector. Wt. 0.25 lbs.	

- NOTES -

WARRANTY STATEMENT

Combustion Research Corporation ("CRC") offers the end-use buyers of its products a specific and limited one-year standard Warranty covering the Reflect-O-Ray® product systems or components, the details of which are given below. This Warranty is offered only to the Buyer-For-End-Use ("Buyer") and becomes effective the product is properly installed and maintained. Proper installation shall be assumed (for purposes of this warranty only) if installation is performed by a qualified installer in accordance with the owners manual as well as local, state and federal standards.

In addition, to the one-year warranty on all product components, Combustion Research Corporation also offers the Buyer an Extended Warranty on the radiant heater tubing (Infrared Emitter), which is installed as original equipment with a Combustion Research Corporation infrared radiant energy heating system. This Extended Warranty becomes effective (1) on the invoice date of the original equipment from CRC, and (2) the product is properly installed and maintained in accordance with the owners manual

This Warranty is subject to limitations and conditions which effect the Buyer's rights and which can lead to voidance of the warranty. The Buyer should read and understand these limitations.

DISCLAIMER OF IMPLIED WARRANTIES

(Please Read Carefully)

COMBUSTION RESEARCH CORPORATION ("CRC") DISCLAIMS ANY AND ALL IMPLIED WARRANTIES OF ANY KIND OR DESCRIPTION, INCLUDING WITHOUT LIMITATION WARRANTIES OF MERCHANTABILITY, FITNESS FOR A PARTICULAR PURPOSE, CONDITION, QUALITY OR DURABILITY, WHICH MAY BE PROVIDED BY LAW AS RELATES TO ALL PRODUCTS MANUFACTURED, SOLD, ASSEMBLED AND/OR PROVIDED TO THE ULTIMATE USER, TRANSFEREE, CONTRACTOR, CONSUMER, BUYER AND/OR PERSON UNDER THE LAWS OF THE STATE OF MICHIGAN AND/OR THE UNIFORM COMMERCIAL CODE. THIS DISCLAIMER MEANS NO IMPLIED WARRANTY OF ANY NATURE WHATSOEVER DEALING WITH THE ULTIMATE USE OF THE PRODUCT ASSEMBLED, MANUFACTURED AND/OR SOLD BY CRC SHALL BE GRANTED TO ANY PARTY WHO WITHOUT SAID DISCLAIMER WOULD BE ENTITLED TO BRING AN APPROPRIATE ACTION IN THE COURTS OF THE STATE OF MICHIGAN AS THE LAW SO PROVIDES. THE EXPRESS WRITTEN WARRANTY OF CRC FOR EACH PARTICULAR TRANSACTION SHALL BE THE ONLY EXPRESS WARRANTIES SO PROVIDED AND SHALL BE THE ONLY WARRANTY PROVIDED BY CRC FOR ITS PRODUCTS. THERE ARE NO WARRANTIES WHATSOEVER BEYOND THE DESCRIPTION ON THE FACE HEREOF.

DISCLAIMER OF DAMAGES

(Please Read Carefully)

IN NO EVENT SHALL CRC BE LIABLE FOR SPECIAL, INDIRECT, CONSEQUENTIAL OR INCIDENTAL DAMAGES OF ANY TYPE OR DESCRIPTION WHETHER ARISING UNDER CONTRACT, WARRANTY, TORT, NEGLIGENCE, STRICT LIABILITY OR ANY OTHER THEORY OF LIABILITY. SUCH DAMAGES INCLUDE, BUT ARE NOT LIMITED TO, LOSS OF PROFITS, LOSS OF USE OF THE PRODUCTS, DAMAGE TO PROPERTY, INCONVENIENCE AND CLAIMS OF THIRD PARTIES. SOME STATES DO NOT ALLOW THE EXCLUSION OR LIMITATION OF INCIDENTAL OR CONSEQUENTIAL DAMAGES, OR ANY LIMITATION OF INCIDENTAL OR CONSEQUENTIAL DAMAGES OR ANY LIMITATIONS ON HOW LONG AN IMPLIED WARRANTY LASTS, SO THE ABOVE EXCLUSION OR LIMITATION MAY NOT APPLY TO YOU. THIS WARRANTY GIVES YOU SPECIFIC LEGAL RIGHTS WHICH VARY FROM STATE TO STATE. HOWEVER, TO THE EXTENT PROVIDED BY LAW, MICHIGAN LAW CONTROLS ALL RIGHTS AND OBLIGATIONS HEREUNDER.

LIMITATIONS AND CONDITIONS FOR STANDARD WARRANTY.

The express written Warranty is a representation by CRC that the products, including all components, purchased by the Buyer from CRC or an authorized CRC representative are free from defects in material and workmanship. This Warranty applies to defects which are discovered either upon receipt of the product, or up to three (3) years after receipt of the product or CRC's invoice date, whichever event last occurs. If any such defect is found and the Buyer has satisfied the warranty requirement, and the warranty is not voided under any of the following conditions, CRC will replace free-of-charge, the defective part or parts. However it is not CRC's obligation to find, remove, or transport the defective part or parts. Further, it is not CRC's obligation to install or to pay for installation of any replacement part or parts. Repair or replacement of defective part or parts will only be done after CRC has determined in its sole judgment that the warranty applies.

LIMITATIONS AND CONDITIONS FOR EXTENDED 10 YEAR WARRANTY

The Extended Warranty is a special offer made by Combustion Research Corporation (CRC) to Buyers-For-End-use of CRC products to give them an extra term of replacement part protection. The Extended Warranty covers the infrared emitter tubing. The infrared tubing is guaranteed by CRC against internally created rust through corrosion (which is caused by the condensation of products of combustion inside the emitter tube when the flue gas temperature is allowed to fall below the dew/condensation point) for 10 years from CRC's invoice date. If any defect is found during this period, and if the Buyer-For-End-Use has satisfied the Warranty and Extended Warranty requirements, and if the warranty is not voided under any of the following conditions, CRC's obligation is either repair the defective part or to furnish the Buyer-For-End-Use with a

replacement part or parts. As with the Standard Warranty, it is not CRC's obligation to find, remove or transport the defective part or parts, or to pay for finding, removing, or transporting such part or parts, and it is not CRC's obligation to install or pay for installation of the replacement part or parts. Again, it is the Buyer's obligation to send the part or parts freight pre-paid to CRC.

LIMITATIONS ON STANDARD AND EXTENDED 10 YEAR WARRANTY

These Warranties are the only warranties offered by Combustion Research Corporation (CRC) and are in lieu of all other warranties either express or implied. CRC shall not be liable for any special, incidental or consequential damage, such as damage to a building or persons or things within a building due to any kind of radiant energy heating system failure. In addition, the Standard and Extended Warranties apply only to those products which are shipped to and installed in the United States & Canada.

ARBITRATION

In the event any Buyer, user, subsequent owner, transferee, installer, purchaser and/or ultimate customer experiences any problem, difficulty and/or has a complaint dealing with the use, installation and/or operation of the products sold, delivered and/or manufactured by CRC under the terms and provisions of any purchase order, contract, invoice or other document, then the differences between that person or entity and CRC shall be amicably resolved. In the event a resolution of the differences between the parties is unable to be accomplished, said matter shall be resolved through final and binding arbitration under the laws of the State of Michigan. The party complaining shall select, appoint and pay for an arbitrator. CRC shall select, appoint and pay for an arbitrator, and the two (2) arbitrators so selected shall agree upon and appoint a third impartial arbitrator. The dispute and/or matter of controversy shall be submitted to the arbitrators who by majority vote shall render a final and binding decision dealing with the controversy in existence between the parties. Said decision shall be enforceable in a Michigan Court maintaining jurisdiction over said matter under the requisite provisions of Michigan law. The costs of the impartial arbitrator shall be paid one-half (1/2) by the complaining party and one-half (1/2) by CRC.

MICHIGAN LAW TO GOVERN

This contract and/or document dealing with the purchase sale and/or installation of products sold and/or manufactured by CRC shall be governed by the laws of the State of Michigan, both as to its interpretation and performance. The place of this contract, its situs and forum shall at all times be the State of Michigan. All matters relating to the validity, construction and enforcement of this contract shall be determined in the appropriate courts maintaining jurisdiction over all controversies in the State of Michigan.

VOIDING OF WARRANTIES

Each of the following listed events, conditions, acts or omissions by any person or entity may void the Warranty:

1. Improper installation; i.e., installation which is not in accordance with the instructions in the service and installation manual.
2. Running the burner(s) with intake combustion air drawn from an atmosphere which is contaminated with halogenated hydrocarbons, fluorocarbons, or other corrosive substances.
3. Relocation or reinstallation of the product or system.
4. Use of electrical power having voltages, frequencies or transients which exceed product or system ratings.
5. Physical abuse or neglect to the product system or components of the system; i.e., allowing the product system to operate with broken or damaged system components.
6. Damage to the product system or components of the product system by fire, flood, earthquake or act of God.
7. Removal of the serial number or nameplate.
8. Refusal to permit inspection and/or service of the product system or parts by an authorized CRC representative.
9. Repair or replacement of any product components or other heating components which have been repaired or replaced with other than factory parts.
10. Designing or allowing the system to run with a "short cycle" or continuous condensing mode; i.e., using low voltage temperature controls without a minimum eight (8) minute run time which would allow the startup condensate to collect in the tubing system.

The determination and evaluation of any or all of the above conditions shall be according to the sole and exclusive discretion of CRC, and/or its authorized representative. If, upon examination, either CRC or its authorized representative determines that the defect or defects are caused by any of the above, the warranty obligation of CRC shall not be honored. No representative of CRC, other than an officer, has authority to change or extend these provisions or warranties. Changes or extensions shall be binding only if confirmed in writing by CRC's duly authorized executive officers. Product systems installed by CRC or its authorized representatives shall be or presumed to be properly installed and to be free of any and all conditions which might void the warranty at the time of installation. All product components or systems repaired or replaced are warranted under the same terms and conditions as the original Warranty, but only for the remaining time under the original warranty. No action shall be brought for any breach of this warranty more than one (1) year after the cause of action for such breach arises. Nothing herein shall be construed to extend any warranty beyond the stated periods. CRC shall not be liable for any default or delay in performance by it in accordance with these warranties which delay or performance is caused by contingency beyond its control including but not limited to war, government restriction or restraint, strikes, fire, floods, unavailability of raw material, and acts of God.

This Page Intentionally Left Blank

In storage areas where stacking of materials may occur, the installer must provide signs that specify the maximum stacking height so as to maintain the required clearance to combustibles. The following is a temporary sign that can be used until a permanent label is obtained from your representative or Combustion Research Corporation - Request P/N 5566.006. Attach this label near the *Reflect-O-Ray®* heater or by the thermostat.

	<p>COMBUSTION RESEARCH CORP.</p> <hr style="border: 2px solid red;"/> <p>Infrared Heating Systems</p>		
<p>⚠ WARNING</p>			
	<p>Fire Hazard</p> <p>Some objects can catch fire or explode when placed close to the heater.</p> <p>Keep all flammable objects, liquids and vapors the required clearance to combustibles away from the heater.</p> <p>Failure to follow these instructions can result in death, injury or property damage.</p>		
<p>Maintain _____ clearance</p> <p>to the side and</p> <p>_____ clearance below the</p> <p>heater from vehicles and</p> <p>combustible materials.</p>			
<p>Read and understand the Installation, Operation and Maintenance manual before installation, operation or service.</p> <p>Know your heater part number, and BTU input. The Part Number and BTU Input and clearance to combustible information can be found on the burner assembly and in the Installation, Operation and Maintenance manual.</p> <p>Write the largest clearance dimensions with permanent marker, according to the heater used, in the open spaces above.</p>			
<p>Combustion Research Corp. - 2516 Leach Rd. - Rochester Hills, MI 48309-3555 Telephone: 248.852.3611 Fax: 248.852.9165 www.combustionresearch.com</p>			
<p>Printed in U.S.A</p>	<p>Revision Date:</p>	<p>Rev. 0</p>	<p>P/N 5566.006</p>

