

COMBUSTION RESEARCH CORPORATION

FOR YOUR SAFETY

If you smell gas:

1. Open windows
2. **DO NOT** try to light any appliance.
3. **DO NOT** use electrical switches.
4. **DO NOT** use any telephone in your building.
5. Leave the building
6. Immediately call your local gas supplier after leaving the building. Follow gas supplier's instructions.
7. If you cannot reach your gas supplier, call the fire department.

⚠ WARNING



Fire Hazard

Do not store or use gasoline or other flammable vapors and liquids in the vicinity of this or any other appliance.

Some objects will catch fire or explode when placed near this heater.

Failure to follow these instructions can result in death, injury or property damage.

Omega II®

DUAL INPUT, Pre Engineered Systems

Gas Fired, Low Intensity Infrared Unitary Heating Systems

Installation, Operating, Maintenance and Parts Manual

⚠ WARNING

This equipment, its related accessories and by-products of operation, contain chemicals (including carbon monoxide) known to the State of California to cause cancer, birth defects, or other reproductive harm. **For more information go to www.P65Warnings.ca.gov**



Read and understand these installation, operating and maintenance instructions thoroughly before installing or servicing this equipment. Only trained, qualified gas installation and service personnel may install or service this equipment.

Installer

Please take time to read and understand these instructions prior to any installation. Installer must give a copy of this manual to the owner.

Owner

Keep this manual in a safe place in order to provide your serviceman with the necessary information.

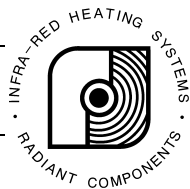

Combustion Research Corp.
2516 Leach Rd.
Rochester Hills, MI 48309-3555
Telephone: 248.852.3611
Fax: 248.852.9165

www.combustionresearch.com



! WARNING



FIRE OR EXPLOSION HAZARD

Can cause death, severe injury and/or property damage.

1. Read this manual carefully before installing or servicing this equipment. Improper installation, service or maintenance can cause death, injury and/or property damage.
2. Check clearances given on the outside of each burner to make sure the product is suitable for your application.
3. Installer must be a trained, experienced service technician.
4. All service must be performed only by a trained service technician or representative.
5. After installation is complete, check system operation as provided in these instructions.

Combustibles: Failure to maintain the specified minimum clearances to combustibles could result in a serious fire hazard. Do not locate flammable or combustible materials within this distance. Signs must be posted near thermostat and in storage areas to specify maximum stacking height to maintain required clearances to combustibles. Do not locate in hazardous atmospheres containing flammable vapors or combustible dust.

United States: Installations in public garages or airplane hangars are permitted when in accordance with NFPA-88 (latest edition) and NFPA-409 (latest edition) Codes.

Canada: Installation in public garages and airplane hangars is permitted when in accordance with CAN/CGA B.149.1 & CAN/CGA B149.2.

Vehicles: Minimum clearances must be maintained from vehicles parked, below the heater. Ensure that adequate clearance is maintained where vehicles are in operation or being serviced.

Gas Connection: There is an expansion of the radiant pipe with each firing cycle, and this will cause the burner to move with respect to the gas line. This can cause a gas leak resulting in an unsafe condition, if the gas connection is not made strictly in accordance with page 26 of these instructions.

Ignition: This appliance does not have a pilot. It is equipped with an ignition device, which automatically lights the burner. Do not try to light the burner by hand.

Mechanical Hazard – Blower Assembly: High speed rotating blower impeller/wheel can cause severe injury. Do not operate the blower without the blower wheel or inlet screen. Loose clothing can be drawn into unguarded inlet and entangle with blower wheel. Keep hands and fingers away from inlet and outlet.

Mechanical Hazard - Suspension: Use appropriate suspension hardware, beam clamps (rod or perforated strap) and turnbuckles at predetermined locations. The weight and normal movement of the heating system may cause support failure if the following minimum suspension requirements are not met: Distance between combination hangers must be 10-ft. (3 M) or less; chain size must be 3/0 minimum or equivalent.

NOTICE

Failure to follow these instructions can cause personal injury or property damage:

Caution must be used when running the system near combustible materials such as wood, paper, rubber, etc. Consideration should be given to partitions, storage racks, hoists, building construction, etc. Pages 5 thru 10 outlines minimum acceptable clearances to combustibles.

If the building has a slight negative pressure or contaminants are present in the air, an outside combustion air supply to the heaters is strongly recommended.

Do not use in an atmosphere containing halogenated hydrocarbons or other corrosive chemicals. Some compounds in the air can be drawn into the equipment and can cause an accelerated rate of corrosion of some parts of the radiant heat exchanger. The use of such chemical compounds in or near the enclosure should be avoided where a longer life of the burner, tubing and other parts is desirable.

! CAUTION

Failure to follow these instructions can cause damage to the system components:

DO NOT high-pressure test the gas piping with the burners connected. Failure to follow this procedure will exceed the pressure rating of burner gas controls and this will **require complete replacement of these parts.**

DO NOT operate a blower with an unrestricted inlet or outlet. An unrestricted airflow can overload the motor, which can cause motor or failure.

This heater is designed for heating nonresidential indoor spaces. These instructions, the layout drawing, local codes and ordinances, and applicable standards that apply to gas piping, electrical wiring, venting, etc. must be thoroughly understood before proceeding with the installation.

INSTALLER

PLEASE TAKE TIME TO READ AND UNDERSTAND THESE INSTRUCTIONS PRIOR TO ANY INSTALLATION. Contact your representative or the factory if you have any questions

OWNER

Retain this manual in a safe place to provide your serviceman with information if the situation arises.

TABLE OF CONTENTS

	PAGE(S)
Heater Safety & Burner Label Placement	1 & 2
Warning Symbols	3
Standards, Certifications and Codes	3 & 4
Installer Qualifications & Responsibility	4
Clearance to Combustibles	5 - 8
Assembly – Tube and Reflectors	9 - 14
System Dimensions & Turbulator Lengths	15
System Mounting Guidelines	16
Suspension Methods	17
Combustion Tube Installation	18
Customizing System	18
Side Shield Installation	19
Decorative Grille Installation	20
Seismic Restraint Suspension	21 & 22
Burner Connection & Installation	23
Gas Supply	24
Flexible Gas Connector Installation	25
Technical Data	26 & 27
Combustion Air	28 & 29
Venting	30 – 33
Electrical Information	34
Internal Wiring Diagram	35
Thermostat Wiring	36 & 37
System Start-Up	38 – 39
Sequence of Operation	39
Service & Maintenance	40 – 43
Trouble Shooting Flow Chart	44 – 46
Burner Parts List	47
Accessories & Optional Equipment	48 – 50
Warranty Statement and Terms and Conditions	51 & 52
Sample Clearance to Combustible Warning Sign	54

Omega II® heating systems DO NOT qualify for use in explosion proof installations. Heaters SHALL NOT be used in living/sleeping areas.

©2025 COMBUSTION RESEARCH CORPORATION, INC.

All rights reserved. No part of this work covered by the copyrights hereon in may be reproduced or copied in any form or by any means - graphic, electronic, or mechanical, including photocopying, recording, taping, or information storage and retrieval systems - without written permission of COMBUSTION RESEARCH CORPORATION, Inc.

This Page Intentionally Left Blank

HEATER SAFETY



Please take time to familiarize yourself with this manual as your safety is important to us. This symbol is used throughout this manual to notify you of possible fire, electrical, burn hazards or other safety issues. Pay special attention when reading this manual and follow the warnings.

Read this manual carefully before installation, operation, or service of this equipment.

Protective gear (including safety glasses) is to be worn during installation, set up and service. Sheet metal components, including the aluminum reflectors and field cut radiant tubes used on this system as well as various venting components have sharp edges. The use of gloves

will also help in reducing the transfer of dirt and oils to the surface of the reflectors.

If additional Installation, Operation and Service Manuals are needed, contact your Combustion Research Corporation independent representative or Combustion Research Corporation. The IOM's can also be found at www.combustionresearch.com.

To help prevent personal injury and damage to the heater components, at least two people will be required for installation.

SAFETY LABELS AND THEIR LOCATION

Product safety signs or labels should be replaced by the end user or servicing contractor when they are no longer legible or have been damaged. Please contact Combustion Research Corp. or your Combustion Research Corp. independent representative to obtain labels or signs.

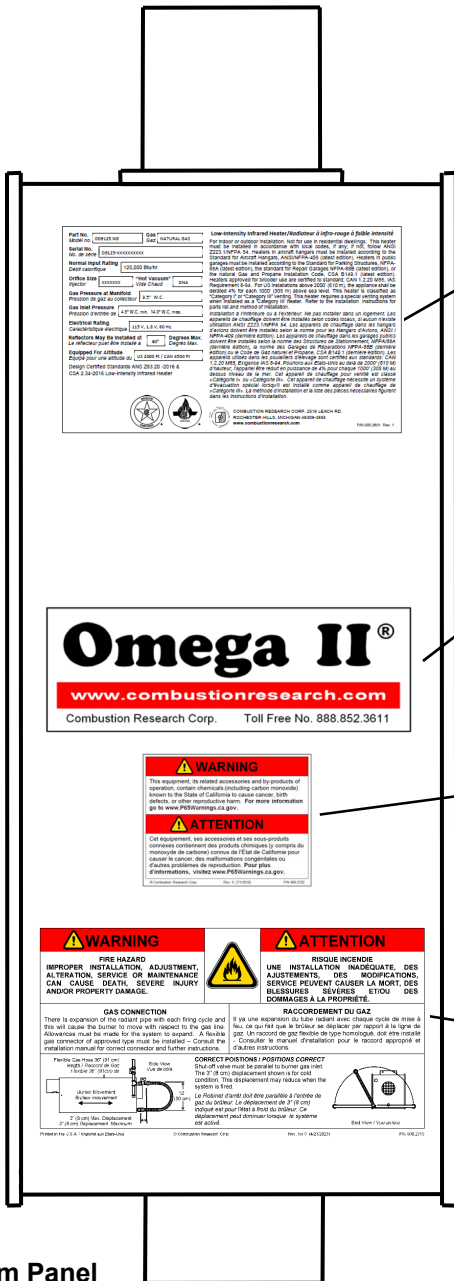

Part No. / Model No. / No. de série: 004123-010 / 004123-010 / 004123-010	Gas: NATURAL GAS	Low-Intensity Infrared Heater / Radiateur à infra-rouge à faible intensité
Normal Input Rating: 125,000 Btu/hr	Hot Vacuum: 0.15 in. Hg	For indoor or outdoor installation. Not for use in residential dwellings. This heater must be installed in accordance with local codes, if any, if not, follow ANSI Z223.1/NFPA 54. Heaters in aircraft hangars must be installed according to the standard for Aircraft Hangars, ANSI/NFPA-402 (latest edition), unless it meets the requirements for installation according to the standard for Parking Structures, NFPA-409 (latest edition), the standard for Repair Garages, NFPA-408 (latest edition), or the natural Gas and Propane Installation Code, CSA B149.1 (latest edition). Heaters approved for broader use are certified to standards: CAN 1.2.20.101, IAC Requirement 9-94. For US installations above 2000' (610 m), the appliance shall be certified 4th for each 1000' (305 m) above sea level. This heater is classified as "Category IV" or "Category III" venting. This heater requires a special venting system when installed as a Category III heater. Refer to the installation instructions for parts list and method of installation.
Gas Pressure at Manifold / Pression de gaz au collecteur: 3.5" W.C.	Gas Inlet Pressure / Pression d'entrée de gaz: 4.5" W.C. min. 14.0" W.C. max.	Installation à l'intérieur ou à l'extérieur. Ne pas installer dans un logement. Les appareils de chauffage doivent être installés selon codes locaux, si aucun n'existe utiliser ANSI Z223.1/NFPA 54. Les appareils de chauffage dans les hangars d'avions doivent être installés selon le norme pour les Hangars d'Avions, ANSI / NFPA-402 (dernière édition). Les appareils de chauffage dans les ateliers d'entretien doivent être installés selon la norme des Structures de Stationnement, NFPA-408 (dernière édition) ou le Code de Gaz Naturel et Propane, CSA B149.1 (dernière édition) ou le Code de Gaz Naturel et Propane, CSA B149.1 (dernière édition). Les chauffeuses approuvées pour une utilisation plus large sont certifiées selon les normes: CAN 1.2.20.101, IAC Requirement 9-94. Pour les installations au-dessus de 2000' (610 m), l'appareil doit être certifié 4ème pour chaque 1000' (305 m) au-dessus du niveau de la mer. Cet appareil de chauffage nécessite un système d'évacuation spécial lorsqu'il est installé comme appareil de chauffage de catégorie III. La méthode d'installation et la liste des pièces nécessaires figurent dans les instructions d'installation.
Electrical Rating: 125 V, 15 A, 60 Hz	Equipped For Altitude / Adapté pour une altitude: 0 to 2000 ft / 0 to 610 m	COMBUSTION RESEARCH CORP. 2616 LEACH RD. ROCHESTER HILLS, MICHIGAN 48066-3656

Rating Plate Label
P/N 900.2601

Logo Label
P/N 900.2708

WARNING

This equipment, its related accessories and by-products of operation, contain chemicals (including carbon monoxide) known to the State of California to cause cancer, birth defects, or other reproductive harm. For more information go to www.P65warnings.ca.gov.

ATTENTION

Cet équipement, ses accessoires et ses sous-produits contiennent des produits chimiques (y compris du monoxyde de carbone) connus de l'État de Californie pour causer le cancer, des malformations congénitales ou d'autres problèmes de reproduction. Pour plus d'informations, visitez www.P65Warnings.ca.gov.

California Proposition
65 Label
P/N 900.2722

<p>WARNING</p> <p>FIRE HAZARD IMPROPER INSTALLATION, ADJUSTMENT, ALTERATION, SERVICE OR MAINTENANCE CAN CAUSE DEATH, SEVERE INJURY AND/OR PROPERTY DAMAGE.</p>	<p>ATTENTION</p> <p>RISQUE INCENDIE UNE INSTALLATION INADÉQUATE, DES AJUSTEMENTS, DES MODIFICATIONS, SERVICE PEUVENT CAUSER LA MORT, DES BLESSURES SÉVÈRES ET/OU DES DOMMAGES À LA PROPRIÉTÉ.</p>
<p>GAS CONNECTION</p> <p>There is expansion of the radiant pipe with each firing cycle and this will cause the burner to move with respect to the gas line. Allowances must be made for the system to expand. A flexible gas connector of approved type must be installed. Consult the installation manual for correct connector and further instructions.</p>	<p>RACCORDEMENT DU GAZ</p> <p>Il y a une expansion du tube radiant avec chaque cycle de mise à feu, ce qui fait que le brûleur se déplace par rapport à la ligne de gaz. Un raccordeur de gaz type non rigide, ou, autre instance - Consulter le manuel d'installation pour le raccordeur approprié et d'autres instructions.</p>
<p>Flexible Gas Hose: 3/8" (9.5 mm) length / Raccordeur de gaz flexible: 3/8" (9.5 mm) de longueur</p> <p>Side View / Vue latérale</p> <p>3" (8 cm) Max. Displacement / 3" (8 cm) Déplacement Maximum</p>	<p>CORRECT POSITIONS / POSITIONS CORRECT</p> <p>Shut-off valve must be parallel to burner gas inlet. The 3" (8 cm) displacement shown is for cold condition. This displacement may reduce when the system is fired.</p> <p>Le Robinet d'arrêt doit être parallèle à l'entrée de gaz du brûleur. Le déplacement de 3" (8 cm) indiqué est pour l'état à froid du brûleur. Ce déplacement peut diminuer lorsque le système est activé.</p> <p>End View / Vue arrière</p>

Gas Connector Label
P/N 900.2715

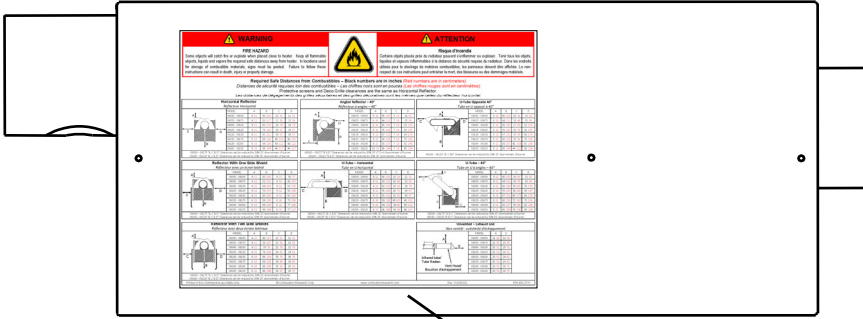

Side Cover Panel (Control Side)

WARNING		ATTENTION																																											
<p>FIRE HAZARD</p> <p>Some liquids will catch fire or explode when placed close to heater. Keep all flammable liquids, vapors and gases the required safe distance away from heater. In locations with air dilution or entrainment, vapors must be tested. Failure to follow these instructions can result in death, injury or property damage.</p>		<p>Risque d'incendie</p> <p>Certains liquides sont susceptibles de s'enflammer ou d'exploser. Tenir les liquides inflammables et les vapeurs inflammables à la distance de sécurité requise du radiateur. Dans les endroits où il y a dilution ou entraînement des vapeurs, ces derniers doivent être testés. Le non-respect de ces instructions peut entraîner la mort, des blessures ou des dommages matériels.</p>																																											
<p>Required Safe Distances from Combustibles - Black numbers are in inches (Red numbers are in centimeters) Distances de sécurité requises par rapport aux combustibles - Les chiffres noirs sont en pouces (Les chiffres rouges sont en centimètres)</p> <p>Les distances de séparation requises des combustibles sont les mêmes que celles du réflecteur horizontal.</p>																																													
<p>Horizontal Reflector Réflecteur horizontal</p> <table border="1"> <tr> <th>Angle</th> <th>15°</th> <th>30°</th> <th>45°</th> <th>60°</th> <th>75°</th> <th>90°</th> </tr> <tr> <td>Clearance</td> <td>18"</td> <td>24"</td> <td>30"</td> <td>36"</td> <td>42"</td> <td>48"</td> </tr> <tr> <td>Clearance</td> <td>46 cm</td> <td>61 cm</td> <td>76 cm</td> <td>91 cm</td> <td>107 cm</td> <td>122 cm</td> </tr> </table>		Angle	15°	30°	45°	60°	75°	90°	Clearance	18"	24"	30"	36"	42"	48"	Clearance	46 cm	61 cm	76 cm	91 cm	107 cm	122 cm	<p>Angle Reflector - 45° Réflecteur à angle 45°</p> <table border="1"> <tr> <th>Angle</th> <th>15°</th> <th>30°</th> <th>45°</th> <th>60°</th> <th>75°</th> <th>90°</th> </tr> <tr> <td>Clearance</td> <td>18"</td> <td>24"</td> <td>30"</td> <td>36"</td> <td>42"</td> <td>48"</td> </tr> <tr> <td>Clearance</td> <td>46 cm</td> <td>61 cm</td> <td>76 cm</td> <td>91 cm</td> <td>107 cm</td> <td>122 cm</td> </tr> </table>		Angle	15°	30°	45°	60°	75°	90°	Clearance	18"	24"	30"	36"	42"	48"	Clearance	46 cm	61 cm	76 cm	91 cm	107 cm	122 cm
Angle	15°	30°	45°	60°	75°	90°																																							
Clearance	18"	24"	30"	36"	42"	48"																																							
Clearance	46 cm	61 cm	76 cm	91 cm	107 cm	122 cm																																							
Angle	15°	30°	45°	60°	75°	90°																																							
Clearance	18"	24"	30"	36"	42"	48"																																							
Clearance	46 cm	61 cm	76 cm	91 cm	107 cm	122 cm																																							
<p>Reflector With One Side Shield</p> <table border="1"> <tr> <th>Angle</th> <th>15°</th> <th>30°</th> <th>45°</th> <th>60°</th> <th>75°</th> <th>90°</th> </tr> <tr> <td>Clearance</td> <td>18"</td> <td>24"</td> <td>30"</td> <td>36"</td> <td>42"</td> <td>48"</td> </tr> <tr> <td>Clearance</td> <td>46 cm</td> <td>61 cm</td> <td>76 cm</td> <td>91 cm</td> <td>107 cm</td> <td>122 cm</td> </tr> </table>		Angle	15°	30°	45°	60°	75°	90°	Clearance	18"	24"	30"	36"	42"	48"	Clearance	46 cm	61 cm	76 cm	91 cm	107 cm	122 cm	<p>90° Reflector - Horizontal</p> <table border="1"> <tr> <th>Angle</th> <th>15°</th> <th>30°</th> <th>45°</th> <th>60°</th> <th>75°</th> <th>90°</th> </tr> <tr> <td>Clearance</td> <td>18"</td> <td>24"</td> <td>30"</td> <td>36"</td> <td>42"</td> <td>48"</td> </tr> <tr> <td>Clearance</td> <td>46 cm</td> <td>61 cm</td> <td>76 cm</td> <td>91 cm</td> <td>107 cm</td> <td>122 cm</td> </tr> </table>		Angle	15°	30°	45°	60°	75°	90°	Clearance	18"	24"	30"	36"	42"	48"	Clearance	46 cm	61 cm	76 cm	91 cm	107 cm	122 cm
Angle	15°	30°	45°	60°	75°	90°																																							
Clearance	18"	24"	30"	36"	42"	48"																																							
Clearance	46 cm	61 cm	76 cm	91 cm	107 cm	122 cm																																							
Angle	15°	30°	45°	60°	75°	90°																																							
Clearance	18"	24"	30"	36"	42"	48"																																							
Clearance	46 cm	61 cm	76 cm	91 cm	107 cm	122 cm																																							
<p>Reflector With Two Side Shields</p> <table border="1"> <tr> <th>Angle</th> <th>15°</th> <th>30°</th> <th>45°</th> <th>60°</th> <th>75°</th> <th>90°</th> </tr> <tr> <td>Clearance</td> <td>18"</td> <td>24"</td> <td>30"</td> <td>36"</td> <td>42"</td> <td>48"</td> </tr> <tr> <td>Clearance</td> <td>46 cm</td> <td>61 cm</td> <td>76 cm</td> <td>91 cm</td> <td>107 cm</td> <td>122 cm</td> </tr> </table>		Angle	15°	30°	45°	60°	75°	90°	Clearance	18"	24"	30"	36"	42"	48"	Clearance	46 cm	61 cm	76 cm	91 cm	107 cm	122 cm	<p>90° Reflector - 45°</p> <table border="1"> <tr> <th>Angle</th> <th>15°</th> <th>30°</th> <th>45°</th> <th>60°</th> <th>75°</th> <th>90°</th> </tr> <tr> <td>Clearance</td> <td>18"</td> <td>24"</td> <td>30"</td> <td>36"</td> <td>42"</td> <td>48"</td> </tr> <tr> <td>Clearance</td> <td>46 cm</td> <td>61 cm</td> <td>76 cm</td> <td>91 cm</td> <td>107 cm</td> <td>122 cm</td> </tr> </table>		Angle	15°	30°	45°	60°	75°	90°	Clearance	18"	24"	30"	36"	42"	48"	Clearance	46 cm	61 cm	76 cm	91 cm	107 cm	122 cm
Angle	15°	30°	45°	60°	75°	90°																																							
Clearance	18"	24"	30"	36"	42"	48"																																							
Clearance	46 cm	61 cm	76 cm	91 cm	107 cm	122 cm																																							
Angle	15°	30°	45°	60°	75°	90°																																							
Clearance	18"	24"	30"	36"	42"	48"																																							
Clearance	46 cm	61 cm	76 cm	91 cm	107 cm	122 cm																																							
<p>Vertical Reflector</p> <table border="1"> <tr> <th>Angle</th> <th>15°</th> <th>30°</th> <th>45°</th> <th>60°</th> <th>75°</th> <th>90°</th> </tr> <tr> <td>Clearance</td> <td>18"</td> <td>24"</td> <td>30"</td> <td>36"</td> <td>42"</td> <td>48"</td> </tr> <tr> <td>Clearance</td> <td>46 cm</td> <td>61 cm</td> <td>76 cm</td> <td>91 cm</td> <td>107 cm</td> <td>122 cm</td> </tr> </table>		Angle	15°	30°	45°	60°	75°	90°	Clearance	18"	24"	30"	36"	42"	48"	Clearance	46 cm	61 cm	76 cm	91 cm	107 cm	122 cm	<p>Vertical Reflector - 45°</p> <table border="1"> <tr> <th>Angle</th> <th>15°</th> <th>30°</th> <th>45°</th> <th>60°</th> <th>75°</th> <th>90°</th> </tr> <tr> <td>Clearance</td> <td>18"</td> <td>24"</td> <td>30"</td> <td>36"</td> <td>42"</td> <td>48"</td> </tr> <tr> <td>Clearance</td> <td>46 cm</td> <td>61 cm</td> <td>76 cm</td> <td>91 cm</td> <td>107 cm</td> <td>122 cm</td> </tr> </table>		Angle	15°	30°	45°	60°	75°	90°	Clearance	18"	24"	30"	36"	42"	48"	Clearance	46 cm	61 cm	76 cm	91 cm	107 cm	122 cm
Angle	15°	30°	45°	60°	75°	90°																																							
Clearance	18"	24"	30"	36"	42"	48"																																							
Clearance	46 cm	61 cm	76 cm	91 cm	107 cm	122 cm																																							
Angle	15°	30°	45°	60°	75°	90°																																							
Clearance	18"	24"	30"	36"	42"	48"																																							
Clearance	46 cm	61 cm	76 cm	91 cm	107 cm	122 cm																																							

Clearance to Combustibles Label
P/N 900.2731

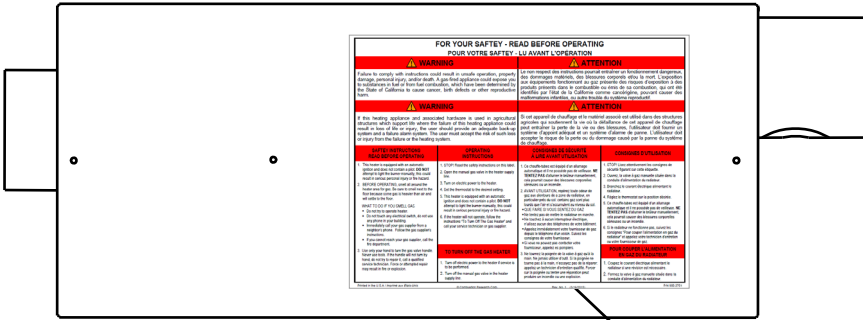

Side Cover Panel

FOR YOUR SAFETY - READ BEFORE OPERATING			
POUR VOTRE SÉCURITÉ - LU AVANT L'OPÉRATION			
<p>WARNING</p> <p>Failure to comply with instructions could result in unsafe operation, property damage, personal injury, and/or death. A gas-fired appliance could expose you to substances in fuel or from fuel combustion, which have been identified by the State of California to cause cancer, birth defects or other reproductive harm.</p>		<p>ATTENTION</p> <p>Le non-respect des instructions pourrait entraîner un fonctionnement dangereux, des dommages matériels, des blessures corporelles et/ou la mort. L'exposition aux équipements fonctionnant au gaz présente des risques d'exposition à des produits présents dans le combustible ou émis de sa combustion, qui ont été classifiés par l'état de la Californie comme cancérigènes, pouvant causer des malformations infantiles ou autre trouble du système reproductif.</p>	
<p>WARNING</p> <p>If this heating appliance and associated hardware is used in agricultural structures which support life where the failure of this heating appliance could result in loss of life or injury, the user should provide an adequate back-up system and a failure alarm system. The user must accept the risk of such loss or injury from the failure of the heating system.</p>		<p>ATTENTION</p> <p>Si cet appareil de chauffage et le matériel associé est utilisé dans des structures agricoles qui supportent la vie où la défaillance de cet appareil de chauffage peut entraîner la perte de la vie ou des blessures, l'utilisateur doit fournir un système d'appoint adéquat et un système d'alarme de panne. L'utilisateur doit accepter le risque de la perte ou du dommage causé par la panne du système de chauffage.</p>	
<p>SAFETY INSTRUCTIONS</p> <p>1. This heater is equipped with an automatic ignition and does not contain a pilot. DO NOT attempt to light the burner manually. This could result in serious personal injury or fire hazard.</p> <p>2. BEFORE OPERATING, check to assure the heater area is gas. Be sure to read and read the floor because some gas is heavier than air and will settle in the floor.</p> <p>WHAT TO DO IF YOU SMELL GAS</p> <ul style="list-style-type: none"> Do not try to operate heater. Do not touch any electrical switch, do not use any phone or any electrical equipment. Immediately call your gas supplier from a neighbor's phone. Follow the gas supplier's instructions. If you cannot reach your gas supplier, call the fire department. 	<p>OPERATING INSTRUCTIONS</p> <p>1. L'ETCPI possède les instructions de sécurité sur ce produit.</p> <p>2. Avant de passer à l'électricité, vérifiez que l'air est libre de gaz.</p> <p>3. Avant d'utiliser l'appareil, vérifiez que l'air est libre de gaz.</p> <p>4. Ce chauffe-bain est équipé d'un allumage automatique et ne contient pas de brûleur. NE tentez pas d'allumer le brûleur manuellement. Cela pourrait causer des blessures corporelles et/ou la mort.</p> <p>5. Avant d'utiliser l'appareil, vérifiez que l'air est libre de gaz.</p> <p>6. Avant d'utiliser l'appareil, vérifiez que l'air est libre de gaz.</p>	<p>CONDITIONS DE SÉCURITÉ À LIRE AVANT L'UTILISATION</p> <p>1. L'ETCPI possède les instructions de sécurité de cet appareil. Ne tentez pas d'allumer le brûleur manuellement. Cela pourrait causer des blessures corporelles et/ou la mort.</p> <p>2. Avant d'utiliser l'appareil, vérifiez que l'air est libre de gaz.</p> <p>3. Avant d'utiliser l'appareil, vérifiez que l'air est libre de gaz.</p> <p>4. Ce chauffe-bain est équipé d'un allumage automatique et ne contient pas de brûleur. NE tentez pas d'allumer le brûleur manuellement. Cela pourrait causer des blessures corporelles et/ou la mort.</p> <p>5. Avant d'utiliser l'appareil, vérifiez que l'air est libre de gaz.</p> <p>6. Avant d'utiliser l'appareil, vérifiez que l'air est libre de gaz.</p>	<p>CONDITIONS D'UTILISATION</p> <p>1. L'ETCPI possède les instructions de sécurité de cet appareil. Ne tentez pas d'allumer le brûleur manuellement. Cela pourrait causer des blessures corporelles et/ou la mort.</p> <p>2. Avant d'utiliser l'appareil, vérifiez que l'air est libre de gaz.</p> <p>3. Avant d'utiliser l'appareil, vérifiez que l'air est libre de gaz.</p> <p>4. Ce chauffe-bain est équipé d'un allumage automatique et ne contient pas de brûleur. NE tentez pas d'allumer le brûleur manuellement. Cela pourrait causer des blessures corporelles et/ou la mort.</p> <p>5. Avant d'utiliser l'appareil, vérifiez que l'air est libre de gaz.</p> <p>6. Avant d'utiliser l'appareil, vérifiez que l'air est libre de gaz.</p>
<p>TO TURN OFF THE GAS HEATER</p> <p>1. Turn off electric power to the heater if a fault is to be repaired.</p> <p>2. Turn off the manual gas valve in the heater supply line.</p>		<p>À DÉMARRER LE CHAUFFAGE AU GAZ</p> <p>1. Coupez le courant électrique alimentant le radiateur si une réparation est nécessaire.</p> <p>2. Fermez le valve à gaz manuelle située dans la conduite d'alimentation du radiateur.</p>	

FOR YOUR SAFETY - READ BEFORE OPERATING			
POUR VOTRE SÉCURITÉ - LU AVANT L'OPÉRATION			
<p>WARNING</p> <p>Failure to comply with instructions could result in unsafe operation, property damage, personal injury, and/or death. A gas-fired appliance could expose you to substances in fuel or from fuel combustion, which have been identified by the State of California to cause cancer, birth defects or other reproductive harm.</p>		<p>ATTENTION</p> <p>Le non-respect des instructions pourrait entraîner un fonctionnement dangereux, des dommages matériels, des blessures corporelles et/ou la mort. L'exposition aux équipements fonctionnant au gaz présente des risques d'exposition à des produits présents dans le combustible ou émis de sa combustion, qui ont été classifiés par l'état de la Californie comme cancérigènes, pouvant causer des malformations infantiles ou autre trouble du système reproductif.</p>	
<p>WARNING</p> <p>If this heating appliance and associated hardware is used in agricultural structures which support life where the failure of this heating appliance could result in loss of life or injury, the user should provide an adequate back-up system and a failure alarm system. The user must accept the risk of such loss or injury from the failure of the heating system.</p>		<p>ATTENTION</p> <p>Si cet appareil de chauffage et le matériel associé est utilisé dans des structures agricoles qui supportent la vie où la défaillance de cet appareil de chauffage peut entraîner la perte de la vie ou des blessures, l'utilisateur doit fournir un système d'appoint adéquat et un système d'alarme de panne. L'utilisateur doit accepter le risque de la perte ou du dommage causé par la panne du système de chauffage.</p>	
<p>SAFETY INSTRUCTIONS</p> <p>1. This heater is equipped with an automatic ignition and does not contain a pilot. DO NOT attempt to light the burner manually. This could result in serious personal injury or fire hazard.</p> <p>2. BEFORE OPERATING, check to assure the heater area is gas. Be sure to read and read the floor because some gas is heavier than air and will settle in the floor.</p> <p>WHAT TO DO IF YOU SMELL GAS</p> <ul style="list-style-type: none"> Do not try to operate heater. Do not touch any electrical switch, do not use any phone or any electrical equipment. Immediately call your gas supplier from a neighbor's phone. Follow the gas supplier's instructions. If you cannot reach your gas supplier, call the fire department. 	<p>OPERATING INSTRUCTIONS</p> <p>1. L'ETCPI possède les instructions de sécurité sur ce produit.</p> <p>2. Avant de passer à l'électricité, vérifiez que l'air est libre de gaz.</p> <p>3. Avant d'utiliser l'appareil, vérifiez que l'air est libre de gaz.</p> <p>4. Ce chauffe-bain est équipé d'un allumage automatique et ne contient pas de brûleur. NE tentez pas d'allumer le brûleur manuellement. Cela pourrait causer des blessures corporelles et/ou la mort.</p> <p>5. Avant d'utiliser l'appareil, vérifiez que l'air est libre de gaz.</p> <p>6. Avant d'utiliser l'appareil, vérifiez que l'air est libre de gaz.</p>	<p>CONDITIONS DE SÉCURITÉ À LIRE AVANT L'UTILISATION</p> <p>1. L'ETCPI possède les instructions de sécurité de cet appareil. Ne tentez pas d'allumer le brûleur manuellement. Cela pourrait causer des blessures corporelles et/ou la mort.</p> <p>2. Avant d'utiliser l'appareil, vérifiez que l'air est libre de gaz.</p> <p>3. Avant d'utiliser l'appareil, vérifiez que l'air est libre de gaz.</p> <p>4. Ce chauffe-bain est équipé d'un allumage automatique et ne contient pas de brûleur. NE tentez pas d'allumer le brûleur manuellement. Cela pourrait causer des blessures corporelles et/ou la mort.</p> <p>5. Avant d'utiliser l'appareil, vérifiez que l'air est libre de gaz.</p> <p>6. Avant d'utiliser l'appareil, vérifiez que l'air est libre de gaz.</p>	<p>CONDITIONS D'UTILISATION</p> <p>1. L'ETCPI possède les instructions de sécurité de cet appareil. Ne tentez pas d'allumer le brûleur manuellement. Cela pourrait causer des blessures corporelles et/ou la mort.</p> <p>2. Avant d'utiliser l'appareil, vérifiez que l'air est libre de gaz.</p> <p>3. Avant d'utiliser l'appareil, vérifiez que l'air est libre de gaz.</p> <p>4. Ce chauffe-bain est équipé d'un allumage automatique et ne contient pas de brûleur. NE tentez pas d'allumer le brûleur manuellement. Cela pourrait causer des blessures corporelles et/ou la mort.</p> <p>5. Avant d'utiliser l'appareil, vérifiez que l'air est libre de gaz.</p> <p>6. Avant d'utiliser l'appareil, vérifiez que l'air est libre de gaz.</p>
<p>TO TURN OFF THE GAS HEATER</p> <p>1. Turn off electric power to the heater if a fault is to be repaired.</p> <p>2. Turn off the manual gas valve in the heater supply line.</p>		<p>À DÉMARRER LE CHAUFFAGE AU GAZ</p> <p>1. Coupez le courant électrique alimentant le radiateur si une réparation est nécessaire.</p> <p>2. Fermez le valve à gaz manuelle située dans la conduite d'alimentation du radiateur.</p>	

Operating Instructions Label
P/N 900.2701

WARNING SYMBOLS



Warning indicates a potentially hazardous situation which, if not avoided, could result in death or injury.



Caution indicates a potentially hazardous situation which, if not avoided, could result in minor or moderate injury.



Notice indicates a potentially hazardous situation which, if not avoided, could result in property damage.

CHECKING SHIPMENT

Upon receipt of shipment, check shipment against Bill of Lading for shortages. Also check for external damage to cartons or tube bundles. Shortages and/or external damage to cartons or tubes must be noted on the Bill of Lading in the presence of delivery trucker. The delivery trucker should acknowledge any shortages or damage by initialing this "noted" Bill of Lading.

Claims for damaged material, or shortages that were not evident upon receipt of shipment must be reported to carrier and Combustion Research Corporation Sales Representatives within 72 hours.

Before starting to assemble the heater, make sure that all optional and accessory items are accounted for and are available for assembly. It is also important to verify that the correct gas burner is supplied for the gas service, i.e., natural gas burner for natural gas supply.

IMPORTANT



IMPROPER INSTALLATION CAN CAUSE DEATH, SEVERE INJURY AND/OR PROPERTY DAMAGE.

Read and understand these installation, operating and maintenance instructions thoroughly before installing or servicing this equipment. Only trained, qualified gas installation and service personnel may install or service this equipment.

These instructions, the layout drawing, local codes and ordinances, and applicable standards, such that apply to gas piping and electrical wiring, must be thoroughly understood before proceeding with the installation.

TESTED UNDER STANDARDS

AMERICAN STANDARDS – Z83.20 (current standard)

CANADIAN STANDARDS – CSA 2.34 (current standard)

GAS FIRED BROODERS - IAS Requirement 8-94 &

CAN 1-2.20-M85

BUILDING CODES

In the absence of local codes, the installation must conform to the latest edition of:

United States: National Fuel Gas Code, ANSI Z223.1 (NFPA 54).

Canada: CAN/CGA B149.1 and .2, Canadian Electrical Code C22.1

AIRCRAFT HANGARS

Heaters for use in aircraft hangars must be installed in accordance with;

United States: Refer to Standard for Aircraft Hangars, ANSI/NFPA 409 (latest edition).

In Canada: Refer to Standard CAN/CGA B149.1 and B149.2 and applicable Standards for Aircraft Hangars.

Basic guidelines are as follows:

1. Suspended heaters in aircraft storage or service areas shall be installed at least ten feet (10') above the upper surface of wings or engine enclosures of the highest aircraft which may be housed in the hangar. This should be measured from the bottom of the heater to the wing or engine enclosure; whichever is highest from the floor.
2. In other sections of aircraft hangars, such as shops or offices communicating with airplane storage or servicing area, heaters shall be installed in accordance with their listings and mounted not less than eight feet (8') above the floor.
3. Heaters installed in aircraft hangars shall be located so as not to be subject to injury by aircraft, cranes, moveable scaffolding, or other objects. Provisions shall be made to ensure accessibility to suspended heaters for recurrent maintenance purposes.

PUBLIC GARAGES

Heaters for use in public garages must be installed in accordance with:

United States: Standard for Parking Structures NFPA 88A (latest edition) or the Code for Motor Fuel Dispensing Facilities and Repair Garages NFPA 30A (latest edition).

Canada: Refer to CAN/CGA B149.1 and B149.2: Installation Codes for Gas Burning Appliances and applicable Standards for Public Garages.:

Basic guidelines are as follows:

1. Heaters shall be installed in accordance with their listings and not be mounted less than eight feet (8') above the floor. Minimum clearances to combustibles must be maintained from vehicles parked below the heater.
2. When installed over hoists, clearance to combustible material must be maintained from upper most point of the hoist or provided as insulating or reflective barrier on the hoist (consult representative or factory for guidance).

ELECTRICAL GROUNDING

The burner unit must be electrically grounded in accordance with the following codes:

United States: Refer to National Electrical Code®, ANSI/NFPA 70 (latest edition). Wiring must conform to the latest edition of National Electrical Code®, local ordinances, and any special diagrams furnished.

Canada: Refer to Canadian Electrical Code CSA C22.1 Part 1 (latest edition).

GAS INPUT LINES

The method of pipe sizing must conform to the U.S. National Standards: ANSI Z223.1 (current standard) National Fuel Gas Code or CAN 1-B149.1 Installation Code and should be installed in accordance with all National and Local Codes and ordinances.

CLEARANCES AND ACCESSIBILITY

Inlet air assemblies are to be installed with the air opening pointing toward the ground to protect against rain and snow. Inlet is provided with a bird screen. Adequate clearance must be provided around the inlet air assembly opening to provide an unobstructed entry for the combustion air. Clearances must be sufficient to provide accessibility for servicing. The air inlets must be a minimum of six feet (6') from the exhaust port.

AGRICULTURAL INSTALLATIONS

In agricultural installations *Omega II*® heating systems must be installed as vented systems only.

HAZARDOUS LOCATIONS

Where there is the possibility of exposure to combustible airborne materials or vapor, consult the local Fire Marshal, the fire insurance carrier, or other authorities for approval of the proposed installation. ***Omega II*® heating systems DO NOT qualify for use in explosion proof installations.**

INSTALLER QUALIFICATIONS

Only firms or individuals qualified to perform work in accordance with the applicable specifications should be engaged to install a *Omega II*® system. Consult local Building Inspectors, Fire Marshals, or the local applicable Combustion Research Corporation representative for guidance.

INSTALLER RESPONSIBILITY

Omega II® systems are installed based on information given in a layout drawing. Together with these instructions and the cited codes and regulations comprise the information needed to complete the installation. The installer must furnish all needed material that is not furnished as standard *Omega II*® equipment, and it is his responsibility to see that such materials, as well as the installation methods he uses result in a job that is workman like and in keeping with all applicable codes.

In storage areas where stacking of materials may occur, the installer must provide signs that specify the

maximum stacking height to maintain the required clearance to combustibles. A temporary sample sign can be found at the end of this manual.

GENERAL CONSIDERATIONS

Combustion Research Corporation Factory Representatives are experienced in the application of this equipment and can be called on for suggestions about installation which can give the owner of the building a more satisfactory and economical installation.

When installing the *Omega II*® system, take maximum advantage of the building upper structure, beams, joists, purlins etc. from which to suspend the system. Mount units at minimum height for ease of installation and maintenance but of specified height to fully utilize the building.

The general layout of the *Omega II*® heating system has been established by the engineering drawing. The *Omega II*® heaters are used to heat building structures as well as localized areas that would include doors, loading docks and isolated workstations throughout the building. The location of the *Omega II*® heaters should be such that the area is covered uniformly, in that the heat is positioned on the perimeter or to each side of the area to be heated, rather than directly overhead. This will provide a better comfort condition for workers who would be in these areas. Consult with your representative or the factory for additional guidance in designing the optimum layout for your project.

Omega II® is a suspended system, which requires that consideration be given to the factors that determine its stability, flexibility, safety, and satisfactory operation. Before installation, the contractor should inspect the building along with the owner (or engineer) responsible for the building to check on the use of the building. Inspection of the building including the use of floor space for storage and height of materials stored in the building must be noted so that there are no problems with clearances to combustibles. Care should be taken over doors and high objects such as buses, trucks, cranes, car lifts, etc. Whenever possible use side wall penetrations for combustion air inlets to burners and exhaust venting.

DO -

- **Maintain specified clearances to combustibles, and to heat sensitive material, equipment, and workstations.**
- **Provide approved heat radiation shielding or barriers if needed. Refer to the National Fuel Gas Code for guidance.**
- **Provide access for general servicing; provide easy access for complete removal of burner assembly.**
- **Familiarize yourself with local and national codes.**
- **Develop a planned installation procedure, which will conserve material and labor on the job. Check to see that all material and equipment is on the job before starting installation. Be sure to accommodate thermal expansion of the hot tube.**
- **Use the gas connector ONLY as shown in the instructions.**
- **Provide end clearance tubing won't expand and touch a wall or structural member.**

CLEARANCE TO COMBUSTIBLES

⚠ WARNING



Placement of explosive objects, flammable objects, liquids, and vapors close to the heater may result in fire, explosion, death and serious injury or property damage. Do not store or use explosive objects, liquids, and vapor in the vicinity of the heater.

In all situations the clearance to combustibles must be maintained. Failure to observe clearances to combustibles may result in death, serious injury, or property damage. **In storage areas where stacking of materials may occur, the installer must provide signs, which specify the maximum stacking height to maintain the required clearance to combustibles.** Minimum clearances must be maintained from vehicles parked below the heater. Ensure that adequate clearance

is maintained where vehicles are in operation or being serviced. Consideration must be given when running the radiant tube next to wood, paper, storage racks, hoists, building construction, etc. For building personnel safety, the system shall not be mounted lower than 9' from the floor unless fitted with protective screens. The following illustrations and information give minimum acceptable clearance to combustibles. Use high fire BTU input when determining clearances.

Minimum clearances to combustibles must be maintained for wall, floor, ceiling. **The stated clearance to combustibles represents a surface temperature of 90°F (50°C) above room temperature. Building materials with a low heat tolerance (such as plastics, vinyl siding, canvas, triply, FRP board, etc.) may be subject to degradation at lower temperatures. It is the installer's responsibility to assure that adjacent materials are protected from degradation.**

Clearances must also be maintained from vehicles parked below as well as storage racks, partitions, hoists, building construction, sprinkler heads, etc.

In storage areas where stacking of materials may occur, the installer must provide signs that specify the maximum stacking height so that the required clearance to combustibles is maintained. A temporary sign can be found at the end of this manual. Contact your sales representative or Combustion Research Corporation for this self-adhesive label – P/N 5566.006.

Horizontal Reflector

MBH Input	A	B	C	D
30 - 50	4" (11 cm)	40" (102 cm)	12" (31 cm)	12" (31 cm)
55 - 75	4" (11 cm)	50" (127 cm)	22" (56 cm)	22" (56 cm)
80 - 100	4" (11 cm)	60" (153 cm)	29" (74 cm)	29" (74 cm)
105 - 125	4" (11 cm)	76" (193 cm)	34" (87 cm)	34" (87 cm)
130 - 150	4" (11 cm)	83" (211 cm)	38" (97 cm)	38" (97 cm)
155 - 175	6" (16 cm)	89" (226 cm)	40" (102 cm)	40" (102 cm)
180 - 200	8" (21 cm)	94" (239 cm)	44" (112 cm)	44" (112 cm)
205 - 220	9" (23 cm)	96" (244 cm)	46" (117 cm)	46" (117 cm)

30,000 – 175,000 "B, C & D" Clearances can be reduced by 50% 25' (7.5 m) downstream of burner
 180,000 – 220,000 "B, C & D" Clearances can be reduced by 50% 35' (10.7 m) downstream of burner

Angled Reflector - 40°

MBH Input	A	B	C	D
30 - 50	6" (16 cm)	40" (102 cm)	5" (13 cm)	32" (82 cm)
55 - 75	6" (16 cm)	44" (112 cm)	7" (18 cm)	35" (89 cm)
80 - 100	6" (16 cm)	66" (168 cm)	7" (18 cm)	53" (135 cm)
105 - 125	6" (16 cm)	76" (193 cm)	7" (18 cm)	58" (147 cm)
130 - 150	8" (21 cm)	87" (221 cm)	7" (18 cm)	69" (176 cm)
155 - 175	8" (21 cm)	90" (229 cm)	7" (18 cm)	75" (191 cm)
180 - 200	8" (21 cm)	93" (237 cm)	8" (21 cm)	84" (214 cm)
205 - 220	10" (26 cm)	96" (244 cm)	8" (21 cm)	88" (224 cm)

30,000 – 175,000 "B & D" Clearances can be reduced by 50% 25' (7.5 m) downstream of burner
 180,000 – 220,000 "B & D" Clearances can be reduced by 50% 35' (10.7 m) downstream of burner

One Side Shield Reflector

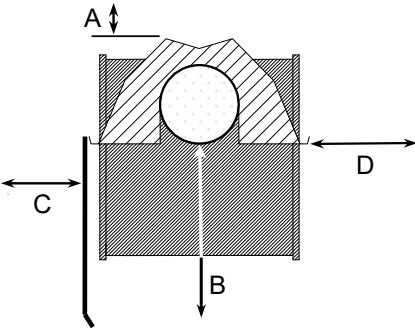
	MBH Input	A	B	C	D
	30 - 50	4" (11 cm)	43" (110 cm)	4" (11 cm)	30" (77 cm)
55 - 75	4" (11 cm)	52" (132 cm)	4" (11 cm)	42" (107 cm)	
80 - 100	4" (11 cm)	64" (163 cm)	4" (11 cm)	53" (135 cm)	
105 - 125	4" (11 cm)	70" (178 cm)	4" (11 cm)	55" (140 cm)	
130 - 150	4" (11 cm)	80" (204 cm)	4" (11 cm)	65" (166 cm)	
155 - 175	8" (21 cm)	89" (226 cm)	6" (16 cm)	73" (186 cm)	
180 - 200	8" (21 cm)	94" (239 cm)	8" (21 cm)	77" (196 cm)	
205 - 220	9" (23 cm)	96" (244 cm)	8" (21 cm)	77" (196 cm)	

30,000 – 175,000 "B & D" Clearances can be reduced by 50% 25' (7.5 m) downstream of burner
 180,000 – 220,000 "B & D" Clearances can be reduced by 50% 35' (10.7 m) downstream of burner

Two Side Shield Reflector

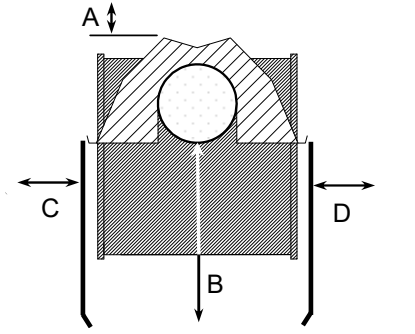
	MBH Input	A	B	C	D
	30 - 50	4" (11 cm)	46" (117 cm)	12" (31 cm)	12" (31 cm)
55 - 75	4" (11 cm)	58" (148 cm)	16" (41 cm)	16" (41 cm)	
80 - 100	4" (11 cm)	70" (178 cm)	22" (56 cm)	22" (56 cm)	
105 - 125	4" (11 cm)	78" (199 cm)	24" (61 cm)	24" (61 cm)	
130 - 150	4" (11 cm)	86" (219 cm)	30" (77 cm)	30" (77 cm)	
155 - 175	6" (16 cm)	89" (227 cm)	34" (87 cm)	34" (87 cm)	
180 - 200	6" (16 cm)	96" (244 cm)	35" (89 cm)	35" (89 cm)	
205 - 220	9" (23 cm)	96" (244 cm)	38" (97 cm)	38" (97 cm)	

30,000 – 175,000 "B,C & D" Clearances can be reduced by 50% 25' (7.5 m) downstream of burner
 180,000 – 220,000 "B,C & D" Clearances can be reduced by 50% 35' (10.7 m) downstream of burner

"U" Tube - Horizontal

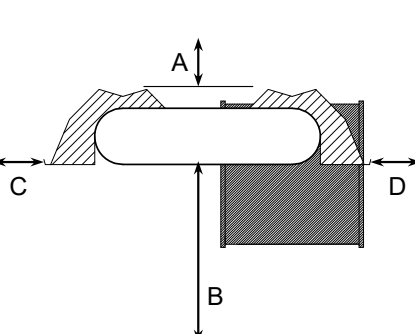
	MBH Input	A	B	C	D
	30 - 50	4" (11 cm)	40" (102 cm)	10" (26 cm)	12" (31 cm)
55 - 75	4" (11 cm)	50" (127 cm)	18" (46 cm)	22" (56 cm)	
80 - 100	4" (11 cm)	60" (153 cm)	23" (59 cm)	29" (74 cm)	
105 - 125	4" (11 cm)	76" (193 cm)	28" (72 cm)	34" (87 cm)	
130 - 150	4" (11 cm)	83" (211 cm)	32" (82 cm)	38" (97 cm)	
155 - 175	6" (16 cm)	89" (226 cm)	35" (89 cm)	40" (102 cm)	
180 - 200	6" (16 cm)	96" (244 cm)	39" (99 cm)	44" (112 cm)	
205 - 220	9" (23 cm)	96" (244 cm)	39" (99 cm)	46" (117 cm)	

CLEARANCE TO COMBUSTIBLES (CON'T)

“U” Tube – 40° Mounting

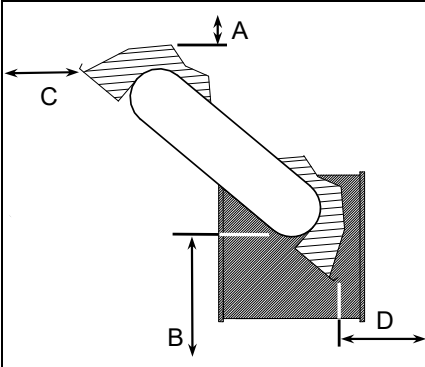
	MBH Input	A	B	C	D
	30 - 50	4" (11 cm)	40" (102 cm)	26" (66 cm)	5" (13 cm)
55 - 75	4" (11 cm)	46" (117 cm)	30" (77 cm)	7" (18 cm)	
80 - 100	4" (11 cm)	66" (168 cm)	53" (135 cm)	7" (18 cm)	
105 - 125	6" (16 cm)	76" (193 cm)	56" (143 cm)	7" (18 cm)	
130 - 150	8" (21 cm)	87" (221 cm)	68" (173 cm)	7" (18 cm)	
155 - 175	8" (21 cm)	90" (229 cm)	72" (183 cm)	7" (18 cm)	
180 - 200	8" (21 cm)	93" (237 cm)	78" (199 cm)	8" (21 cm)	
205 - 220	8" (21 cm)	96" (244 cm)	78" (199 cm)	8" (21 cm)	

“U” Tube – Opposite 40° Mounting

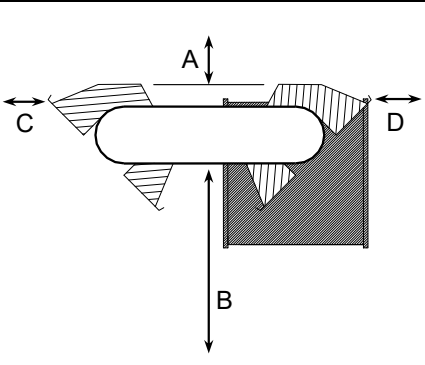
	MBH Input	A	B	C	D
	30 - 50	6" (16 cm)	40" (102 cm)	16" (41 cm)	32" (82 cm)
55 - 75	6" (16 cm)	44" (112 cm)	18" (46 cm)	35" (89 cm)	
80 - 100	6" (16 cm)	66" (168 cm)	27" (69 cm)	53" (135 cm)	
105 - 125	6" (16 cm)	76" (193 cm)	30" (76 cm)	58" (148 cm)	
130 - 150	8" (21 cm)	87" (221 cm)	35" (89 cm)	69" (176 cm)	
155 - 175	8" (21 cm)	90" (229 cm)	38" (96 cm)	75" (191 cm)	
180 - 200	8" (21 cm)	93" (237 cm)	41" (104 cm)	82" (209 cm)	
205 - 220	8" (21 cm)	96" (244 cm)	44" (112 cm)	88" (224 cm)	

Above Suspended Ceiling With Deco Grille

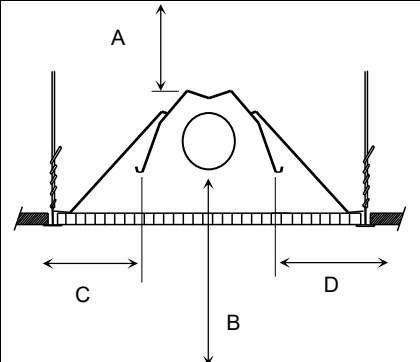
	MBH Input	A	B	C	D
	30 - 50	4" (11 cm)	40" (102 cm)	12" (31 cm)	12" (31 cm)
55 - 75	4" (11 cm)	50" (127 cm)	22" (56 cm)	22" (56 cm)	
80 - 100	4" (11 cm)	60" (153 cm)	29" (74 cm)	29" (74 cm)	
105 - 125	4" (11 cm)	76" (193 cm)	34" (87 cm)	34" (87 cm)	
130 - 150	4" (11 cm)	83" (211 cm)	38" (97 cm)	38" (97 cm)	
155 - 175	6" (16 cm)	89" (226 cm)	40" (102 cm)	40" (102 cm)	
180 - 200	8" (21 cm)	94" (239 cm)	44" (112 cm)	44" (112 cm)	
205 - 220	9" (23 cm)	96" (244 cm)	46" (117 cm)	46" (117 cm)	

30,000 – 175,000 "B,C & D" Clearances can be reduced by 50% 25' downstream of burner
 180,000 – 220,000 "B,C & D" Clearances can be reduced by 50% 35' downstream of burner

CLEARANCE TO COMBUSTIBLES (CON'T)

Unvented – Exhaust End

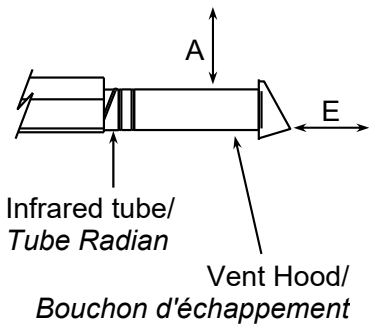
 <p>Infrared tube/ <i>Tube Radian</i></p> <p>Vent Hood/ <i>Bouchon d'échappement</i></p>	MBH Input	A	E
	30 - 50	18" (46 cm)	18" (46 cm)
	55 - 75	18" (46 cm)	18" (46 cm)
	80 - 100	20" (51 cm)	20" (51 cm)
	105 - 125	20" (51 cm)	20" (51 cm)
	130 - 150	20" (51 cm)	24" (61 cm)
	155 - 175	20" (51 cm)	24" (61 cm)
	180 - 200	20" (51 cm)	28" (72 cm)
	205 - 220	20" (51 cm)	28" (72 cm)

"U" BEND OR ELBOW END CLEARANCE

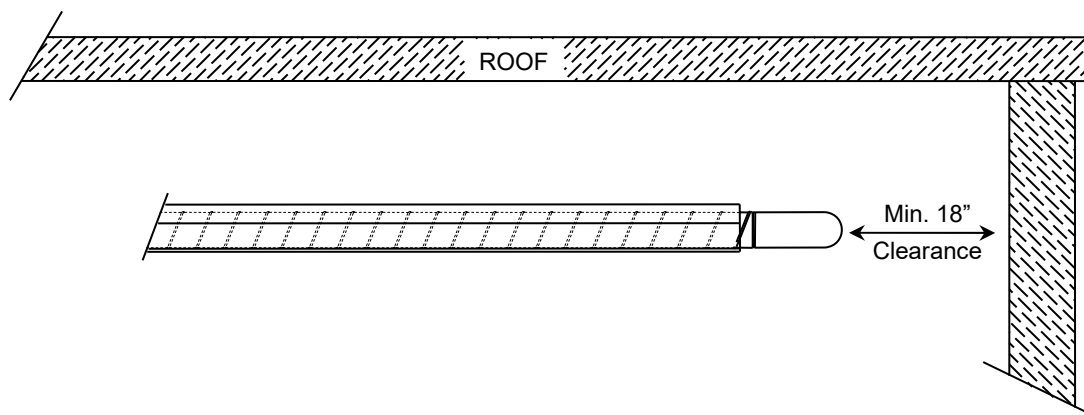

STRAIGHT & "U" TUBE ASSEMBLY

⚠ CAUTION

CUT HAZARD - SHARP EDGES.



Wear protective gloves when installing and handling and cutting radiant tubes. Failure to follow these instructions will result in personal injury.

1. Remove the Reflector(s), radiant tubes hangers and supports from the shipping carton. Inspect for shortages and damages as well as correct gas service for burners.
2. Assemble the tubes as illustrated applying one to two tablespoons (15 – 30 ml) of sealer to the inside edge of the spiral radiant tube. Use a 1" (25.4 mm) dowel or plastic tube to evenly spread the sealer around the inside edge of the spiral radiant tube before sliding the coupler/tube together. **INSTALL COMBUSTION TUBE WITH WELD SEAM ON BOTTOM AND MAKE SURE THAT THE TUBE WITH THE INTERNAL TURBULATOR IS INSTALLED AS THE LAST TUBE AS ILLUSTRATED ON THE FOLLOWING PAGES.**

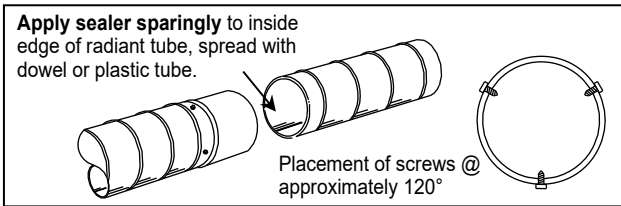
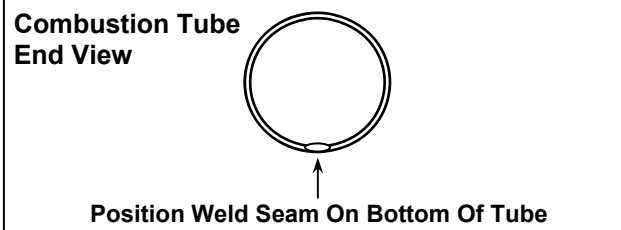

3. Next secure joints with the self drilling and tapping screws provided (use three per joint). Clean off excess sealer with a damp cloth.
4. Next install hanger supports by sliding them into place and position them as illustrated. **REFER TO PAGES 13 - 16 FOR PROPER LOCATION. NOTE:** Do not vary the location of the hangers anymore than +/- 4" from the recommendations.

IMPORTANT: Slide the reflectors into place (inside hangers) and overlap them approximately 1" to 2" and secure no more than two together with sheet metal screws. A reflector expansion joint (unsecured reflectors) at every other overlap is required for expansion and contraction of the system.

STRAIGHT TUBE SYSTEMS

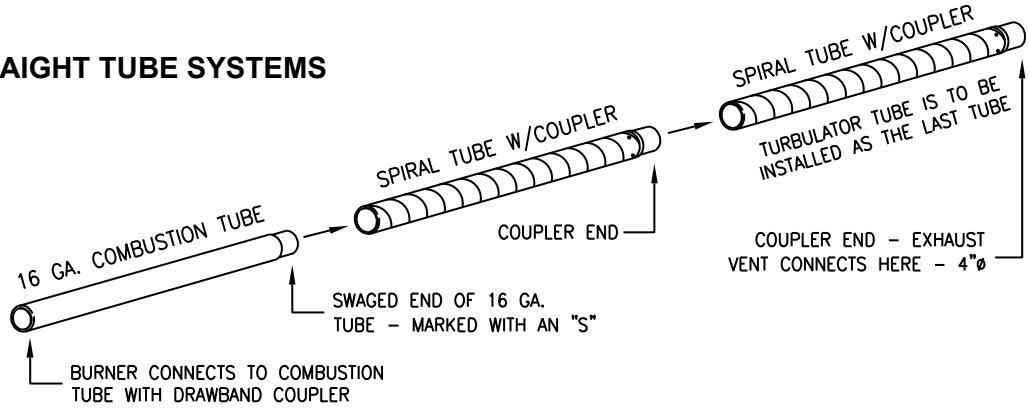

"U" TUBE SYSTEMS

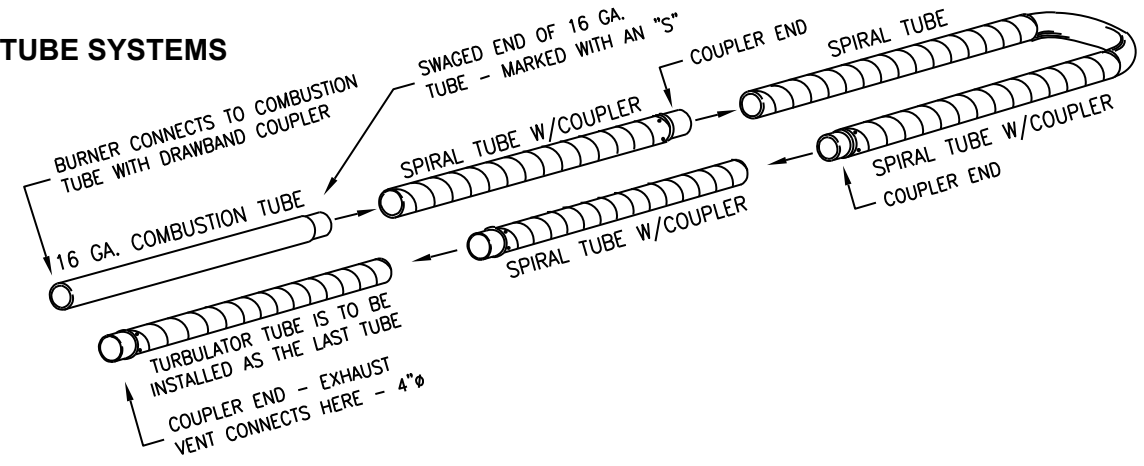

For 30 MBH Thru 175 MBH Inputs

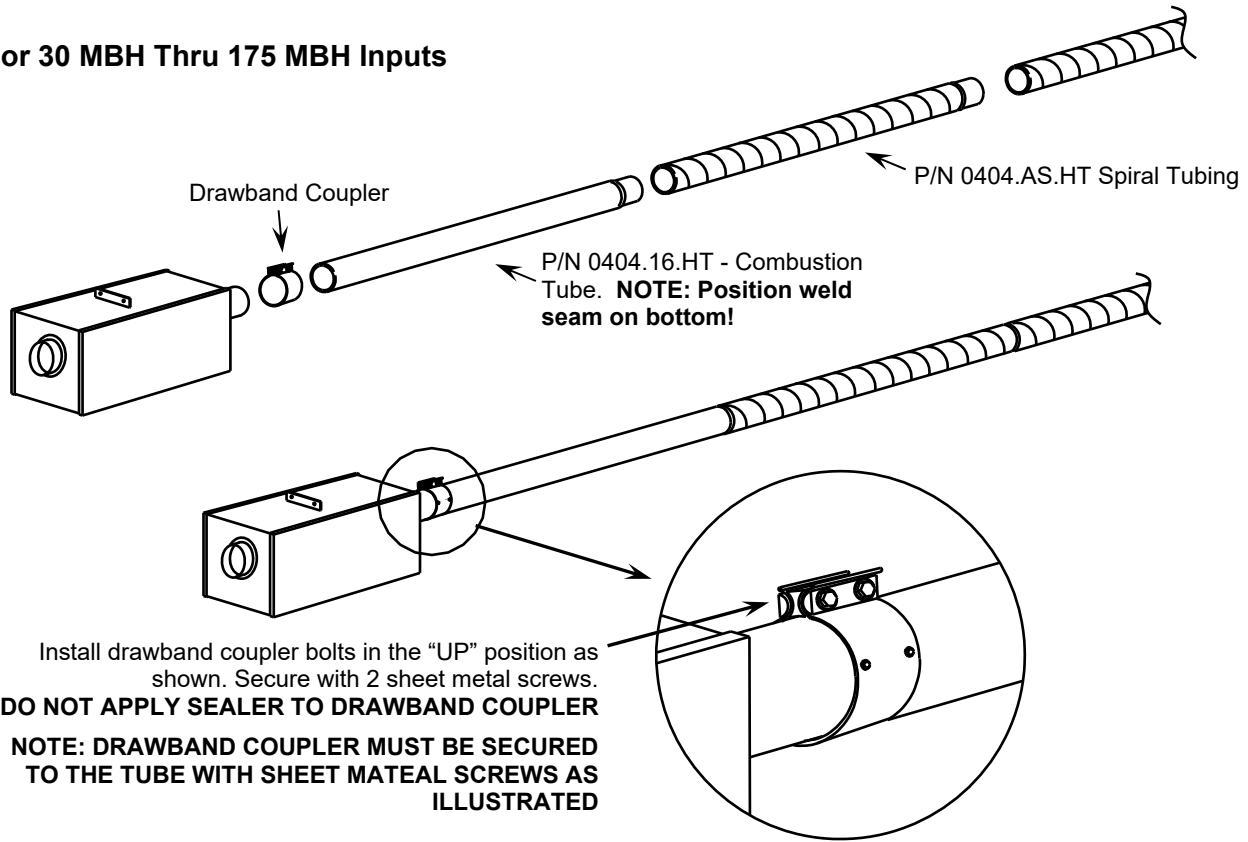

For 180 MBH Thru 220 MBH Inputs

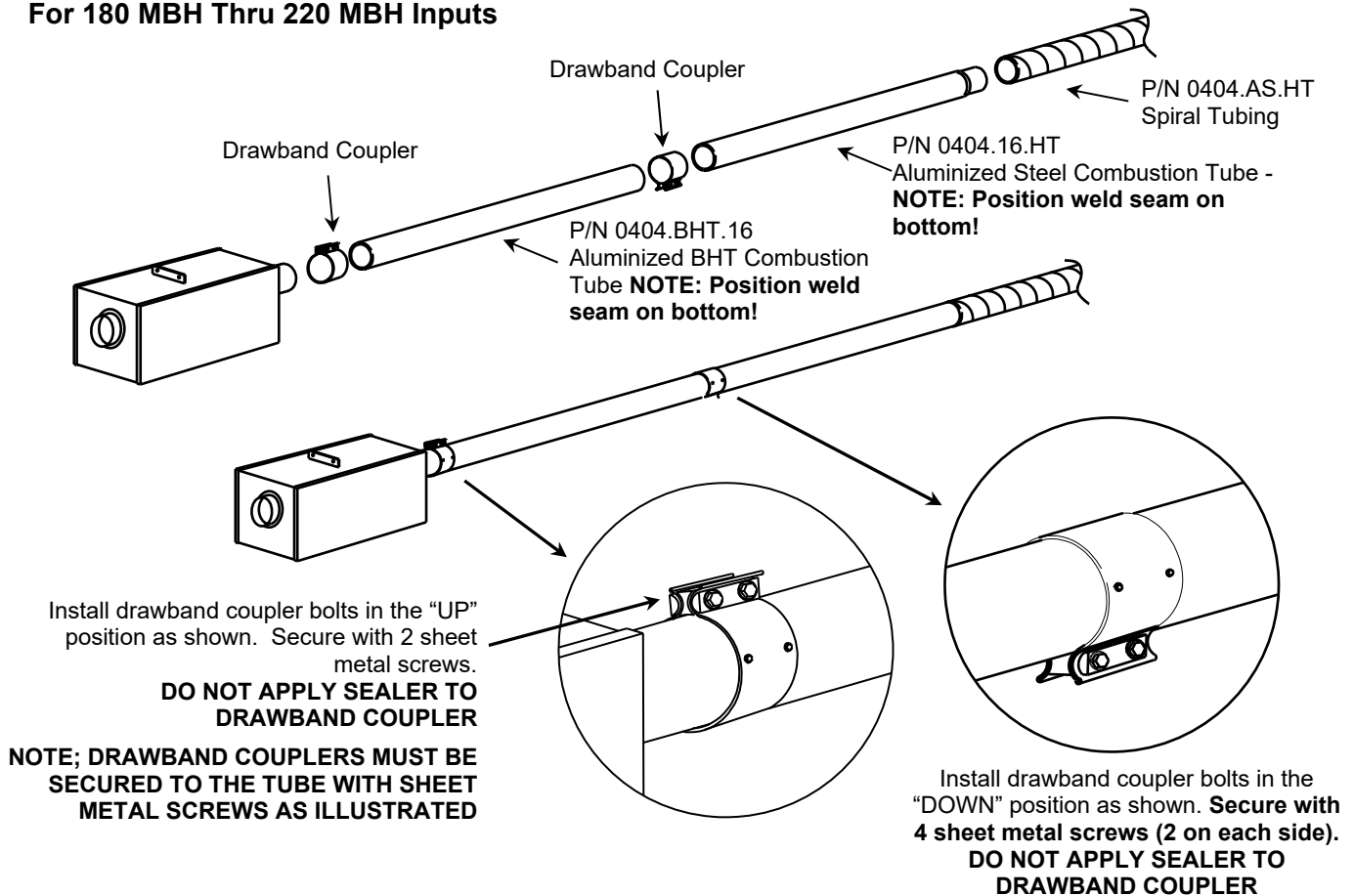

30 MBH thru 175 MBH INPUT - STRAIGHT TUBE SYSTEM

~~~~~ - TURBULATOR – SEE PAGE 15 FOR TURBULATOR LENGTH

← - BURNER END

● - HANGER

S | - REFLECTOR SUPPORT

E ↓ - REFLECTOR OVERLAPPING EXPANSION JOINT

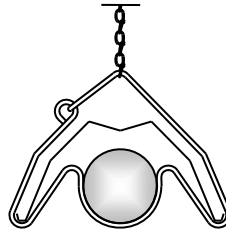

**10' SYSTEM**



**20' SYSTEM**

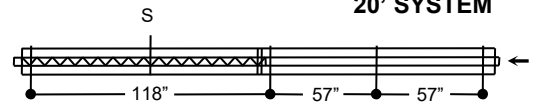

**30' SYSTEM**

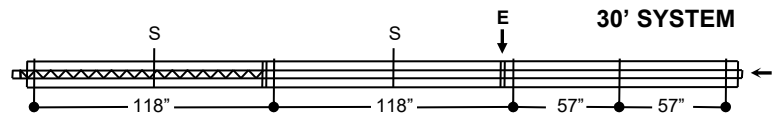

**40' SYSTEM**

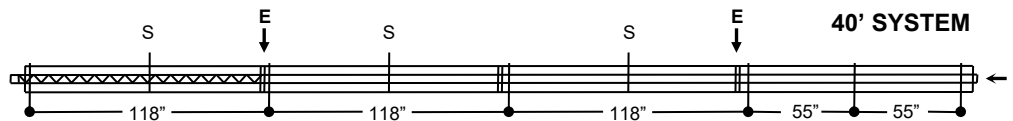

**50' SYSTEM**

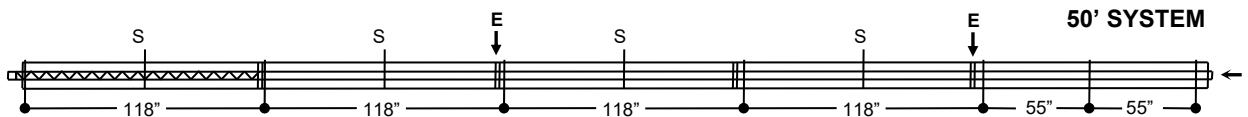

**60' SYSTEM**

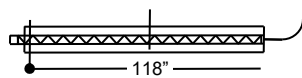
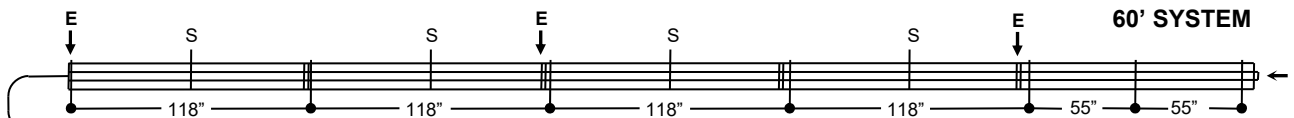



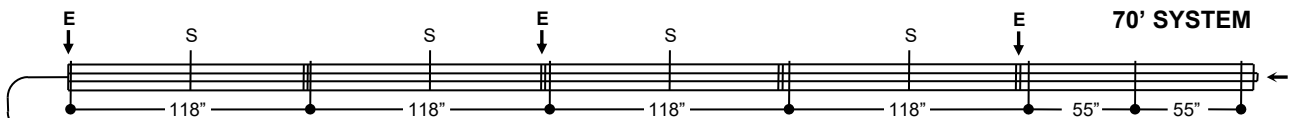

**70' SYSTEM**



**IMPORTANT:** A reflector expansion joint (unsecured reflectors) at every other overlap is required for expansion and contraction of the system. Failure to do so will result in reflectors buckling and system noise!

**BTU INPUTS OF 180 MBH AND GREATER - STRAIGHT TUBE SYSTEM**

-  - TURBULATOR - SEE PAGE 15 FOR TURBULATOR LENGTH
-  - BURNER END
-  - HANGER
-  - REFLECTOR SUPPORT
-  - REFLECTOR OVERLAPPING EXPANSION JOINT

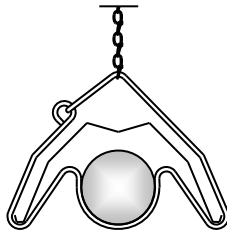

**IMPORTANT:** A reflector expansion joint (unsecured reflectors) at every other overlap is required for expansion and contraction of the system. Failure to do so can result in reflectors buckling and system noise!

**30 MBH thru 175 MBH INPUT SYSTEMS – “U” TUBE SYSTEM**

~~~~~ - TURBULATOR – SEE PAGE 15  
FOR TURBULATOR LENGTH

← - BURNER END

• - HANGER

S - REFLECTOR SUPPORT

E - REFLECTOR OVERLAPING
EXPANSION JOINT

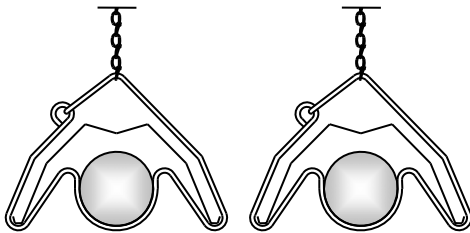

10' "U" SYSTEM
20' Tube Length

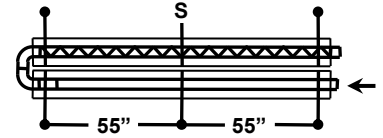

15' "U" SYSTEM
30' Tube Length

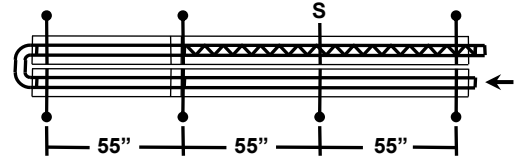

20' "U" SYSTEM
40' Tube Length

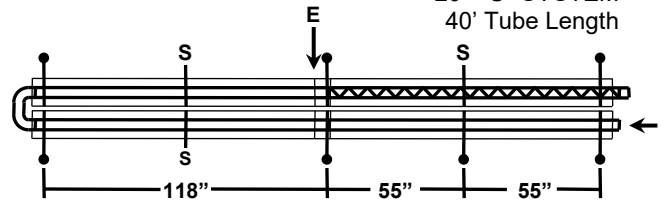

25' "U" SYSTEM
50' Tube Length

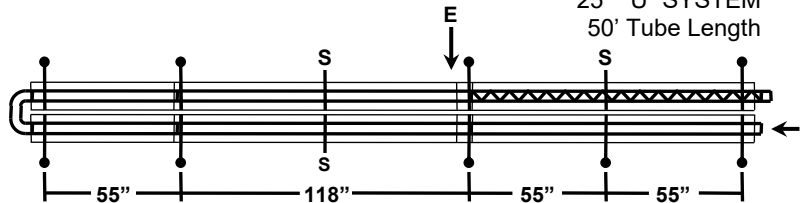



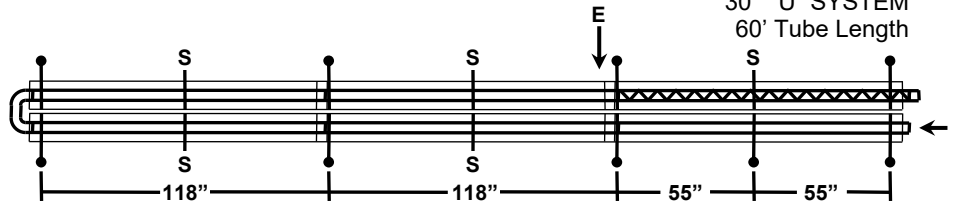

30' "U" SYSTEM
60' Tube Length

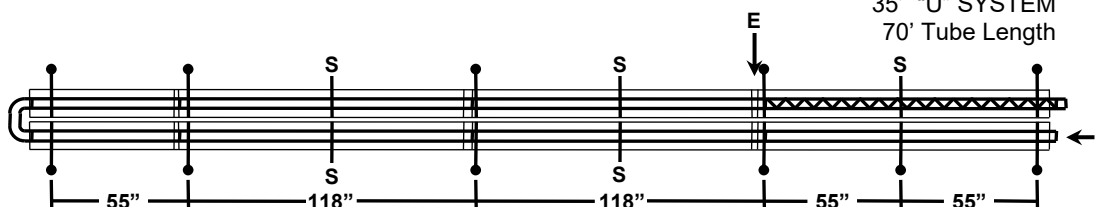

35' "U" SYSTEM
70' Tube Length



180 MBH thru 220 MBH INPUT SYSTEMS – “U” TUBE SYSTEM

-  - TURBULATOR – SEE PAGE 15 FOR TURBULATOR LENGTH
-  - BURNER END
-  - HANGER
-  - REFLECTOR SUPPORT
-  - REFLECTOR OVERLAPPING EXPANSION JOINT

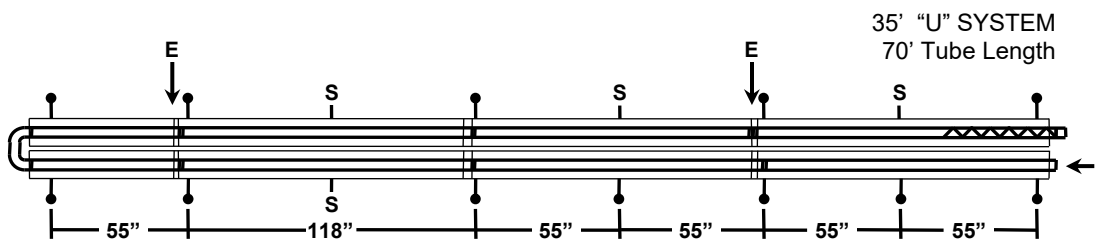
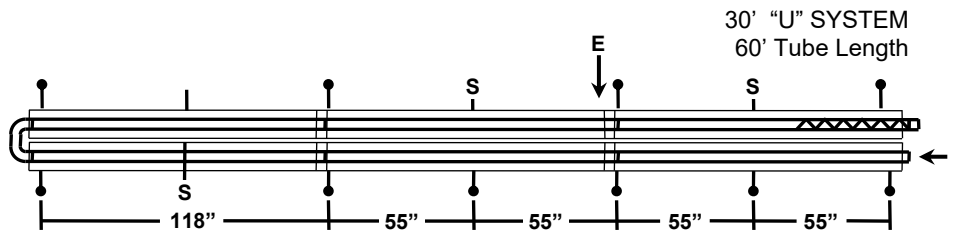
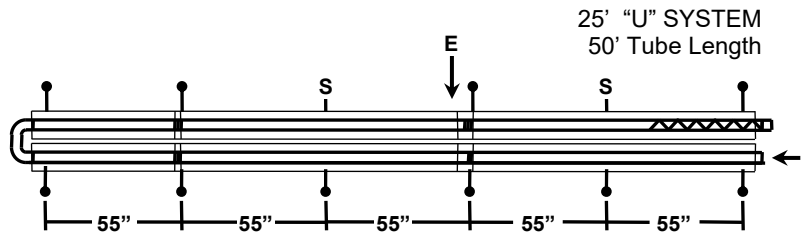
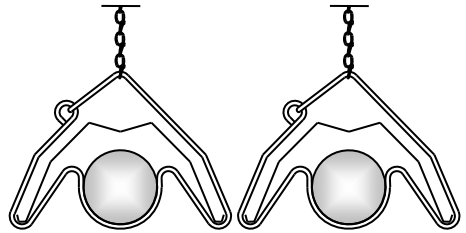

SYTEM DIMENSIONS

| BURNER PART NUMBER | MBH INPUT | A
(STRAIGHT TUBE SYSTEM) | B
("U" TUBE SYSTEM) | TURBULATOR BAFFEL LENGTH |
|--------------------|-----------|-----------------------------|---------------------------|---|
| 0D9030.NG/LP | 30 / 20 | 10'-0" / 14'-9" / 19'-8" | 11' | 104" |
| 0D9040.NG/LP | 40 / 27 | 10'-0" / 14'-9" / 19'-8" | 11' | (10' STRAIGHT SYS. – 84") |
| 0D9050.NG/LP | 50 / 35 | 15'-5" / 19'-8" / 29'-8" | 11' / 14'-8" | 104" |
| 0D9055.NG/LP | 55 / 38 | 15'-5" / 19'-8" / 29'-8" | 11' / 14'-8" | 104" |
| 0D9060.NG/LP | 60 / 39 | 15'-5" / 19'-8" / 29'-8" | 11' / 14'-8" | 104" |
| 0D9065.NG/LP | 65 / 42 | 19'-8" / 29'-10" / 39'-6" | 11' / 14'-8" / 20'-2" | (72" TURBULATOR FOR 39'-6" STRAIGHT TUBE & 20'-2" U TUBE SYSTEMS) |
| 0D9070.NG/LP | 70 / 46 | 19'-8" / 29'-10" / 39'-6" | 11' / 14'-8" / 20'-2" | 104" |
| 0D9075.NG/LP | 75 / 49 | 19'-8" / 29'-10" / 39'-6" | 11' / 14'-8" / 20'-2" | 104" |
| 0D9080.NG/LP | 80 / 53 | 19'-8" / 29'-10" / 39'-6" | 11' / 14'-8" / 20'-2" | 104" |
| 0D9085.NG/LP | 85 / 55 | 19'-8" / 29'-8" / 39'-6" | 11' / 14'-8" / 20'-2" | 104" |
| 0D9090.NG/LP | 90 / 58 | 19'-8" / 29'-8" / 39'-6" | 11' / 14'-8" / 20'-2" | 104" |
| 0D9095.NG/LP | 95 / 62 | 29'-8" / 39'-6" | 14'-8" / 20'-2" | 104" |
| 0D9100.NG/LP | 100 / 64 | 29'-8" / 39'-6" | 14'-8" / 20'-2" | 104" |
| 0D9105.NG/LP | 105 / 66 | 29'-8" / 39'-6" / 49'-4" | 14'-8" / 20'-2" / 25'-1" | 104" |
| 0D9110.NG/LP | 110 / 70 | 29'-8" / 39'-6" / 49'-4" | 14'-8" / 20'-2" / 25'-1" | 104" |
| 0D9115.NG/LP | 115 / 73 | 29'-8" / 39'-6" / 49'-4" | 14'-8" / 20'-2" / 25'-1" | 104" |
| 0D9120.NG/LP | 120 / 77 | 29'-8" / 39'-6" / 49'-4" | 20'-2" / 25'-1" | 104" |
| 0D9125.NG/LP | 125 / 80 | 29'-8" / 39'-6" / 49'-4" | 20'-2" / 25'-1" | 104" |
| 0D9130.NG/LP | 130 / 85 | 39'-6" / 49'-4" | 20'-2" / 25'-1" | 104" |
| 0D9135.NG/LP | 135 / 57 | 39'-6" / 49'-4" | 20'-2" / 25'-1" | 104" |
| 0D9140.NG/LP | 140 / 90 | 39'-6" / 49'-4" | 20'-2" / 25'-1" | 104" |
| 0D9145.NG/LP | 145 / 93 | 39'-6" / 49'-4" | 20'-2" / 25'-1" | 104" |
| 0D9150.NG/LP | 150 / 95 | 39'-6" / 49'-4" / 59'-2" | 20'-2" / 25'-1" / 29'-10" | 72" |
| 0D9155.NG/LP | 155 / 100 | 39'-6" / 49'-4" / 59'-2" | 20'-2" / 25'-1" / 29'-10" | 72" |
| 0D9160.NG/LP | 160 / 103 | 39'-6" / 49'-4" / 59'-2" | 20'-2" / 25'-1" / 29'-10" | 72" |
| 0D9165.NG/LP | 165 / 107 | 39'-6" / 49'-4" / 59'-2" | 20'-2" / 25'-1" / 29'-10" | 72" |
| 0D9170.NG/LP | 170 / 110 | 39'-6" / 49'-4" / 59'-2" | 20'-2" / 25'-1" / 29'-10" | 72" |
| 0D9175.NG/LP | 175 / 112 | 39'-6" / 49'-4" / 59'-2" | 20'-2" / 25'-1" / 29'-10" | 34" TURBULATOR
NO TURBULATOR ON
69'-1" STRAIGHT OR
34'-9" U SYSTEMS |
| 0D9180.NG/LP | 180 / 115 | 49'-4" / 59'-2" / 69'-1" | 25'-1" / 29'-10" / 34'-9" | |
| 0D9185.NG/LP | 185 / 117 | 49'-4" / 59'-2" / 69'-1" | 25'-1" / 29'-10" / 34'-9" | |
| 0D9190.NG/LP | 190 / 120 | 49'-4" / 59'-2" / 69'-1" | 25'-1" / 29'-10" / 34'-9" | |
| 0D9195.NG/LP | 195 / 125 | 49'-4" / 59'-2" / 69'-1" | 25'-1" / 29'-10" / 34'-9" | |
| 0D9200.NG/LP | 200 / 127 | 49'-4" / 59'-2" / 69'-1" | 25'-1" / 29'-10" / 34'-9" | NO TURB EXCEPT FOR
34" TURBULATOR ON
49'-4" STRAIGHT TUBE &
25'-1" "U" TUBE SYSTEM |
| 0D9205.NG/LP | 205 / 128 | 49'-4" / 59'-2" / 69'-1" | 25'-1" / 29'-10" / 34'-9" | |
| 0D9210.NG/LP | 210 / 134 | 49'-4" / 59'-2" / 69'-1" | 25'-1" / 29'-10" / 34'-9" | |
| 0D9215.NG/LP | 215 / 139 | 49'-4" / 59'-2" / 69'-1" | 25'-1" / 29'-10" / 34'-9" | |
| 0D9220.NG/LP | 220 / 145 | 49'-4" / 59'-2" / 69'-1" | 25'-1" / 29'-10" / 34'-9" | |

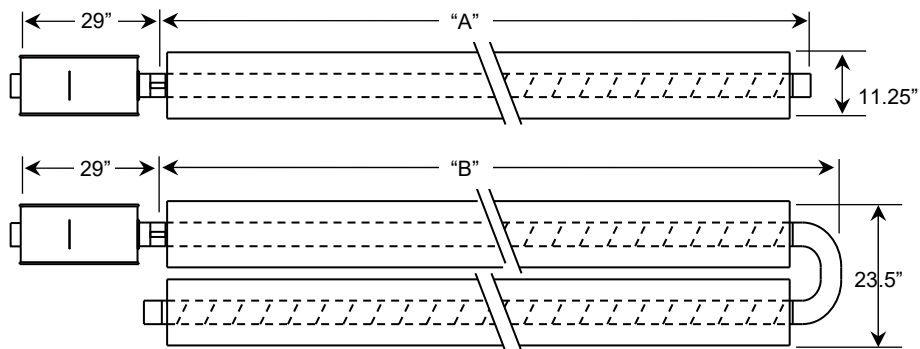

SYSTEM MOUNTING GUIDELINES

The following chart is intended to be a general guideline. The amount or number of heating systems should be determined by the heat load calculation. Buildings with low heat loss or installations where distances between systems exceed these recommendations shown below may require additional heating systems to uniformly cover the

space to be heated. Applications that include outdoor patios, spot heating and high bay installations (such as aircraft hangars) often require heaters to be installed outside these recommendations. Consideration of heater placement should be given to racks or shelves as well as overhead door locations and their frequency of use. In all instances the clearance to combustibles must be maintained.

Omega II® System Installation Chart

| MBH Input | System Tube Length | Suggested Mounting Height | "X" - Distance Between Systems | Straight Tube Coverage (L x W) | U-Tube Coverage (L x W) | "Y" - Distance Between System Rows | "Z" - Typical Distance From Wall |
|-----------|--------------------|---------------------------|--------------------------------|--------------------------------|-------------------------|------------------------------------|----------------------------------|
| 30 – 40 | 10' | 8.5' – 14' | 10' – 25' | 10' x 10' | DNA | 20' – 40' | 15' |
| 30 – 40 | 20' | | | 20' x 10' | 10' x 12' | | |
| 50 – 60 | 20' | 10' – 16' | 10' – 25' | 21' x 13' | 10' x 14' | 20' – 50' | 16' |
| 50 – 60 | 30' | | | 31' x 13' | 16' x 14' | | |
| 65 – 75 | 20' | 12' – 18' | 20' – 30' | 22' x 15' | 12' x 16' | 20' – 50' | 18' |
| 65 – 75 | 40' | | | 42' x 15' | 22' x 16' | | |
| 80 - 100 | 30' | 13' – 20' | 20' – 30' | 32' x 16' | 16' x 17' | 20' – 50' | 20' |
| 80 - 100 | 40' | | | 42' x 16' | 23' x 17' | | |
| 105 – 115 | 30' | 14' – 20' | 20' – 30' | 33' x 18' | 17' x 19' | 30' – 50' | 20' |
| 105 – 115 | 50' | | | 53' x 18' | 28' x 19' | | |
| 120 – 150 | 40' | 15' – 25' | 20' - 30' | 44' x 22' | 23' x 22' | 30' – 50' | 25' |
| 120 – 150 | 60' | | | 44' x 22' | 33' x 22' | | |
| 155 – 175 | 40' | 16' – 30' | 30' – 40' | 45' x 25' | 24' x 25' | 40' – 50' | 25' |
| 155 - 175 | 70' | | | 75' x 25' | 38' x 25' | | |
| 180 – 220 | 50' | 18' – 40' | 30' – 40' | 54' x 28' | 28' x 28' | 40' – 60' | 30' |
| 180 - 220 | 70' | | | 75' x 28' | 38' x 28' | | |

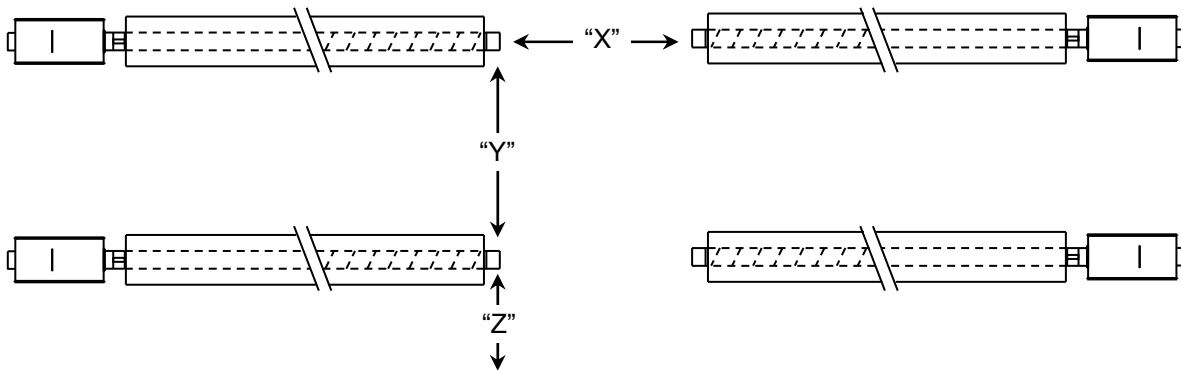

SUSPENSION

⚠ WARNING

COLLAPSE, FIRE AND EXPLOSION HAZARD



Improper suspension of the tube heater may result in collapse and being crushed. Always suspend from a permanent and secure part of the building structure that can evenly support the total force and weight of entire the heating system.

Failure to maintain minimum clearance to combustibles may result in fire and/or explosion, property damage, serious injury or death. Always maintain minimum clearances and post clearance signs where needed.

Combustion Research Corporation recommends that *Omega II*® systems are hung by means of chain. Chain and "S" hooks are supplied as an option. **DO NOT STRETCH OR INSTALL CHAIN OTHER THAN IN A VERTICAL FASHION WHEN INITIALLY INSTALLED (BURNER NOT FIRING).**

If chain is not supplied by Combustion Research Corp., furnish a chain with a minimum 90 lb. workload (trade size #3 or larger). See chart below for recommended minimum hanging chain lengths. This allows for system expansion and contraction, reducing the likelihood of reflector and radiant tube warping and/or expansion noise.

CAUTION: Infrared tube systems expand and contract upon each call for heat.

| System Length | Typical Expansion | Min. Chain Length |
|-----------------------|---------------------|-------------------|
| Up to 40' (12 m) | 1" - 2" (3 - 6 cm) | 12" (30 cm) |
| 50' - 60' (15 - 18 m) | 2" - 3" (6 - 8 cm) | 18" (46 cm) |
| 70' - 80' (21 - 24 m) | 3" - 4" (8 - 10 cm) | 24" (61 cm) |

Provisions must be made to limit lateral movement when systems are installed in site conditions where open doors may create a windy condition – see page 22 & 23 for guidelines.

Radiant tubes do not require sloping.

For fine adjustment turnbuckles may be used.

NOTES:

- SECURE TURNBUCKLES (WHEN USED) SO THAT THEY WILL NOT UNWIND OR UN-SCREW.
- CRIMP "S" HOOKS CLOSED BEFORE LEAVING JOB.

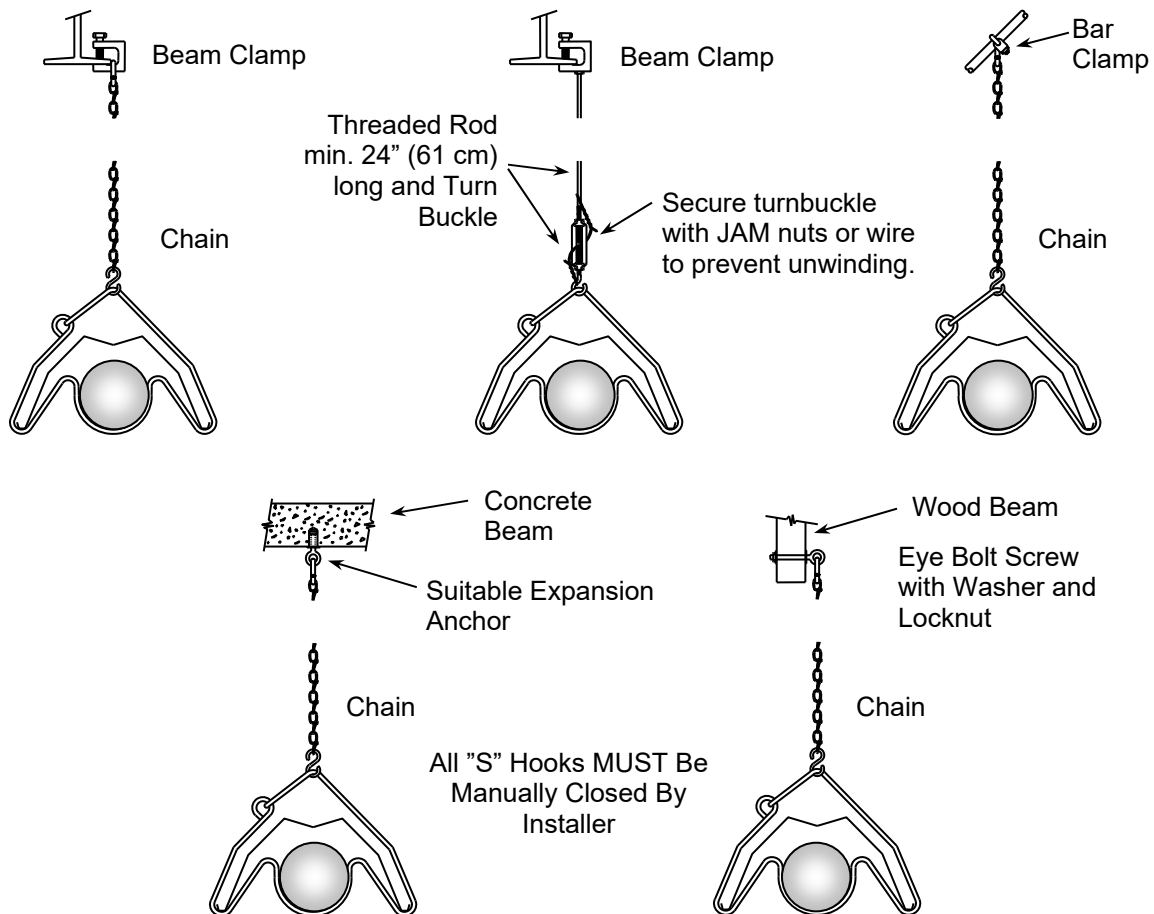

COMBUSTION TUBE INSTALLATION

The first section or radiant tube downstream of the burner is a heavy wall 16 Ga. heat-treated aluminized steel tube, this applies to BTU inputs of 30 MBH thru 175 MBH. For BTU inputs of 180 MBH and higher the first two sections of radiant tube downstream of the burner shall consist of a 16 Ga. heat treated aluminized BHT alumatherm tube (0404.BHT.16) and then the second tube a heat treated 16 Ga. aluminized steel tube (0404.16.HT). Refer to page 10 for proper installation of these heavy wall tubes. **It is**

necessary that the weld seam on the combustion tube(s) be positioned so that it is on the bottom when installed – see illustration below. This applies for both straight tube and “U” tube systems. When the systems are mounted on a 40° angle the weld seam should always be on the bottom.

The drawband coupler that joins the 16 Ga. BHT Alumatherm tube and the 16 GA Aluminized steel tube together must be secured to the 16 Ga. Tube with 4 sheet metal screws. See pg. 10 for assembly details.

Install Combustion Tube with Weld Seam On Bottom

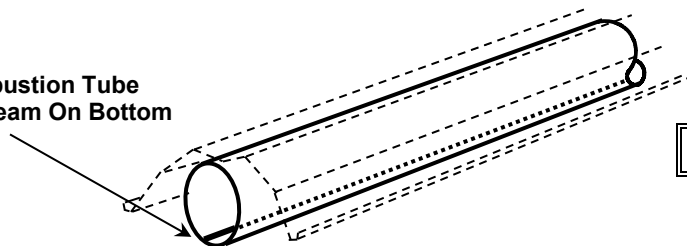

! IMPORTANT !

TUBE & REFLECTOR HANGING METHODS

The Omega II® system reflectors can be suspended horizontally or at a 40° angle. The combination hanger is designed so that the reflector angle will be horizontal when

suspended from the top loop or at a 40° angle when suspended from the offset loop – see the illustration below.

The “U” Tube arrangement may also be suspended horizontally or at a 40° angle – see illustration below.

Horizontal Mounting With “Combination” Hanger

40° Mounting With “Combination” Hanger

Horizontal Mounting “U” Tube Configuration

40° Mounting “U” Tube Configuration#

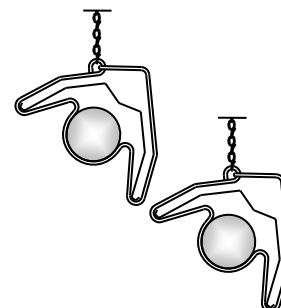
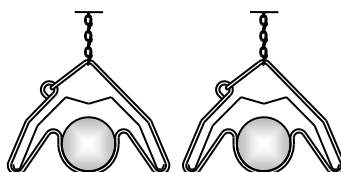
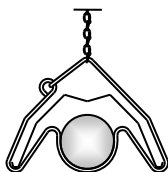

CUSTOMIZING SYSTEMS

Straight tube systems can be customized with a maximum of two 90° or four 45° elbows. These elbows can only be installed in the spiral radiant tube. The tube couplers that have been factory installed will have to be removed to accommodate the installation of any elbows. The radiant tube system can be shortened provided the minimum tube

length is maintained. The last tube which contains the turbulator shall not be shortened. Any additional elbows, radiant tube and reflector is optional equipment.

DO NOT INSTALL OR JAM TURBULATORS IN ELBOWS OR “U” BENDS. CONSULT YOUR REPRESENTATIVE OR THE FACTORY FOR PROPER INSTALLATION & GUIDANCE.

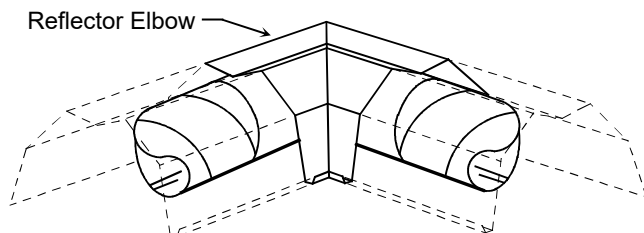

Secure To Connecting Reflector With Sheet Metal Screws

SIDE SHIELD INSTALLATION

The side shield may be installed on either side of the reflector or on both sides of the reflector. Refer to the layout plan and clearance to combustible chart for proper location and clearance information.

Install one ten-foot side shield in conjunction with each ten-foot section of reflector so that overlap joints align. The side shield is to be hung vertically, do not modify this vertical suspension.

Cut a suitable relief notch for every reflector hanger and support.

The side shield is to be hung vertically and fastened to the reflector with #8 self-drilling and tapping screws, one near each end and approximately one every two feet. The side shield expansion joint must match the reflector expansion joint. **DO NOT SCREW THE OVERLAPPING EXPANSION JOINTS TOGETHER.**

0363.00 REFLECTOR & 0366.00 SIDE SHIELD

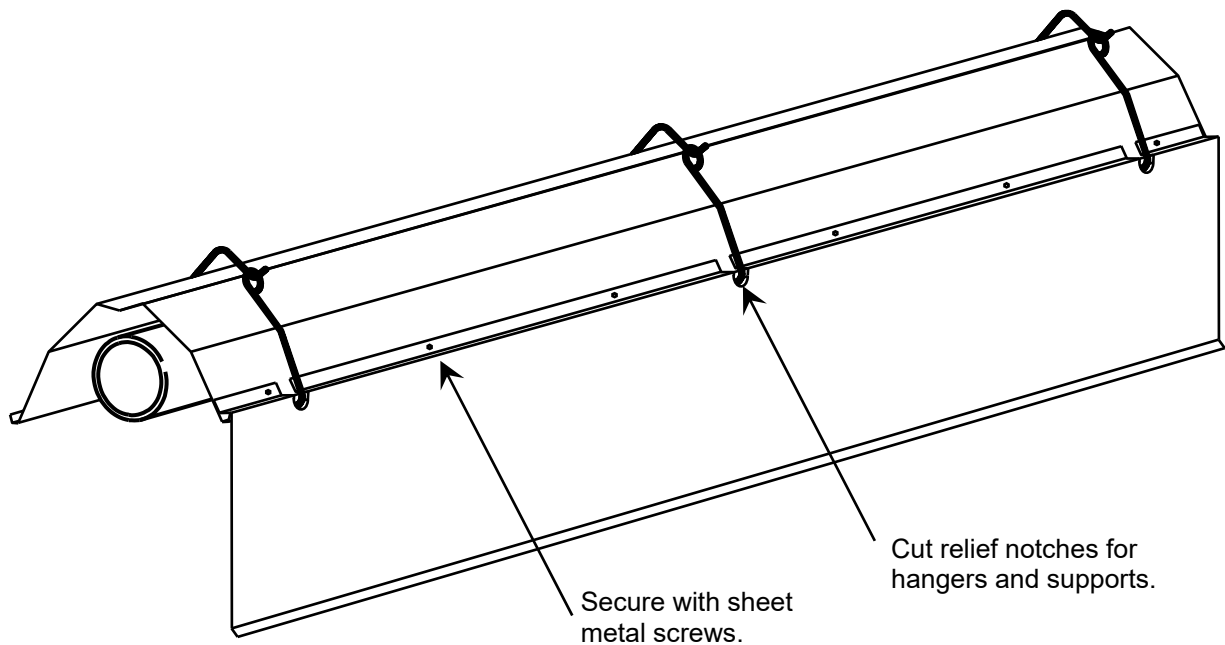
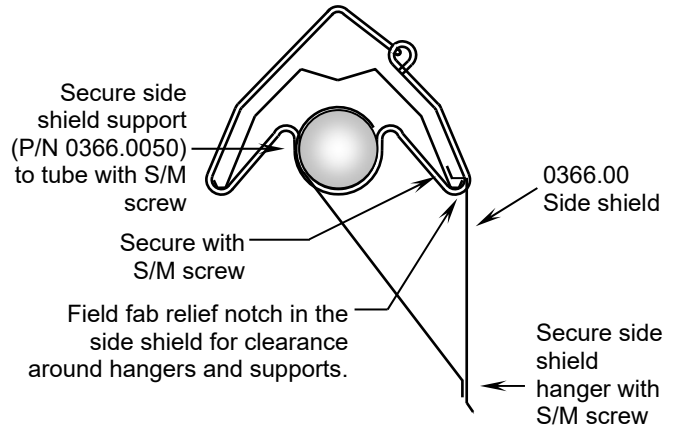

DECORATIVE GRILLE WITH SUSPENDED CEILING INSTALLATION

⚠ CAUTION

CUT HAZARD - SHARP EDGES.



Wear protective gloves when installing and handling aluminum decorative grille and side shields. Failure to follow these instructions will result in personal injury.

When installing the heating system above a suspended ceiling, decorative grille must be used directly beneath the radiant tube system. The use of regular ceiling tiles directly beneath the radiant tube will create an unsafe condition.

The decorative grille provides an attractive finish to the system when installed over a suspended ceiling. The aluminum Decorative Grille (PN 0369.00) comes in standard 2 ft. x 4 ft. (60 cm x 120 cm) sections and is installed in place of the ceiling tile. The decorative grill should extend completely under all of the radiant tube as well as the burner assembly.

The radiant tube is suspended in normal fashion, centered over the decorative grille. The radiant tube must be installed, as shown below, with a minimum distance from the radiant tube to the decorative grille of 7" (17.8 cm) to a maximum of 10" (25.4 cm).

"T" bar heat shields (PN 0369.21) must be installed over ceiling "T" frame members that pass underneath the radiant tube. The Decorative Grille Side Shield reflector (PN 0369.11) is available in 10-ft. (3 m) lengths. Lay the side shield along the standard reflector and cut suitable notches for the reflector hangers and "T" bar sections. Work gloves should be worn as sharp edges can be encountered when working with the aluminum decorative grille and side shields.

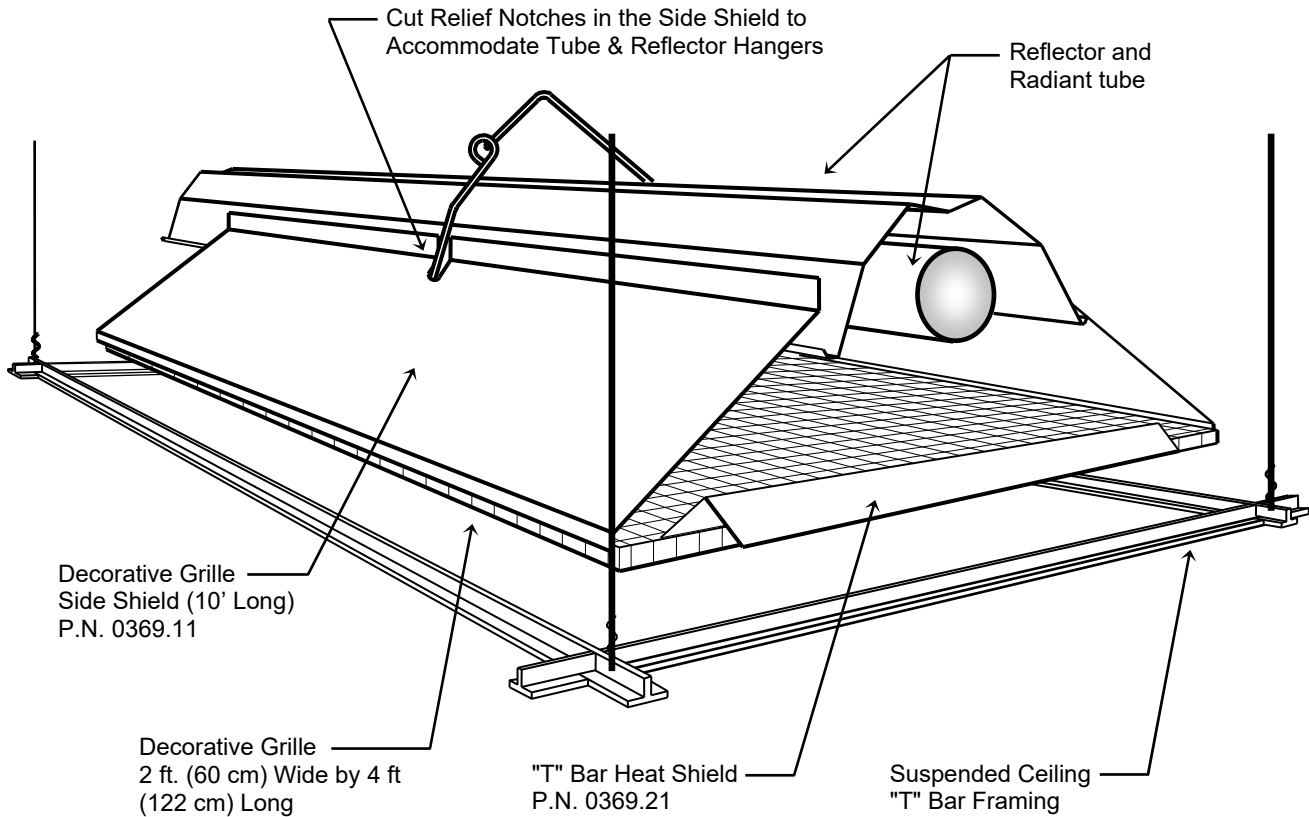

SEISMIC RESTRAINT SUSPENSION METHODS

For standard seismic restraint such as earthquake prone areas, install seismic restraint chain or cable as shown below. If high winds can be encountered in the building, such as found in airplane hangars where opposing doors are simultaneously open, or system is installed near or below the door opening, additional support of the radiant tube and reflector network will be required. See the "Seismic Suspension For High Wind Applications" for

details. If there are any questions regarding what method is best suited for your application consult your sales representative or contact the factory.

Locate lateral restraint at each end of the system and at 20 ft. intervals. Locate a minimum of one longitudinal restraint midpoint of the system with a maximum spacing of 40 ft. The loose longitudinal chain (wire rope) will allow for system expansion without binding or lifting of the radiant tube



Typical Turnbuckle (if used)
To prevent possible unwinding wire eyelets as shown.

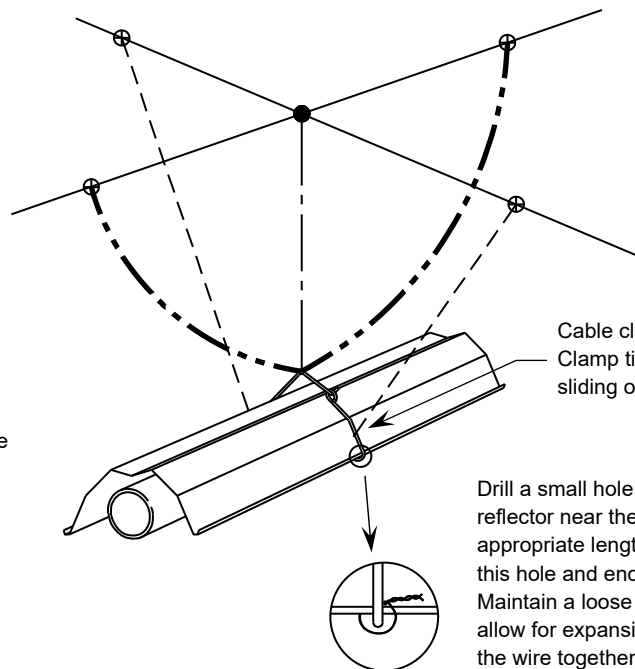

Cable clamp P/N 1800.HC.000
Clamp tight to prevent chain or cable from sliding on hanger.

Drill a small hole (approximately 1/8"Ø) in the reflector near the combination hanger. Insert an appropriate length of 14 Ga. galvanized wire through this hole and encircle the combination hanger. Maintain a loose loop around the hanger, this will allow for expansion of the system. Twist the ends of the wire together and trim as required. This retention wire may be installed on both sides or edges of the reflector for severe wind conditions.

- BUILDING STRUCTURE
- · — · — SUSPENSION CHAIN OR 3/8" THREADED ROD
- - - - - LATERAL RESTRAINT - TAUT CHAIN OR CABLE, MAX. 20' INTERVALS
- · — · — **LONGITUDINAL RESTRAINT** - LOOSE CHAIN OR CABLE - PARALLEL WITH SYSTEM EXPANSION. STARTING AT THE BURNER, INSTALL EVERY 5TH SUSPENSION POINT.
- MAIN VERTICAL SUSPENSION POINT
- ⊕ LATERAL & LONGITUDINAL SUSPENSION POINTS @ 30° TO 45° OFFSET FROM MAIN VERTICAL SUSPENSION POINT

SEISMIC RESTRAINT FOR HIGH WIND APPLICATION

In high wind conditions it is recommended that seismic restraints and reflector retention wire be installed. See details below for recommended installation of seismic restraint and anti-sway retention chains (wire rope). The vertical threaded rod shall be attached and suspend the reflector hangers at intervals of eight to ten feet (8' - 10'). At least one vertical threaded rod shall be placed at every elbow and/or tee connection. The threaded rod is used to prevent the system from lifting during windy conditions, the

chain or wire rope will keep the system from swaying from side to side. When connecting threaded rod to "Z" purlin use beam clamp or drill a hole through "Z" purlin and secure with two 3/8" nuts and a lock washer. If the system is a straight system (no elbows) or a "U" bend configuration, apply loose longitudinal chain or wire rope which is parallel to the radiant tube system at approximately the middle of the run. The loose chain will allow for system expansion without binding or lifting of the radiant tube.

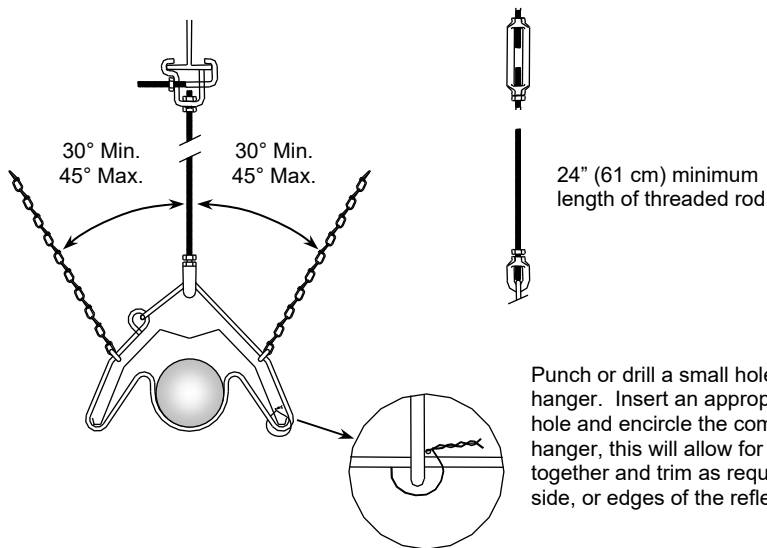

CONNECTING BURNER ASSEMBLY TO RADIANT TUBE/REFLECTOR ASSEMBLY

! WARNING

FIRE OR EXPLOSION HAZARD



IMPROPER INSTALLATION, ADJUSTMENT, ALTERATION, SERVICE OR MAINTENANCE CAN CAUSE DEATH, SEVERE INJURY AND/OR PROPERTY DAMAGE.

There is expansion of the radiant pipe with each firing cycle and this will cause the burner to move with respect to the gas line. This can cause an unsafe condition if the gas pipe connection is not done in strict accordance to the instructions.

1. Remove the burner assembly from its shipping carton and using chain or threaded rod, hang the burner so that it butts up to the 16 Ga. tube of the tubing and reflector assembly, and connect the two with the drawband coupler provided. **IMPORTANT NOTE - THE WELD SEAM OF THE 16GA. TUBE(S) MUST BE POSITIONED SO THAT IT IS ON THE BOTTOM.** Position drawband bolting assembly on the **TOP SIDE** of the tube assembly as shown - **DO NOT APPLY SEALER TO THE DRAWBAND COUPLER.** After tightening the coupler, check to make sure the burner is lined up squarely - reposition as may be required and re-tighten the drawband coupler. **Secure with 2 sheet metal screws.** See illustration below. Install reflector end cap at the burner end of the reflector. Fasten to reflector with sheet metal screws.

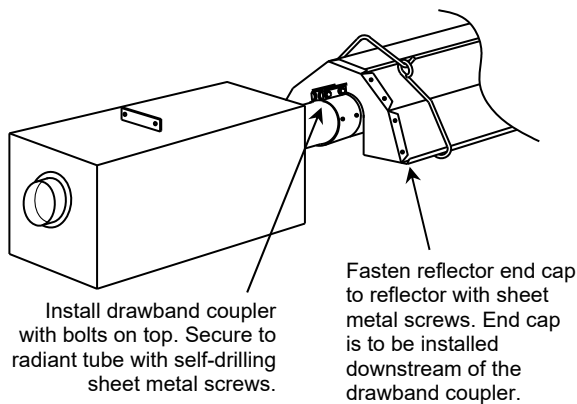

2. Connect the thermostat, gas and electrical supplies and hook up the exhaust flue and combustion air supply as outlined in this manual.
3. The system is now ready to be fired. Refer to the START UP section of this manual.

NOTES: Heater must be independently supported and not rely on the gas line or electrical line for any of its support.

If there is not a convenient point for suspending the hanging chain above the heater DO NOT try to "stretch" the span by having severe angles on the chain. Rather build a bridge between the existing building structure using angle iron, Uni-strut, etc. and then suspend the chain so that it hangs vertically.

! WARNING

FIRE OR EXPLOSION HAZARD



IMPROPER INSTALLATION, ADJUSTMENT, ALTERATION, SERVICE OR MAINTENANCE CAN CAUSE DEATH, SEVERE INJURY AND/OR PROPERTY DAMAGE.

To ensure proper burner performance the burner head assembly **MUST** be mounted vertically even when tube and reflector assembly is angle mounted. Failure to do so may result in erratic pressure switch operation.

BURNER DIMENSIONS

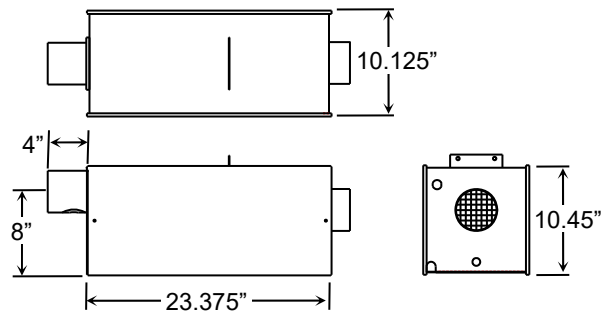

NOTE: On "U" tube systems, install exhaust end of radiant tube preferably on the right-hand side of burner assembly looking at the inlet of the burner. This will allow easy access to burner controls.

GAS SUPPLY

! WARNING

FIRE OR EXPLOSION HAZARD



IMPROPER INSTALLATION, ADJUSTMENT, ALTERATION, SERVICE OR MAINTENANCE CAN CAUSE DEATH, SEVERE INJURY AND/OR PROPERTY DAMAGE.

Follow these warnings exactly.

1. Disconnect power supply before wiring to prevent electrical shock or equipment damage.
2. To avoid dangerous accumulation of fuel gas, turn off gas supply at the appliance service valve before starting installation, and perform Gas Leak Test after completion of installation.
3. Always install sediment trap in gas supply line to prevent contamination of gas control.

The meter and service must be large enough to handle all the burners being installed plus any other connected load. When gas piping is not included in the layout drawing, the local gas supplier will usually help in planning the gas piping.

- ◆ Support all gas piping with suitable suspension materials and in accordance with local codes.
- ◆ Use wrought iron or wrought steel pipe and malleable iron fittings. All pipe and fittings should be new and free from defects. Ream the pipe ends and tubing ends to remove obstructions and burrs.
- ◆ Use LP-gas resistant joint compound on all threads. Apply only to male end of piping.

Check all piping, fittings, and connections for leaks before placing heating equipment into service. Use only soap and water solution for checking for gas leaks, NEVER use and open flame.

In industrial installations where the natural gas pressure at the meter is available at higher pressure than the standard 7" TO 14" W.C., it may be possible to cut down on gas piping costs (when local codes and the Fire Marshal approve) by running high pressure gas lines inside the building or on the outside of the building. In no case should the pressure exceed 10% of the service supply pressure. When using a high-pressure gas distribution system each heating zone should be equipped with a pounds to inches service regulator with soft seat, positive 100% lock-up.

Allowing high gas pressure on the downstream side of the regulator will damage the control valve in the gas train. The outlet pressure of the service regulators should be set at 7" W.C. for natural gas and 11" W.C. for LP gases/propane gases. If it is not practical to regulate in "zones", each burner may be equipped with its own regulator.

To meet the requirements of 100% positive lock-up and internal relief vent must be piped to the outside of the building. It is recommended that an intermediate service regulator, such as a Maxitrol 325 Series or approved equal be used.

The typical discharge pressure on the downstream side of the gas meter furnished by the gas company is usually 5 P.S.I.G. while the discharge pressure of the regulator on the propane tank is usually set at 15 P.S.I.G.

Sizing of low and high pressure piping distribution systems for natural gas should be made in accordance with the National Fuel Gas Code, ANSI Z223.1 (current standard) NFPA No. 54. Consult the supplier of the propane tank and vaporizing system for the sizing of the piping system for LP gas pipe work.

When leak testing the gas piping system, the Omega II® burners must be isolated from the gas piping system. High-pressure compressed air used in the leak test will damage the control valve in the burner gas train, which will result in unsafe operation of the burner(s). For proper and safe test procedures, observe the provisions of Part #4, of the National Fuel Gas Code, ANSI Z223.1 (current standard) - *Inspection, Testing and Purging* or refer to equivalent local. In Canadian see gas code CAN/CGA-B149.1- M91.

NOTE: It is important that the entire system, up to the burner gas connection, be checked for leaks, prior to start up.

GAS PIPE SIZING CHART

| NATURAL GAS | | | | | | | |
|---|-----------------------------|-----|-----|-----|------|------|------|
| Pipe Size | Total Length of Pipe (feet) | | | | | | |
| | 20' | 40' | 60' | 80' | 100' | 150' | 200' |
| 1/2" | 120 | 82 | 66 | 57 | 50 | 40 | 35 |
| 3/4" | 250 | 170 | 138 | 118 | 103 | 84 | 72 |
| 1" | 465 | 320 | 260 | 220 | 195 | 160 | 135 |
| 1-1/4" | 848 | 600 | 517 | 427 | 380 | 310 | 268 |
| 1-1/2" | 1316 | 931 | 801 | 661 | 588 | 480 | 416 |
| PIPE CAPACITY - MBTU/HR | | | | | | | |
| 1/2" W.C. P.D. WITH 7.0" SUPPLY PRESSURE | | | | | | | |

| LP / PROPANE GAS | | | | | | | |
|--|-----------------------------|------|------|------|------|------|------|
| Pipe Size | Total Length of Pipe (feet) | | | | | | |
| | 20' | 40' | 60' | 80' | 100' | 150' | 200' |
| 1/2" | 275 | 129 | 103 | 89 | 78 | 63 | 54 |
| 3/4" | 567 | 267 | 217 | 185 | 162 | 132 | 112 |
| 1" | 1071 | 504 | 409 | 346 | 307 | 252 | 209 |
| 1-1/4" | 2205 | 1039 | 834 | 724 | 630 | 511 | 439 |
| 1-1/2" | 3307 | 1559 | 1275 | 1086 | 976 | 787 | 665 |
| PIPE CAPACITY - MBTU/HR | | | | | | | |
| 1/2" W.C. P.D. WITH 11.0" SUPPLY PRESSURE | | | | | | | |

FLEXIBLE GAS CONNECTOR

⚠ WARNING

FIRE OR EXPLOSION HAZARD



IMPROPER INSTALLATION, ADJUSTMENT, ALTERATION, SERVICE OR MAINTENANCE CAN CAUSE DEATH, SEVERE INJURY AND/OR PROPERTY DAMAGE.

There is expansion of the radiant pipe with each firing cycle and this will cause the burner to move with respect to the gas line. This can cause an unsafe condition if the gas pipe connection is not done in strict accordance to the instructions.

United States - Use only the stainless-steel flexible gas connector as supplied by Combustion Research Corporation.

Canada – Use approved gas connector as outlined in B149 Codes; Type 1, minimum 36” long. See chart below for sizing. This hose is to be supplied by the installing contractor.

Install the flex connector as shown in the diagram below. This gas connector accommodates the normal expansion of the system. Before connecting the gas connector, verify that all high-pressure testing has been completed.

The gas connector shut off valve must be parallel to the gas inlet on the burner. A 2-3” (5-8 cm) cold displacement for initial setup is shown. This displacement may reduce when the system is fired.

- Do not high pressure test the gas piping with the burner connected. Failure to follow these instructions can result in property damage.
- Check the pipe and tubing ends for leaks before placing heating equipment into service. When checking for gas leaks, use a soap and water solution, never use an open flame. The loop of the gas flex **MUST BE** parallel or in line with the gas inlet pipe on the burner.
- The displacement as shown is for cold, non-firing condition. This displacement will vary as system heats up.
- Install drip leg in accordance with all applicable codes.
- **EXCESSIVE TORQUE ON THE BURNER GAS INLET MANIFOLD MAY CAUSE DAMAGE. ALWAYS USE TWO (2) WRENCHES WHEN MAKING PIPING CONNECTIONS TO THE BURNER. DO NOT APPLY PIPE DOPE TO FLARE NUT FITTINGS OF THE FLEXIBLE GAS CONNECTOR.**

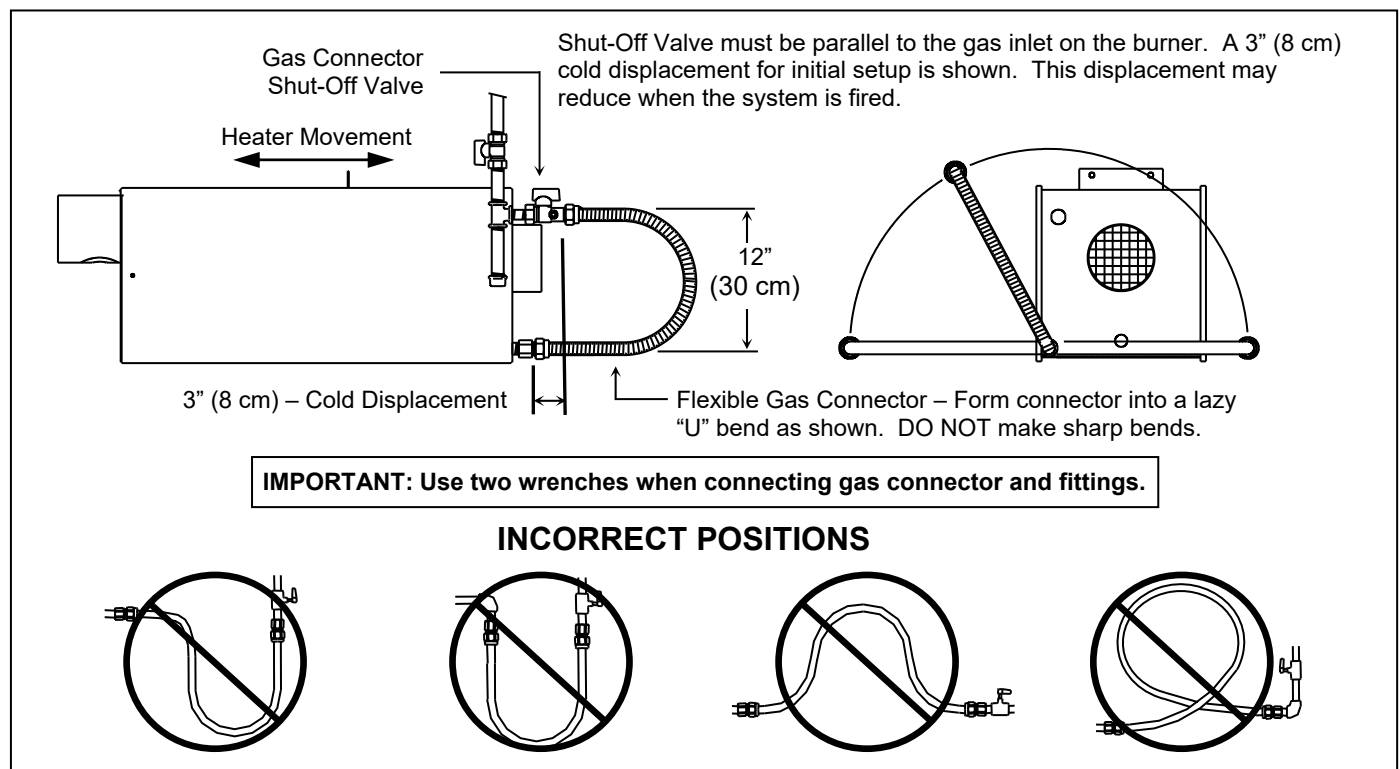

| Gas Connector Description | Used With Inputs of | P/N |
|---|---------------------|-----------------------|
| 1/2" Flexible Stainless-Steel Gas Connector (US Models) – 36" L | 30K through 150K | 0317.00 |
| 3/4" Flexible Stainless-Steel Gas Connector (US Models) – 36" L | 155K through 220K | 0417.00 |
| 1/2" Flexible Type 1 Rubber Hose (Canada Only) – 36" L | 30K through 175K | Supplied by Installer |
| 3/4" Flexible Type 1 Rubber Hose (Canada Only) – 36" L | 180K through 220K | Supplied by Installer |

GAS PRESSURE AT MANIFOLD

Natural Gas: 3.5" W.C. (High Fire)
 2.0" W.C. (Low Fire)
 LP Gas: 10.0" W.C. (High Fire)
 4.5" W.C. (Low Fire)
 1/2" NPT Gas Connector Size

ELECTRICAL RATING

120VAC, 60 Hz, 1.9 Amp

GAS INLET PRESSURE

Natural Gas: 4.5" W.C. Min. for inputs up to 150 MBH
 6.0" W.C. Min. for inputs of 155 to 175 MBH
 6.5" W.C. Min. for inputs of 180 to 220 MBH
 14.0" W.C. Maximum
 LP Gas: 11.0" W.C. Minimum, 14.0" W.C. Maximum

ALTITUDE

United States; 0 – 2,000 Ft. **(0 - 610 m)**
 Canada; 0 - 2,000 Ft. **(0 - 610 m)** Inputs of 180K thru 250k
 2,000 - 4,500 Ft. **(610 - 1,372 m)** Inputs of 40K thru 175k

RESIDEO 2-STAGE GAS VALVE

P/N 5285.5001 (NG) & 5285.5002 (LP)

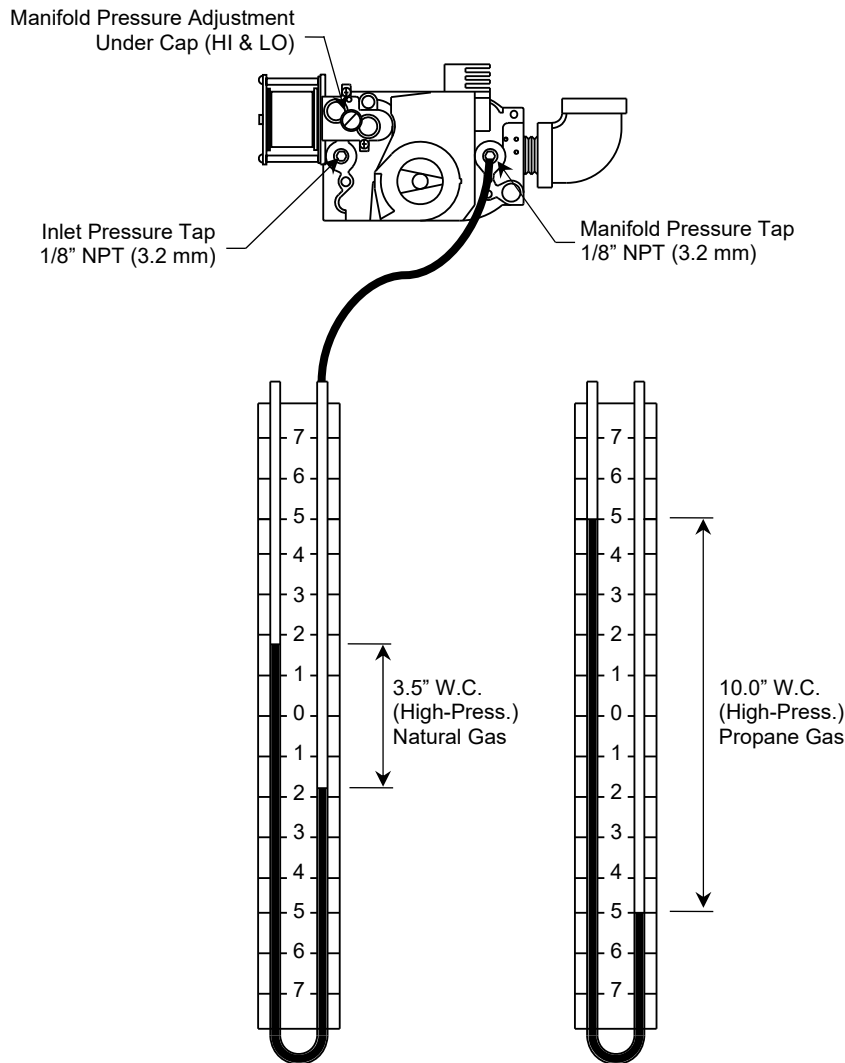

NOTE: Gas pressures must be measured with a water or red oil manometer - NOT A DIAL GAUGE. All measurements must be made when this heater and all other gas burning equipment connected to the gas supply system are operating at maximum capacity. It should be assured by test that the gas supply pressure at the burner inlet is at the minimum figures listed with a maximum inlet pressure of 1/2 lb. or 14.0" W.C.

The installer must provide a 1/8" N.P.T. (3.2mm) plugged tapping, accessible for test gauge connection, immediately upstream of the gas supply.

White Rodgers 2-STAGE GAS VALVE

P/N 5285.0901 (NG) & 5285.0902 (LP)

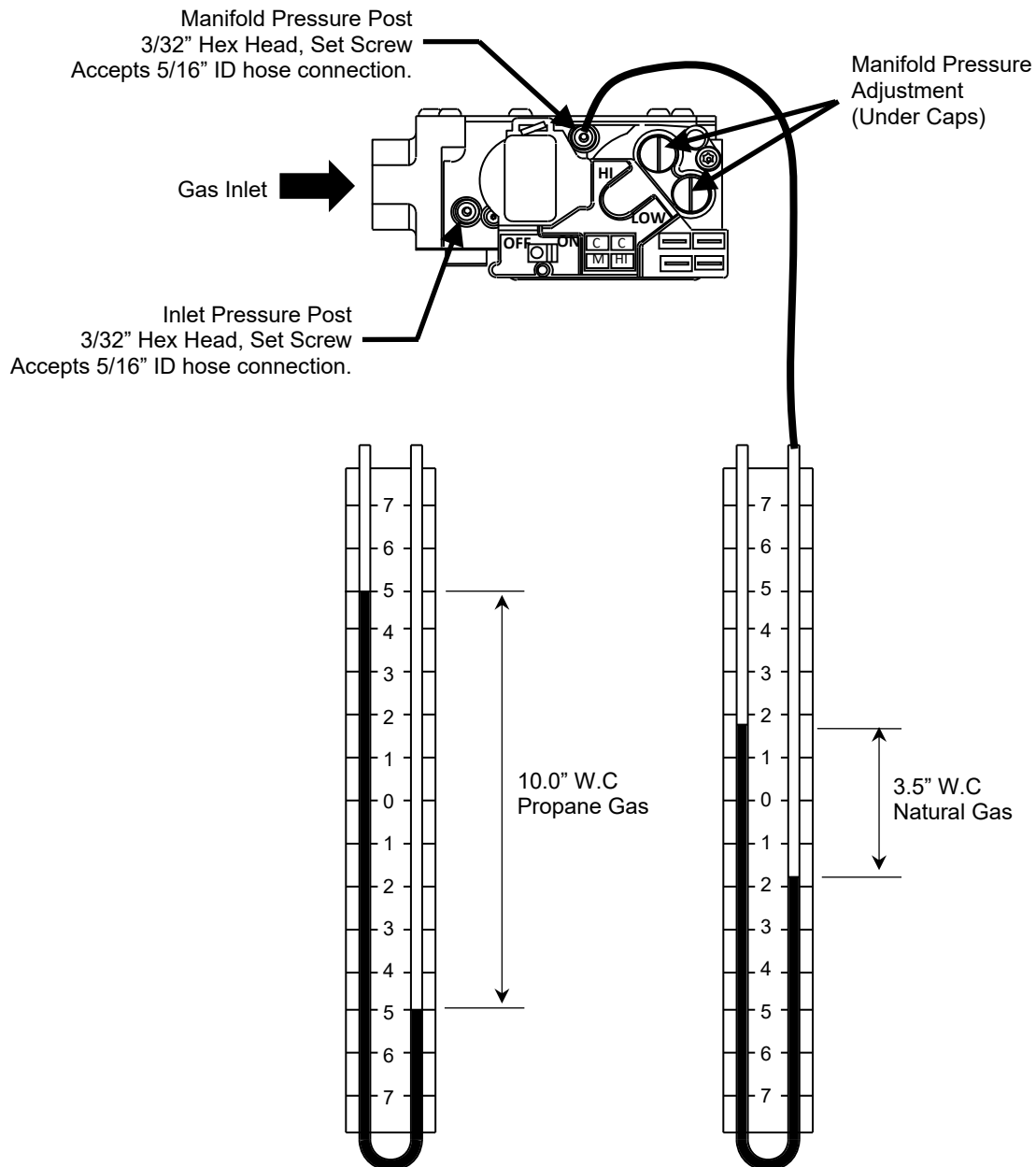

Loosen the Pressure Post set screw using a 3/32" hex Allen Wrench approximately 1 – 2 Counterclockwise turns. **DO NOT REMOVE SET SCREW.** Attach 5/16" ID hose to post. After test measurements ensure set screw is tightly closed.

NOTE: Gas pressures must be measured with a water or red oil manometer - NOT A DIAL GAUGE. All measurements must be made when this heater and all other gas burning equipment connected to the gas supply system are operating at maximum capacity. It should be assured by test that the gas supply pressure at the burner inlet is at the minimum figures listed with a maximum inlet pressure of 1/2 lb. or 14.0" W.C.

The installer must provide a 1/8" N.P.T. (3.2mm) plugged tapping, accessible for test gauge connection, immediately upstream of the gas supply.

COMBUSTION AIR SUPPLY

NOTICE

Air that is not contaminated must be ducted to the heater if chlorinated or fluorinated contaminants, high humidity, other contaminants, or if negative pressure is present in the area where the heater is installed.

1. Combustion air is a factory preset opening.
2. It is recommended that outside combustion air be used. However, combustion air may be drawn from the space that is being heated, PROVIDED the building does not have a negative pressure and the atmosphere is not contaminated with acid fumes, fluorocarbons, corrosive substances, dirt, oil, etc., which would have an adverse effect on the blower and radiant tubing. DO NOT draw combustion air from an attic space.
3. If outside air combustion air is not used and the room in which the heater is used is of a tight construction, provisions must be made for supplying combustion air. One square inch of free area opening for each 5,000 Btu/hr input is required to replenish the air used by the heating system.

OUTSIDE AIR SUPPLY (RECOMMENDED)

1. The outside air intake assembly (PN 0314.00) consists of: 1 - 4" (10 cm) OD inlet hood, 1 - 4" (10 cm) OD 24" (61 cm) long inlet flex and 2 clamps.

2. The assembly may be extended by adding up to 20' (6 m) of the appropriately sized ducting. A maximum of two elbows may be used. Insulating the ducting will stop condensation from forming on its exterior.
3. Air intake may be made through the roof using "mushroom" type vent cap.
4. Maintain a minimum of 6' (1.8 m) between the exhaust port and the fresh air inlet port.
5. When using a round vent cap for air inlet, maintain a minimum of 6" (15 cm) from the cap and the exterior wall.
6. DO NOT DRAW COMBUSTION AIR FROM ATTIC OR SIMILAR SPACE. DO NOT USE PLASTIC TYPE "DRYER" FLEX FOR THE COMBUSTION AIR INLET FLEX.
7. The air intake terminal must be located not less than 1' (31 cm) above grade.

NOTE –DO NOT install inlet flex as an elbow into the burner - system pulsation can occur.

On systems with a High Fire BTU input of 180,000 thru 220,000, the following shall apply;

- The 4" (10 cm) diameter combustion air ducting is limited to a 7' length with one 90° elbow (including the 24" (61 cm) long, 4" (10 cm) diameter inlet flex duct).
- Increase the hard duct size to 6" (16 cm) diameter for hard duct lengths exceeding 7' (2.1 m), up to 20' (6 m) in length. A maximum of 2, 6" (16 cm) diameter 90° elbows can be used.
- A 6" to 4" (16 cm to 10 cm) reducing fitting, supplied by the installer, shall be used to accommodate the 4" diameter flex connection into the burner combustion air inlet.

SIDE WALL PENITRATION (TOP VIEW)

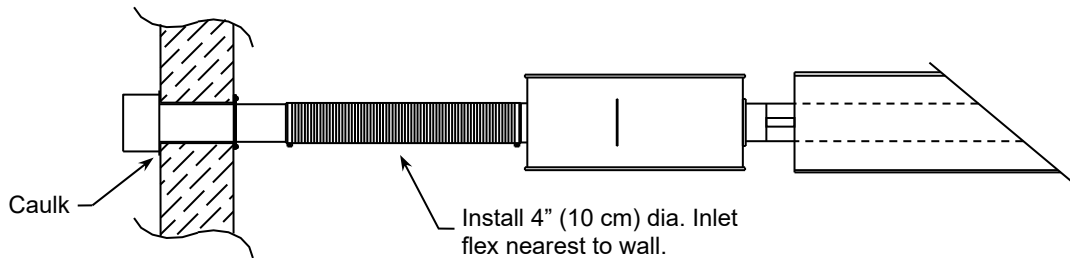

ROOF PENITRATION (SIDE VIEW)

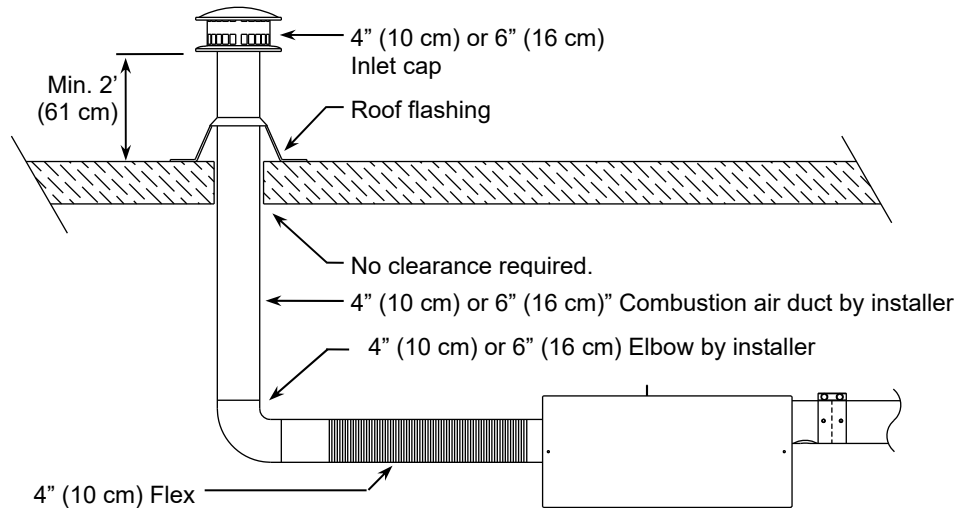

COMBUSTION AIR SUPPLY

When two *OMEGA II*® systems are controlled by one thermostat a common combustion air supply can be used.

- For BTU inputs up to 175 MBH this duct must be a minimum of 6" (15 cm) diameter and should not exceed 50' (15 m) in length.
- For BTU inputs of 180 MBH and higher this duct must be a minimum of 8" (20 cm) diameter and should not exceed 50' (15 m) in length.
- A Maximum of two (2) 90° elbows may be used.

- Maintain a minimum of 6' (1.8 m) between the exhaust port and the fresh air intake. Install 4" (10 cm) diameter flex nearest inlet trunk.
 - Do not install inlet flex as an elbow into the burner.
 - Install a minimum 18" (46 cm) straight length of duct into burner.
 - If condensation on the inlet duct is a problem, insulate the duct.
- Air intake may be made through the roof as well.

SIDE WALL COMBUSTION AIR SUPPLY

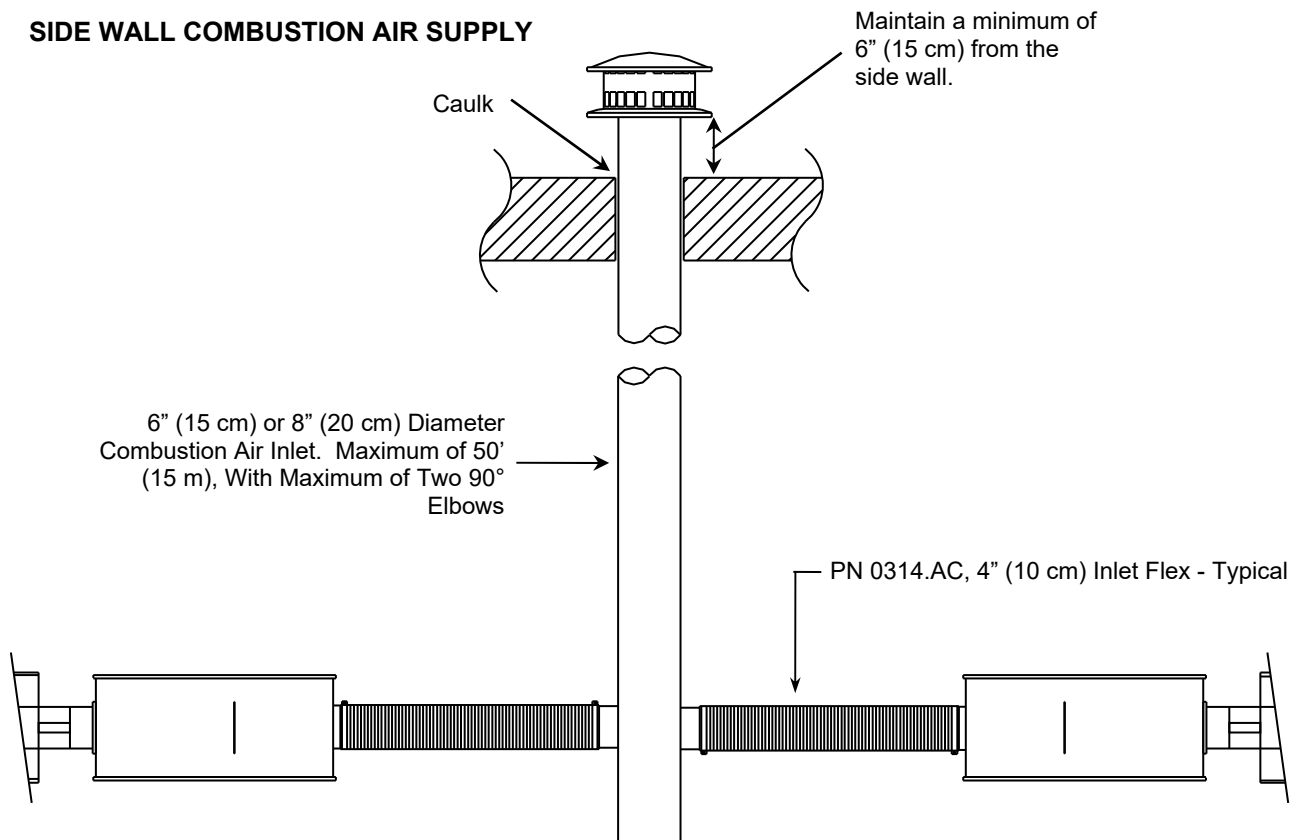

Both heaters must be controlled with one thermostat

VENTING**! WARNING****IMPROPER INSTALLATION CAN CAUSE DEATH, SEVERE INJURY AND/OR PROPERTY DAMAGE.**

Improper venting and insufficient ventilation may result in health problems, carbon monoxide poisoning and death. Vent enclosed spaces and buildings according to national, state, provincial and local codes.

This radiant heater must be vented in accordance with national, state, provincial and local codes, and the guidelines in this manual.

United States - Refer to the latest edition of the National Fuel Gas code NFPA 54/ANSI Z223.1

Canada - Refer to the latest edition of the Natural Gas and Propane Installation Code CSA B149.1

General Requirements

- ◆ Heater may be vented to the outdoors vertically or horizontally.
- ◆ The exhaust end of the heater will accept a 4" (10 cm) vent pipe.
- ◆ Maintain a minimum distance of 6" (15 cm) clearance around single wall vent pipe.
- ◆ Do not exceed a maximum vent length of 20 ft. (6 m).
- ◆ Avoid using more than two 90° elbows in the venting system. For each additional elbow, subtract 5 ft. (1.5 m).
- ◆ Use venting material that is corrosion resistant.
- ◆ Any section of the vent pipe that passes through a combustible wall or roof must have an approved thimble in accordance with codes.
- ◆ Avoid locating elbows in the first 3 ft. (90 cm) of vent pipe whenever possible. Maximum of two 90° Elbows.
- ◆ When sidewall venting, the vent cap must have a clearance of at least 3 ft. (1 m) above, to any building roof or overhang. Extend the vent beyond the building overhang if necessary.
- ◆ If condensation within the flue becomes a problem, the flue should be shortened or insulated.
- ◆ Because exhaust gases may cause degradation of building materials, the horizontal vent cap is to be installed at least 18" (46 cm) from the wall.
- ◆ A venting system shall terminate at least 2 ft. (61 cm) above the anticipated maximum snow accumulation.
- ◆ The heater may be individually vented or common vented. When venting horizontally, a maximum of two heaters can be commonly vented. Both heaters must be the same size and controlled with a single thermostat. Thermostat and heaters must be on the same circuit.
- ◆ When venting vertically, a maximum of four heaters can be commonly vented. Heaters must be the same size and controlled with a single thermostat. Thermostat and heaters must be on the same circuit.

United States Requirements:

- ◆ Vent must terminate at least 3 ft. (90 cm) above a mechanical air inlet located within 10 ft. (305 cm)
- ◆ Vent must terminate at least 4 ft. (122 cm) below, 4 ft. (122 cm) horizontally from, or 1 ft. (30 cm) above any window or door that opens, or gravity air inlet to a building.

Canadian Requirements:

- ◆ Vent shall not terminate within 6 ft. (1.80 m) of a mechanical air inlet.
- ◆ Vent shall not terminate within 3 ft. (0.9 m) of a window or door that can be opened, any non-mechanical air supply inlet to the building or to combustion air inlet of any other appliance.

Vent Category Definitions

'Category I' – A radiant tube heater that operates with a non-positive vent static pressure and with a vent gas temperature that avoids excessive condensate production in the vent.

'Category II' – A radiant tube heater that operates with a non-positive vent static pressure and with a vent gas temperature that can cause excessive condensate production in the vent.

'Category III' - A radiant tube heater that operates with a positive vent static pressure and with a vent gas temperature that avoids excessive condensate production in the vent.

'Category IV' - A radiant tube heater that operates with a positive vent static pressure and with a vent gas temperature that can cause excessive condensate production in the vent.

The *Omega II*® heaters can fall into either 'Category I' or 'Category III'. This manual will describe the installation requirements for each vent Category.

Unvented Operation

Sufficient ventilation must be provided in the amount of 4 cfm per 1000 Btu/h firing rate (United States); 3 cfm per 1000 Btu/h firing rate (Canada).

Any exhaust fans used to supply ventilation air must have an interlock switch with the heater that prevents the heater from operating when the exhaust fans are off. This can be accomplished with a pressure switch.

Use of outside combustion air is not recommended with unvented heaters.

Horizontal Venting ('Category III')

All horizontal venting is classified as 'Category III'.

Use an approved S636 or UL1738 'Category III' venting system **OR** single-wall vent pipe (min. 26 ga.) with all joints and seams sealed with a generous bead of heat resistant, pliable sealant such as high temp RTV silicone that is rated for temperatures up to 650°F (343°C) – supplied by others. Before placing the heater in operation, the installer must perform a leak test on the venting system using a soap and water solution.

A continuous section of type B-vent may only be used to pass through the exterior wall and outside of the building. Horizontal venting ('Category III') does not allow the use of type B-vent inside of the building.

Vertical Venting (Category I)

For 'Category I', vertical venting guidance, refer to the National Fuel Gas Code (ANSI Z 223.1, NFPA 54) in the USA and CSA B149.1 code in Canada. The following rules are found in these codes:

- A 'Category I' vent system is not required to be "gas tight" as the pressure inside the vertical vent system is a negative pressure.
- Type B vent material is acceptable for use in the vertical venting configuration. NOTE - It is recommended that single wall vent pipe be used up to the point of the roof penetration.
- The length of the horizontal run of the vent pipe must be less than 75% of the vertical run of the vent pipe.
Example: If horizontal vent section of the vent is 10 ft (3 m) long, the horizontal section of the vent must not exceed 7½ ft. (2.3 m) long.

- The vertical vent must terminate at least 5 ft (1.5 m) above the vent connection to the unit.
- Horizontal portion of the vent pipe can be double wall vent type B or single wall pipe type C and have an upward slope from the heater of at least 1/4" (6.35 mm) per foot (30 cm). When using type B-vent on horizontal section, use B to C adapter (field supplied) and attach to the exhaust end of heater tube.

NOTE: For all heaters with minimum radiant tube length, use single wall metal vent pipe within the building and an approved clearance roof thimble. Use B vent materials only for the section of vent passing through the roof and above the roof line. See illustration below. This method is recommended for all the radiant tube system lengths.

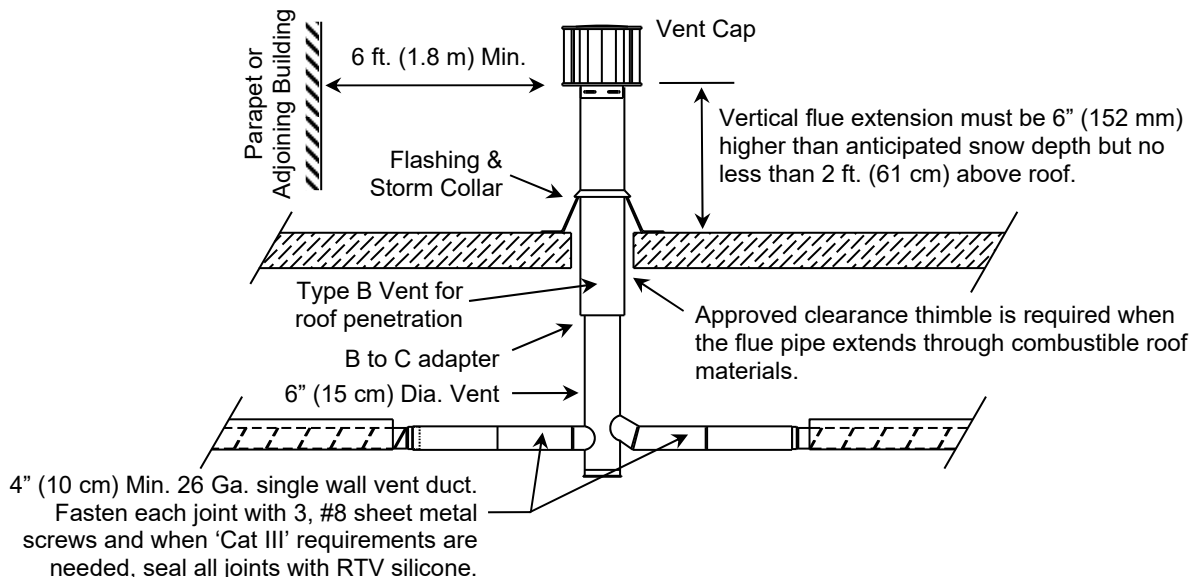
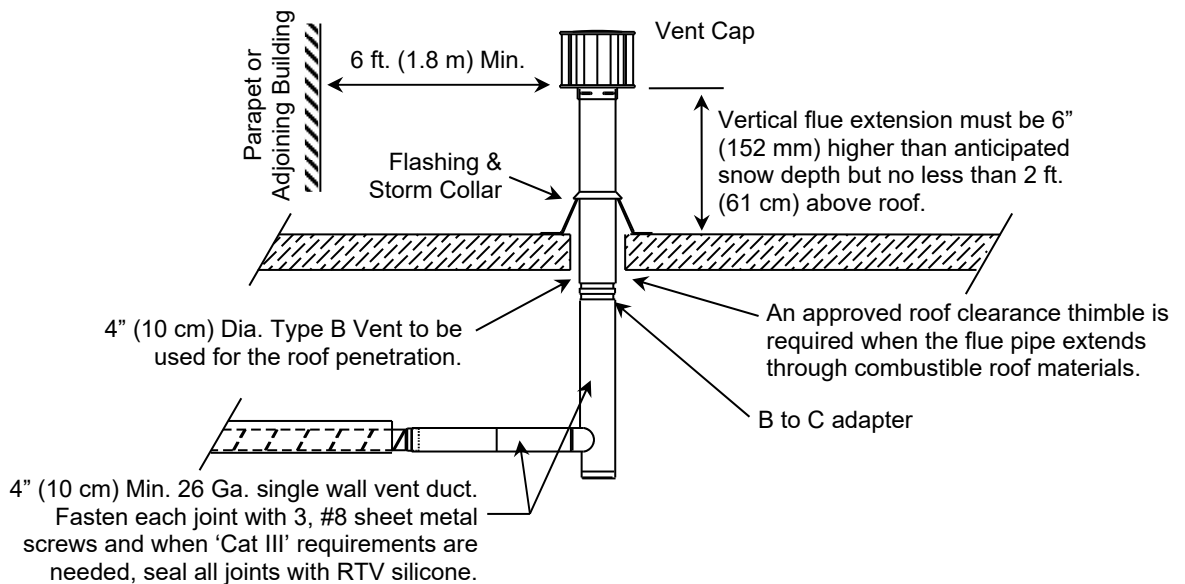

Horizontal Venting ('Category III')

Horizontally vented systems will operate as a positive vent static pressure. Use approved S636 or UL1738 'Category III' venting system **OR** minimum 26 ga., single-wall vent pipe made of corrosion resistant steel.

- Maximum of two heaters can be vented through a single side wall vent. Both heaters must be controlled by a single thermostat.
- Heaters must be of the same BTU input.
- Horizontal portion of the vent pipe to have a downward slope from the heater exhaust of at least 1/4" (6.35 mm) per foot (30 cm).
- A continuous section of B-Vent may only be used to pass through the exterior wall as 'Category III' venting does not allow type B-Vent inside the space.

When using single wall vent pipe, it is required that all vent pipes and connectors be fastened together with three (3) #8 sheet metal screws equally spaced per joint with all seams and joints sealed with a generous bead of high temp RTV silicone that is rated for temperatures up to 650°F (343°C) – supplied by others.

Once the silicone sealant has cured, the installer must perform a leak test on the complete venting system. A solution of soap and water should be used to test the venting system.

HORIZONTAL VENTING, NON-COMBUSTIBLE WALL

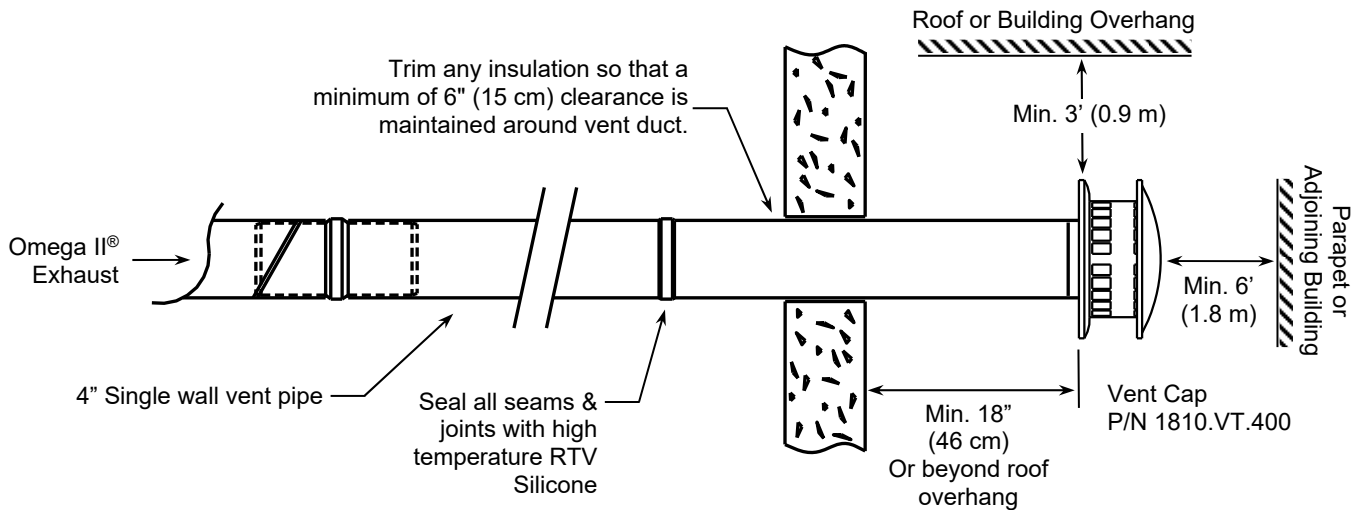

HORIZONTAL VENTING, COMBUSTIBLE WALL

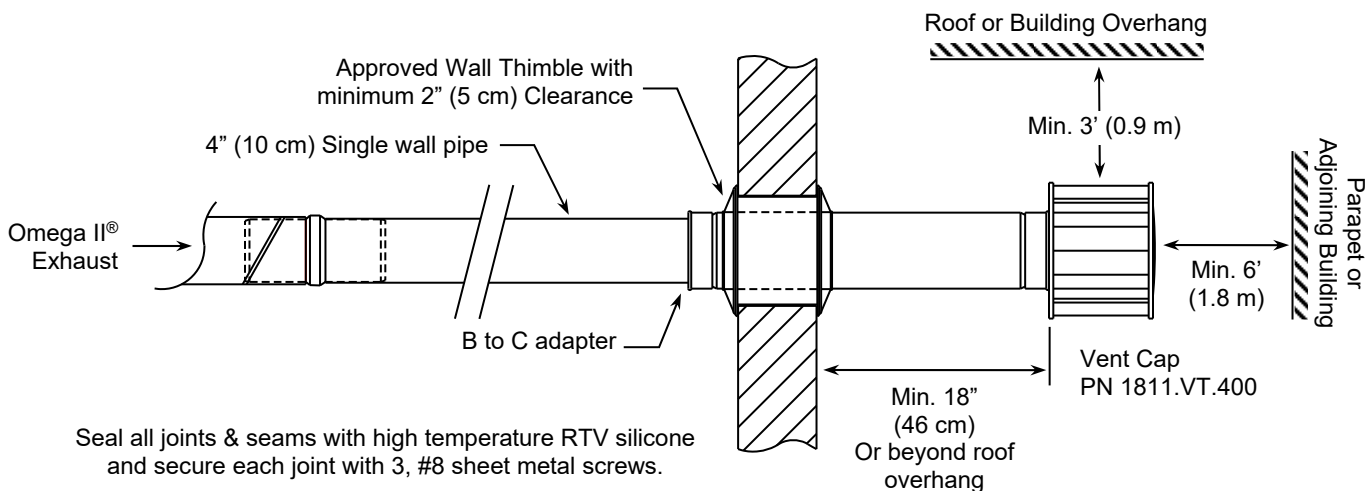

Note: A continuous section of B-vent may only be used to pass through the outside wall and outside of the building. 'Category III', horizontal venting does not allow the use of B-vent inside the space.

UNVENTED OPERATION

The OMEGA II® units are certified for un-vented operation. For proper ventilation, code requires that a positive air displacement of 4 CFM per 1000 BTU/Hr input of gas input for the U.S.A. and 3 CFM per 1000 BTU/Hr input of gas input for Canada be provided. This air displacement should be done mechanically and interlocked with the burner(s).

This will ensure that both the heaters and the ventilation operate simultaneously.

DO NOT USE UNVENTED SYSTEMS IN AGRICULTURAL APPLICATIONS.

NOTE:

On U-tube systems, install exhaust U return run on the right-hand side of the burner looking at the inlet of the burner. This allows for easy access to the controls compartment. Extend the vent diffuser 3 ft. (91 cm) past the heater air inlet.

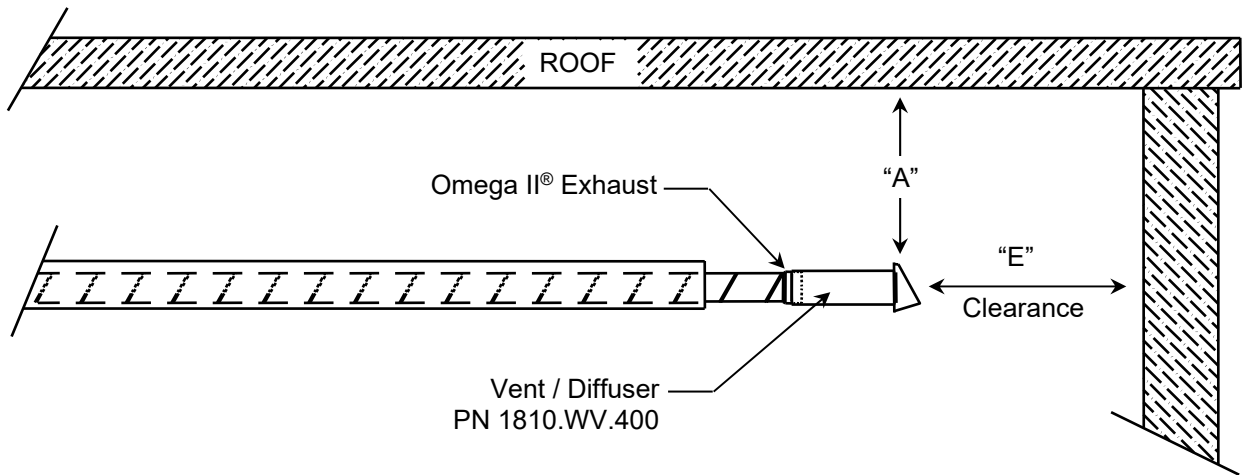

| MBH Input | A | E |
|-----------|-------------|-------------|
| 30 - 50 | 18" (45 cm) | 18" (45 cm) |
| 55 - 75 | 18" (45 cm) | 18" (45 cm) |
| 80 - 100 | 20" (51 cm) | 20" (51 cm) |
| 105 - 125 | 20" (51 cm) | 20" (51 cm) |
| 130 - 150 | 20" (51 cm) | 24" (61 cm) |
| 155 - 175 | 20" (51 cm) | 24" (61 cm) |
| 180 - 200 | 20" (51 cm) | 28" (71 cm) |
| 205 - 220 | 20" (51 cm) | 28" (71 cm) |

A "Straight Tube" system is shown above. On "U Tube" systems, install exhaust vent diffuser on the right-hand side of the burner looking at the inlet of the burner and extend a minimum of 3' (91 cm) past the end of the burner air inlet.

NOTE: DO NOT USE UN-VENTED SYSTEMS IN AGRICULTURAL APPLICATIONS

ELECTRICAL SUPPLY

The requirements and practices described below are based on the National Electrical Code ANSI/NFPA No. 70 (current standard) and the Canadian Electric Code. Although the requirements are uniform throughout the country, local electrical codes may deviate from the National Electrical Code and the Canadian Electric Code, therefore, local inspection authorities should be consulted regarding local requirements.

WARNING

ELECTRICAL SHOCK

DANGER OF SEVERE INJURY OR DEATH

Field wiring to the heater and vacuum exhauster must be connected and grounded in accordance with national, state, provincial, local codes and to the guidelines outlined in this manual. In the United States refer to the most current revisions to the ANSI/NFPA 70 Standard and in Canada refer to the most current revisions to the CSA C22.1 Part I Standard.

BURNER ASSEMBLY

Safety control circuits must be a two-wire circuit with a separate earth ground and have a nominal voltage not exceeding 125 volts. A safety control or protection device must be connected to interrupt the ungrounded conductor. Install a service disconnect within 3' (0.9 m) of the **OMEGA II® Burner Assembly**.

The **OMEGA II® Burner Assembly** shall be connected to a power supply branch circuit fused at not more than the value appropriate for the rating of any control or device included in the circuit.

Each **OMEGA II® Burner Assembly** electrical requirement is 1.9 FLA amps at 120V, 60 Hz. **DO NOT RUN THE ELECTRICAL SUPPLY LINES DIRECTLY ABOVE THE REFLECTOR OR BELOW THE REFLECTOR - CLEARANCE TO COMBUSTIBLES MUST BE MAINTAINED.**

NOTE: If any of the original wire as supplied with the appliance must be replaced, it must be replaced with wiring material having a temperature rating of at least 90°C.

Field wiring having a minimum rating of at least 90°C shall be used and supply circuit wiring shall have a minimum size of 14 AWG.

Large enough wire must be used in connecting to the **OMEGA II® Burner Assembly**. This is necessary for two reasons: 1) carrying capacity and 2) voltage drop. The wire size necessary to provide carrying capacity without over heating is determined by electrical codes which specify a minimum wire size for the amperage used. Most electrical supply problems are caused by voltage drop due to long runs, or low voltage supplied by the utility.

The correct size wire should be carefully selected before the installation is made. The first step is to establish what voltage will be supplied by the utility. This will vary across the country and should be verified by the utility and by actual measurement of the supply voltage prior to installation. The following chart shows maximum wire lengths which will keep the voltage drop to a minimum of 10% at various currents at 120V. Only copper wiring should be used.

WIRE LENGTH FOR 10% VOLTAGE DROP IN FEET - 120V 60HZ

| AMPERES | COPPER WIRE SIZE | | | |
|---------|------------------|-------|-------|-------|
| | No.14 | No.12 | No.10 | No. 8 |
| 15 | 150 | 225 | 350 | 600 |
| 20 | 110 | 175 | 275 | 450 |
| 25 | 90 | 140 | 225 | 350 |
| 30 | 75 | 125 | 150 | 300 |
| 35 | - | 100 | 135 | 250 |
| 40 | - | 85 | 125 | 225 |
| 45 | - | - | 110 | 200 |
| 50 | - | - | - | 175 |

INTERNAL WIRING DIAGRAM

**POINT TO POINT WIRING DIAGRAM
DUAL INPUT - SINGLE SPEED BLOWER**

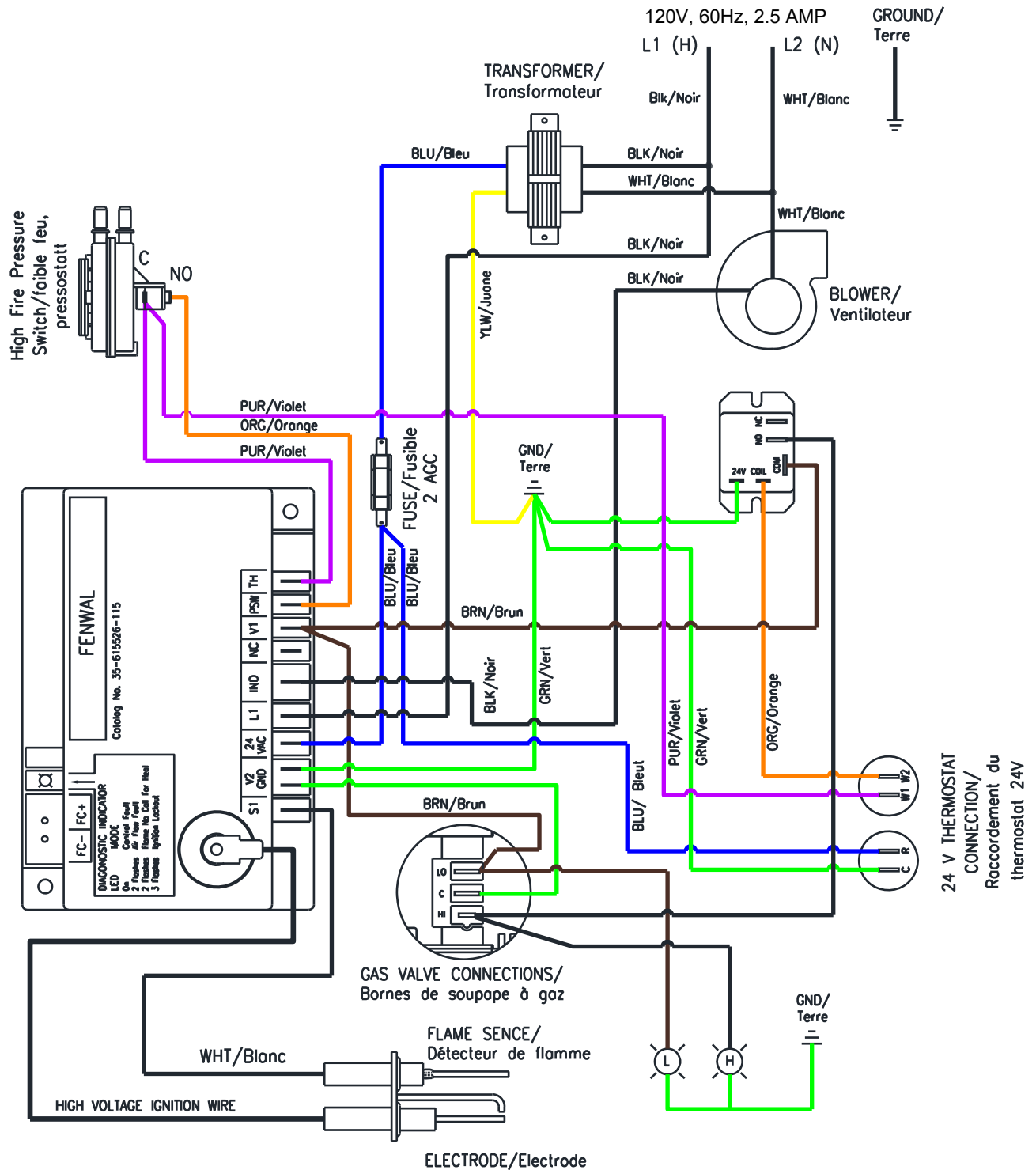

LOW VOLTAGE THERMOSTAT WIRING – ONE OR TWO HEATERS

The thermostat terminals are located next to the blower assembly. To access, remove the control compartment cover. Route the thermostat cable through the rear back plate. On the Omega II® DS and DW series heaters, a sealed strain relief fitting is provided for passing the thermostat cable through.

- Use 18/4 solid, class 2, thermostat cable (Red, White, Black & Green) between the thermostat and heater #1 terminals.
- Use 18/3 solid, class 2, thermostat cable (Red, White & Green) between the thermostat and heater #2 terminals.

- Maximum length of the 18 Ga. (0.8 mm²) cable is 100 ft. (30.5 m).
- Connect no more than two heaters to one thermostat. See the wiring information for three or more heaters controlled with one thermostat.
- DO NOT connect the thermostat wire to the “R” terminal of the second heater.

The following diagram shows the typical field wiring requirements for the heater(s).

SINGLE BURNER THERMOSTAT WIRING

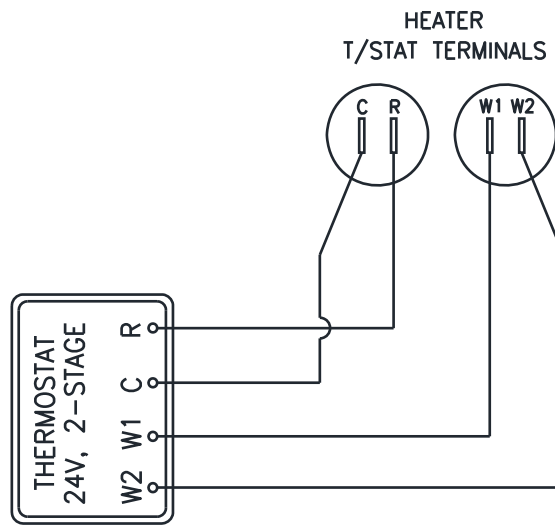

TWO BURNER THERMOSTAT WIRING

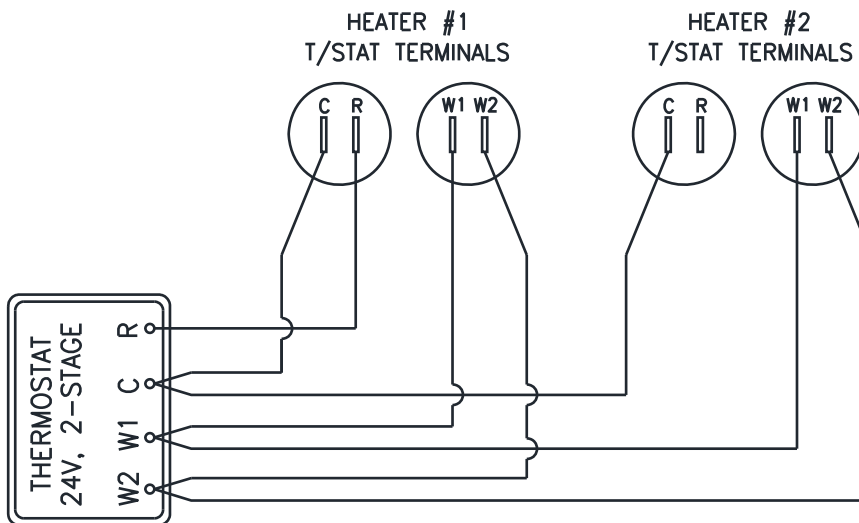

DO NOT connect the thermostat wire to the “R” terminal of the second heater.

WIRING FOR THREE OR MORE HEATERS CONTROLLED WITH ONE THERMOSTAT

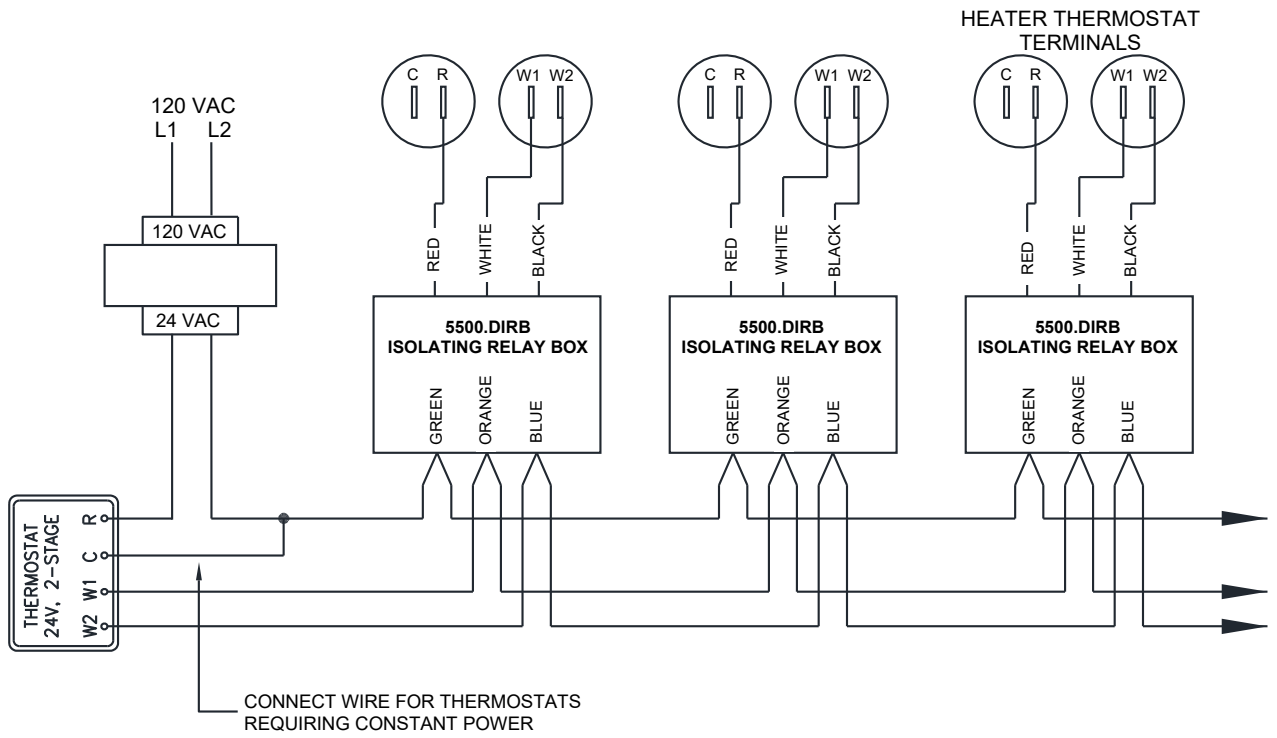

GENERAL SAFETY INFORMATION

Follow all local electrical and safety codes, as well as the National Electrical code (NEC) and the Occupational Safety and Health Act (OSHA).

1. *OMEGA II® BURNER ASSEMBLY* must be securely and adequately grounded.
2. Always disconnect power source before working on or near a motor or its connected load. If the power disconnect point is out of sight, lock it in the open position and tag to prevent unexpected application of power.
3. Be careful when touching the exterior of an operating motor -- it will be hot enough to be painful or cause injury. With modern motors, this condition is normal when operating at rated load and voltages -- these motors are built to operate at higher temperatures.
4. Protect the power cable from coming in contact with sharp objects.
5. Do not kink the power cable and never allow the cable to come in contact with oil, grease, hot surfaces, or chemicals.
6. Make certain that the power source conforms to the requirements of your equipment.
7. When cleaning electrical or electronic equipment, always use an approved cleaning agent such as dry cleaning solvent.
8. This is not an explosion proof burner. Do not use where explosive fumes or gases are present.

OPERATION

Before connecting the system to the electric supply, check the electrical characteristics as indicated on the Rating/ Nameplate to insure proper voltage.

With the air system in full operation and all ducts attached, measure current input to the motor and compare with the nameplate rating to determine if the motor is operating at safe load conditions and not overloaded.

RADIANT TUBING CHECK

1. Inspect entire network of radiant tubing to ensure that all fittings are securely screwed together.
2. Inspect entire network of radiant tubing to ensure that system is straight and assembled in a good workmanship manner.

PRECONDITIONS TO BE CHECKED BEFORE BURNER SYSTEM STARTUP

1. System has been installed as outlined in Installation Manual and nameplate data.
2. The system must be installed with adequate clearance to combustibles as outlined in this manual. In storage areas where stacking of materials may occur, the installer must provide signs which specify the maximum stacking height so as to maintain the required clearance to combustibles. A sample sign can be found at the end of this manual. Self-adhesive labels can be obtained

thru your sales representative or by contacting the factory.

3. Electrical input to building. It must provide a minimum service requirement for each heating zone as follows: 15 amp service, 120V AC/60 Hz (1-ph.). Check total system amperage requirements for proper service requirements.
4. NATURAL GAS SERVICE
 - a. Meter and pipe work to be adequate size for total building requirements
 - b. 1020 Btu/ft³ observe the minimum and maximum supply pressure as outlined in the technical data section of this manual.
5. Propane Service
 - a. Storage tanks should be large enough to vaporize required maximum load of the installed heating equipment.
 - b. Vaporizer system and high-pressure regulators system installed as required and set at 13.5 W.C. outlet.
 - c. 2500 Btu/ft³ at minimum of 11.0" at input side of regulator on burner during operation.
6. All gas valves in meter house and service cocks open. All feed lines have been purged of air.
7. When high pressure gas supplies are used, make sure the proper regulators and manual valves have been installed properly.
8. Combustion air and exhaust connections have been installed and are secure.

TO START SYSTEM

WARNING

FIRE OR EXPLOSION HAZARD

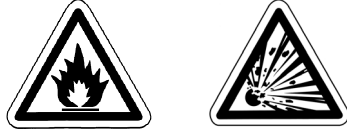

FIRE OR EXPLOSION HAZARD. CAN CAUSE DEATH, SEVERE INJURY AND/OR PROPERTY DAMAGE.

It is the installer's final responsibility to verify correct gas usage.

Do not use a gas control set for Natural Gas on LP or a gas control set for LP Gas on Natural Gas.

1. Check to ensure that main gas cock from meter is open. Check burner to ensure that gas cock is open.
2. Turn the main power switch ON and check fuse.
3. Set the thermostat higher than the existing temperature of the area to be heated. The following step should take place automatically:

The blower is powered and will start. The air flow switch closes and supplies power to the burner control. After the pre-purge time, the ignition control will produce the spark ignition as well as opening the gas valve allowing gas flow. The gas will then ignite.

4. Verify the heater is operating.
5. At this time, manually shut off the gas and verify that the "flame failure shutdown" occurs. Open the manual gas valve and turn off the power to the **OMEGA II® BURNER ASSEMBLY** to reset the control.
6. Set the thermostat down to the desired temperature.

NOTE - When the heater is initially fired, solvents or any oil that is on the radiant tube and fittings will burn off and may form a light haze in the building which can best be removed by the ventilation system in the building, or by opening the doors. This is a one-time problem and will not recur.

SEQUENCE OF OPERATION

1. When the thermostat calls for heat, the control will activate the blower motor.
2. When the motor approaches nominal running RPM, the pressure switch closes which activates the ignition module.
3. After a pre-purge cycle, the ignition module will then open the gas valve and energizes the spark igniter.
4. When the flame is established, the sparking sequence ceases.
5. If the flame is not established during the 10 second trial for ignition sequence, the ignition module closes the gas valve and a 15 second inter-purge begins. Module will try 2 additional times for ignition (with purge in between trials). If ignition is not established, the module will lockout for one hour (or until reset). After this one-hour

period, the ignition module re-attempts the full ignition sequence.

6. If the flame extinguishes during operation, the ignition module will attempt the multiple trial sequence outlined in step 5. If ignition is not re-established, the module will lockout for one hour or until reset.
7. After lockout, the control can be reset by turning down thermostat for five seconds, and then raising it again to desired temperature, or by disconnecting power and then reconnecting.
8. After the thermostat is satisfied, the power is removed from the ignition control and the blower post purge cycle begins. After 15 seconds, the blower shuts down.
9. System waits for the next call for heat.

RESETTING THE IGNITION CONTROL

If your burner should lock out, reset by the following method:

1. Turn off the disconnect switch located near the burner or turn down the thermostat to stop the entire system.
2. Turn the power back on and/or turn the thermostat back up.
3. The system will now automatically recycle on the thermostat to maintain desired room temperature.

IF THE BURNER WILL NOT LIGHT AFTER TWO RESET TRIALS, CONTACT YOUR INSTALLER FOR SERVICE.

NOTE: Controls are shipped with the gas control knob/switch in the ON position.

WARNING

FIRE OR EXPLOSION HAZARD



FIRE OR EXPLOSION HAZARD. CAN CAUSE DEATH, SEVERE INJURY AND/OR PROPERTY DAMAGE.

1. Do not force the gas control knob. Use only your hand to turn the gas control knob. Never use tools.
2. If the gas control knob will not operate by hand, a qualified service technician should replace the gas control.

STOPPING THE SYSTEM FOR SERVICE

1. For servicing an individual **OMEGA II® BURNER ASSEMBLY**, turn off the disconnect switch which should be mounted within arm's reach of the unit. Close the gas supply to the burner at the individual burner gas cock.
2. To service the thermostat, turn off the electrical power at the main power disconnect box.
3. Before servicing any gas component, shut off the gas supply line.

CHECK SAFETY SHUTDOWN PERFORMANCE

NOTE: Read steps 1-7 below before starting safety shutdown or safety lockout tests for the direct ignition (DI) module.

1. Turn gas supply off.
2. Set the thermostat or controller above room temperature to call for heat.
3. Watch for ignition spark following pre-purge. See ignition module specifications.
4. Time the length of ignition operation. See DI module specifications.
5. After the module locks out, open gas control and ensure there is no gas flow to main burner.
6. Set the thermostat below room temperature and wait one minute.
7. Operate system through one complete cycle to ensure all controls operate properly.

⚠ WARNING

ELECTRICAL SHOCK



DANGER OF SEVERE INJURY OR DEATH

ALWAYS DISCONNECT POWER SUPPLY BEFORE SERVICING THE BLOWER OR WORKING WITH THE UNIT FOR ANY REASON. THIS IS ESPECIALLY IMPORTANT WITH UNITS EQUIPPED WITH AUTOMATIC THERMAL RESET PROTECTION. UNIT MAY ACTIVATE WITHOUT WARNING!

GENERAL AND YEARLY MAINTENANCE

At regular intervals or at least once a year the entire system should be inspected.

OMEGA II® BURNER ASSEMBLY:

The gas connecting flex should be inspected for any cracks or breaks. Use a soap solution on the gas flex and gas piping to verify any leaks. **DO NOT USE OPEN FLAME FOR LEAK TEST.**

Check combustion air inlets and connecting duct work for obstructions and breakage; repair as needed.

Inspect hanging hardware, such as chains, for wear. If any wear is present, the system must not be operated until the chain(s) or associated hardware has been replaced.

Look for any deterioration in the heater housing assembly. Replace or repair as may be needed.

Radiant Tubing:

⚠ WARNING

FIRE OR EXPLOSION HAZARD



FIRE OR EXPLOSION HAZARD. CAN CAUSE DEATH, SEVERE INJURY AND/OR PROPERTY DAMAGE.

Damaged or nonconforming radiant tubing must be replaced with appropriate product as manufactured by Combustion Research Corporation.

The radiant tubing should be inspected at the beginning of every heating season. Look for cracks, holes, physical damage, etc. Replace as needed.

NOTE:

Use only approved **OMEGA II®** radiant tubes which are specifically manufactured for the **OMEGA II®** system. Use of substitute materials can result in an unsafe condition and will void any and all warranties.

DIAGNOSIS AND TESTING OMEGA II® BURNER ASSEMBLY:

IF THE BURNER DOES NOT OPERATE, A "SYSTEM CHECK" MUST BE MADE AS FOLLOWS:

SYSTEM CHECK

⚠ WARNING

FIRE OR EXPLOSION HAZARD



FIRE OR EXPLOSION HAZARD. CAN CAUSE DEATH, SEVERE INJURY AND/OR PROPERTY DAMAGE.

Perform the safety shutdown test any time work is done on a gas system.

1. Check for proper installation of unit (refer to owner's manual). If power is not present, check the power supply to input terminals with AC voltmeter and check fuse in burner box.
2. Remove tube fitting from air switch and insert new fitting with short rubber hose attached. Normally open air flow switch can be operated with a slight mouth vacuum to check performance. If air flow switch does not close under normal operation, verify there are no obstructions in the air inlet and vent and replace air flow switch.
3. Provided air flow switch is operating, listen for high voltage arc, an audible spark "ticking." **(DO NOT**

TOUCH IGNITION OUTPUT LEADS OR IGNITION ELECTRODES.) Check to see if high voltage leaks occur at porcelain and high voltage leads.

4. If ignition arc is not present or sporadic, turn off power and check gap. It should be approximately 0.10 inch (2.5 mm). **(DO NOT TRY TO MEASURE HIGH VOLTAGE OUTPUT.)** High voltage wire should not touch casing as grounding can occur.
5. If ignition wires and electrodes are set as above, and power is present, but ignition arc does not occur, the ignition assembly is defective, and the ignition control should be replaced.
6. Remove gas jet, inspect for possible obstruction or incorrect orifice size.
7. Disconnect power and check terminals to be sure that there are no loose spade connections or broken wires.

ELECTRONIC PROVEN SPARK IGNITION CONTROL WITH 100% LOCKOUT

APPLICATION

The solid-state ignition control will ignite the gas by spark. The gas is ignited and burns during each running cycle.

Should a loss of flame occur, the main valve closes and a retry for ignition will commence. This control has an internal 100% lockout function to completely shut down the system should the gas fail to ignite within 10 seconds. To initiate a re-ignition trial when lockout occurs, the power must be interrupted for 1 minute.

The solid-state ignition control must not be subjected to temperatures below -40°F (-40°C) or above 150°F (66°C).

IGNITION CONTROL DIAGNOSTIC LIGHT CODES:

- **Steady On** – Internal Control Fault
- **1 Flash** – Air Flow Fault
- **2 Flashes** – Flame No Call For Heat
- **3 Flashes** – Ignition Lockout

GAS SUPPLY FAILURE ON START

1. Thermostat calls for heat.
2. Air flow is proven.
3. Valve and spark are energized after pre-purge.
4. After a 10 second trial for ignition, the system will lockout to completely disarm the system.
5. In order to initiate a re-ignition trial, the power must be interrupted for 5 minutes.

POWER INTERRUPTION ON START

1. No gas will flow during power interruption.
2. Normal sequence will resume when power is restored.

POWER INTERRUPTION DURING RUNNING CYCLE:

1. Valve is de-energized.

2. Valve and spark are energized when power is restored, and normal sequence will resume.

TURNING OFF THE APPLIANCE

VACATION SHUTDOWN -- Set the thermostat to the desired room temperature while you are away.

COMPLETE SHUTDOWN – Turn gas supply off at the burner assembly. Follow the Lighting Procedures listed to resume normal operation.

STOP: READ ALL WARNINGS

The flame is lit automatically. If the appliance does not turn on when the thermostat is set several degrees above room temperature, follow these instructions:

1. Set the thermostat to its lowest setting to reset the safety control.
2. Disconnect all electric power to the appliance.
3. Remove the control access panel.
4. Turn gas control knob/switch the OFF position, **DO NOT FORCE.**
5. Wait 5 minutes to clear out any unburned gas. If you then smell gas, **STOP!** Follow Step 3 in the following Warning statement. If you do not smell gas, continue with the next step.
6. Turn the gas control knob/switch to the ON position.
7. Replace the control access panel.
8. Reconnect all electric power to the appliance.
9. Set the thermostat to the desired setting.
10. If the appliance does not turn on, shut the gas supply to the burner off and contact a qualified service technician for assistance.

! WARNING**FIRE OR EXPLOSION HAZARD**

IMPROPER INSTALLATION, ADJUSTMENT, ALTERATION, SERVICE OR MAINTENANCE CAN CAUSE DEATH, SEVERE INJURY AND/OR PROPERTY DAMAGE.

1. Flame is lit automatically. Do not light the flame manually.
2. Before lighting burner flame, smell around the appliance for gas. Be sure to smell next to floor because LP gas is heavier than air.
3. IF YOU SMELL GAS:
 - ◆ Turn off the gas supply at the appliance service valve. On LP gas systems, turn off gas supply at the gas tank.
 - ◆ Do not light any appliances in the house.
 - ◆ Do not touch electrical switches or use the phone.
 - ◆ Leave the building and use a neighbor's phone to call your gas supplier.
 - ◆ If you cannot reach your gas supplier, call the fire department.
4. Do not force the gas control knob. Use only hand pressure to operate the gas control knob/switch. Never use any tools. If the gas control knob/switch will not operate by hand, a qualified service technician should replace the gas control. Force or attempted repair may result in a fire or explosion.
5. The gas control must be replaced in the case of any physical damage, tampering, bent terminals, missing or broken parts, stripped threads, and evidence of exposure to heat.

MAINTENANCE

Regular preventive maintenance is important in applications that place a heavy load on system controls, such as in the commercial cooking and agricultural and industrial industries because:

1. In applications where the equipment operates 100,000-200,000 cycles per year. Such heavy cycling can wear out the gas control in one to two years.
2. Exposure to water, dirt, chemicals, and heat can damage the gas control and shut down the control system.

NOTICE

Do not apply a jumper across or short the valve coil terminals. Doing so will damage the ignition module.

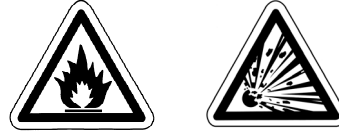
! WARNING**FIRE OR EXPLOSION HAZARD**

IMPROPER INSTALLATION, ADJUSTMENT, ALTERATION, SERVICE OR MAINTENANCE CAN CAUSE DEATH, SEVERE INJURY AND/OR PROPERTY DAMAGE.

Do not disassemble the gas control. The gas control contains no replaceable components. Attempted disassembly or repair may damage the gas control.

The maintenance program should include regular checkout of the gas control. Maintenance frequency must be determined individually for each application. Some considerations are:

1. **Intermittent use.** Appliances that are used seasonally should be checked before shutdown and again before the next use.
2. **Consequence of unexpected shutdown.** Where the cost of an unexpected shutdown would be high, the system should be checked more often.
3. **Dusty, wet or corrosive environment.** Since these environments can cause the gas control to deteriorate more rapidly, the system should be checked more often.

The gas control should be replaced if:

1. It does not perform properly on checkout or troubleshooting.
2. The gas control knob/switch is hard to turn or push down, or it fails to pop back up when released.
3. The gas supply pressure was tested or operated at more than 14.0" W.C.

CHECKOUT PROCEDURE

Before leaving installation, several complete operating cycles should be observed to see that all components are functioning properly.

1. Before turning on the main electrical power switch, be sure all gas supply lines are purged of air.
2. Close main manual shutoff valve and wait for 5 minutes, then turn "A" valve to counterclockwise  to "ON" position.
CAUTION: Check for positive gas seal using soap solution on valve inlet and all upstream pipe connections.
3. Turn on main electrical power switch and close thermostat contacts.
4. After the control is powered, it will automatically energize the spark and the gas valve.
5. The sensing probe detects the presence of the low fire flame and the control de-energizes the spark and the valve will remain open. Check valve outlet and other downstream pipe connections with a soap solution.

6. Turn the thermostat to a lower setting to open contacts. The main gas flame should be extinguished. The blower post purge cycle will begin.
7. For 100% shutoff check, set thermostat to low dial setting (system off). Disconnect sensing probe lead at flame sensor terminal.
8. Turn the thermostat up to energize control, After pre-purge the spark ignition and gas valve will be energized. The gas should ignite, if it does not ignite, after 10 seconds, the spark and gas valve will close. The control will initiate inter-purge cycle and will energize the spark and gas valve again and will sequence a third time before lockout occurs (no gas flow, no spark).
9. Set the thermostat to desired room temperature to put the system back in service.

CHECK SAFETY SHUTDOWN PERFORMANCE

! WARNING

FIRE OR EXPLOSION HAZARD



IMPROPER INSTALLATION, ADJUSTMENT, ALTERATION, SERVICE OR MAINTENANCE CAN CAUSE DEATH, SEVERE INJURY AND/OR PROPERTY DAMAGE.

Perform the safety shutdown test anytime work is done on a gas system.

NOTE: Read steps 1-7 below before starting safety shutdown or safety lockout tests for the ignition module.

1. Turn gas supply off.
2. Set the thermostat or controller above room temperature to call for heat.
3. Watch for ignition spark immediately or following pre-purge. See ignition module specifications.
4. Time length of ignition operation. See ignition module specifications.
5. After the module locks out, open gas control and ensure there is no gas flow to main burner.
6. Set the thermostat below room temperature and wait one minute.
7. Operate system through one complete cycle to ensure all controls operate properly.

IGNITION CHECKOUT PROCEDURES

A combination voltmeter and micro-ammeter with a DC micro-ammeter range setting of 0 to 10 micro-ampere is required. Follow meter instructions for proper use.

TO CHECK AC VOLTAGES:

1. Set range selection switch to 150V AC before connecting leads.
2. Connect wire leads in parallel with voltage to be measured.
3. Read voltage on AC scale.

TO CHECK CURRENT FROM FLAME SENSING PROBE:

1. Set range selector switch to 10 micro-amperes before connecting leads.
2. Turn off power supply to ignition control.
3. Disconnect sensing probe cable from sensor terminal or ignition control.
4. Connect red (positive) meter lead to sensor terminal.
5. Connect black (negative) meter lead to probe cable.
6. Turn on electrical supply to system and cycle system through the thermostat.
7. After system has ignited, the meter should read 0.7 micro-amperes or higher. If less than 0.7 micro-amperes, the control may need to be replaced. Clean the sensor probe with emery cloth or fine sandpaper and retest. Check all wiring connections and verify the ignition control is properly grounded before replacing the control.
8. Turn off supply voltage.
9. Disconnect meter from sensor terminal and probe cable.
10. Reconnect probe cable to sensor terminal.
11. Turn on supply voltage.

IGNITOR / FLAME SENSOR

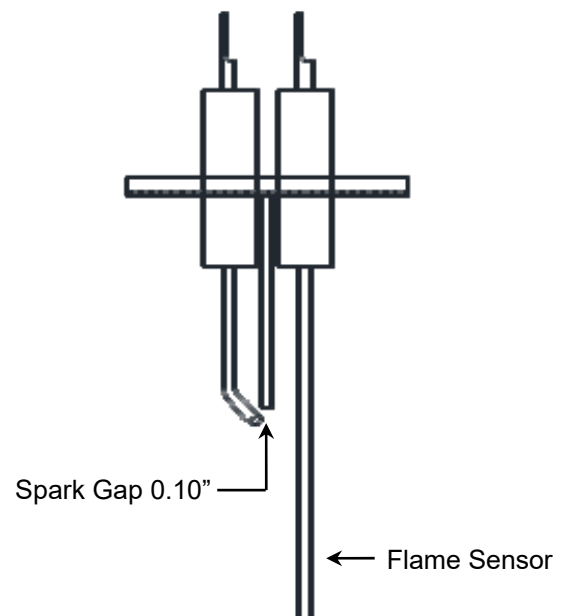

TROUBLESHOOTING FLOW CHART

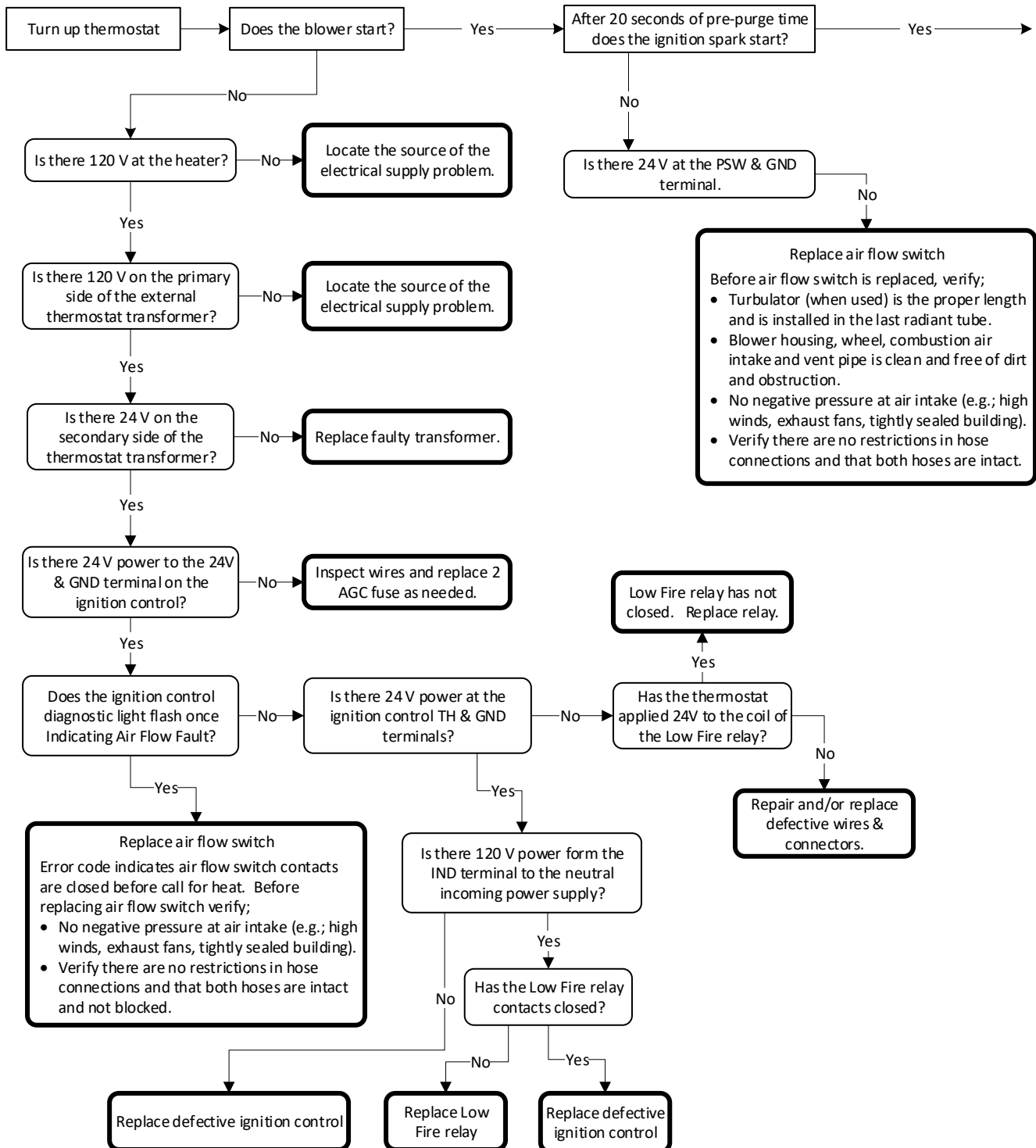

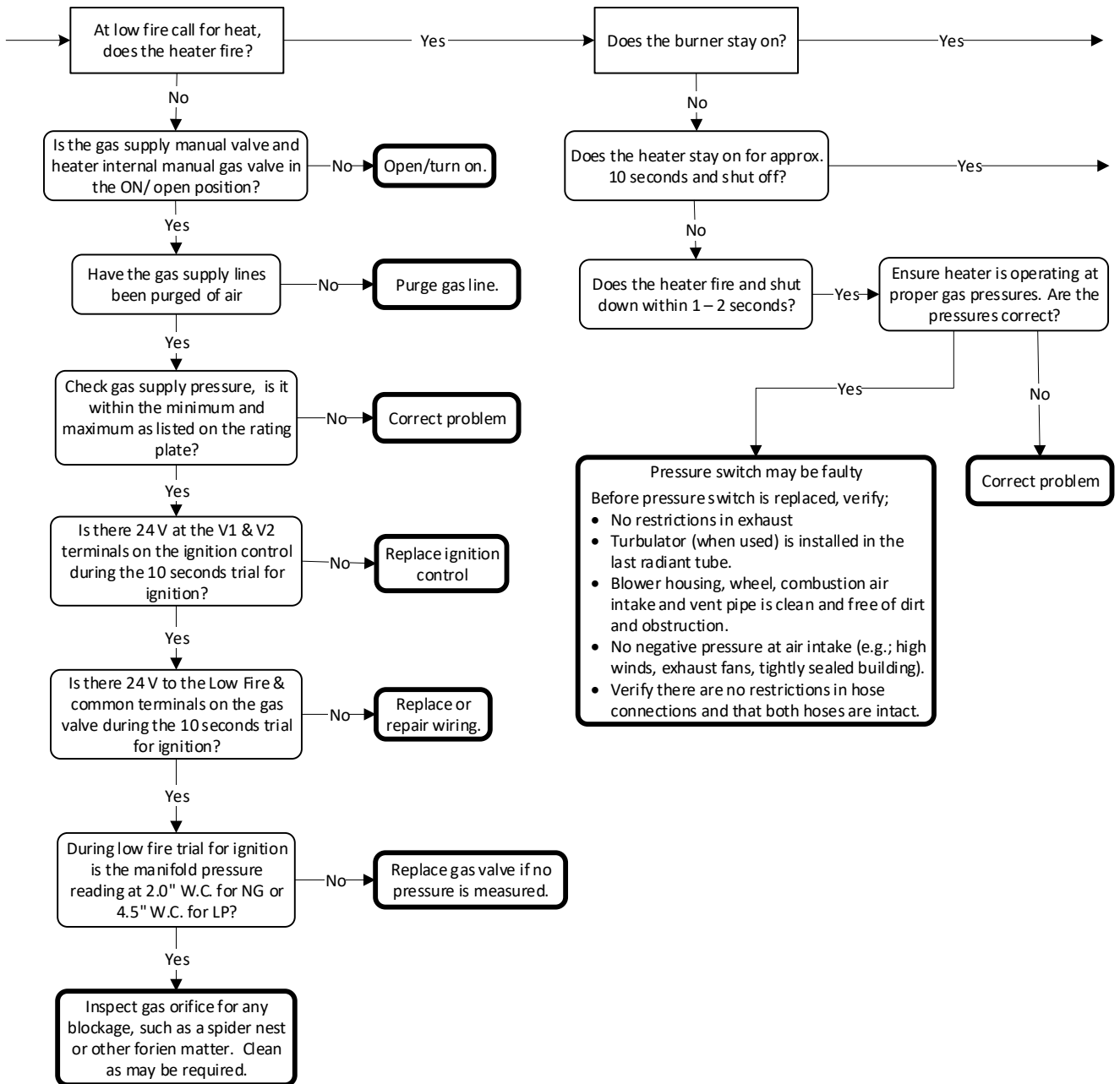

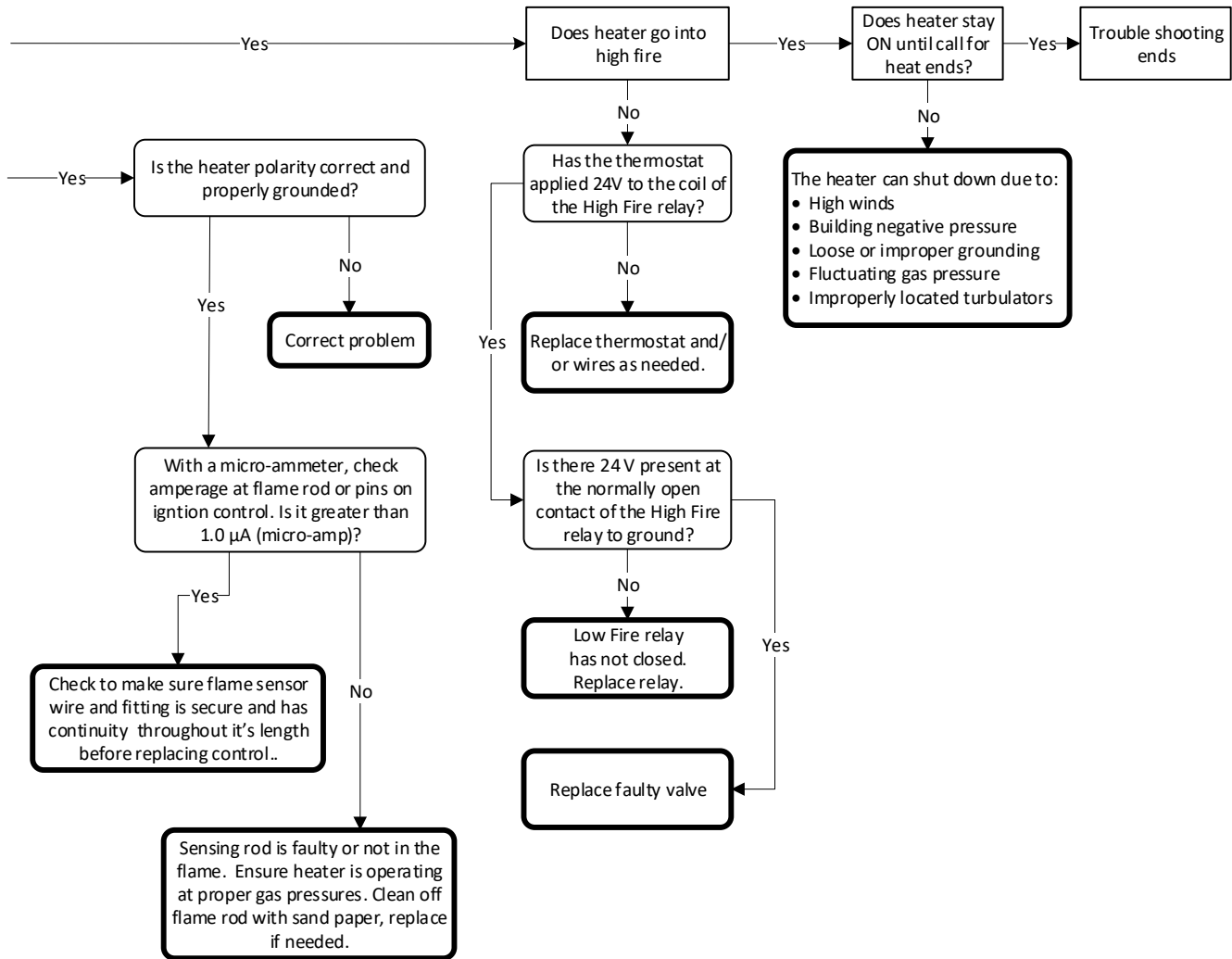

REPLACEMENT PARTS – BURNER ASSEMBLY

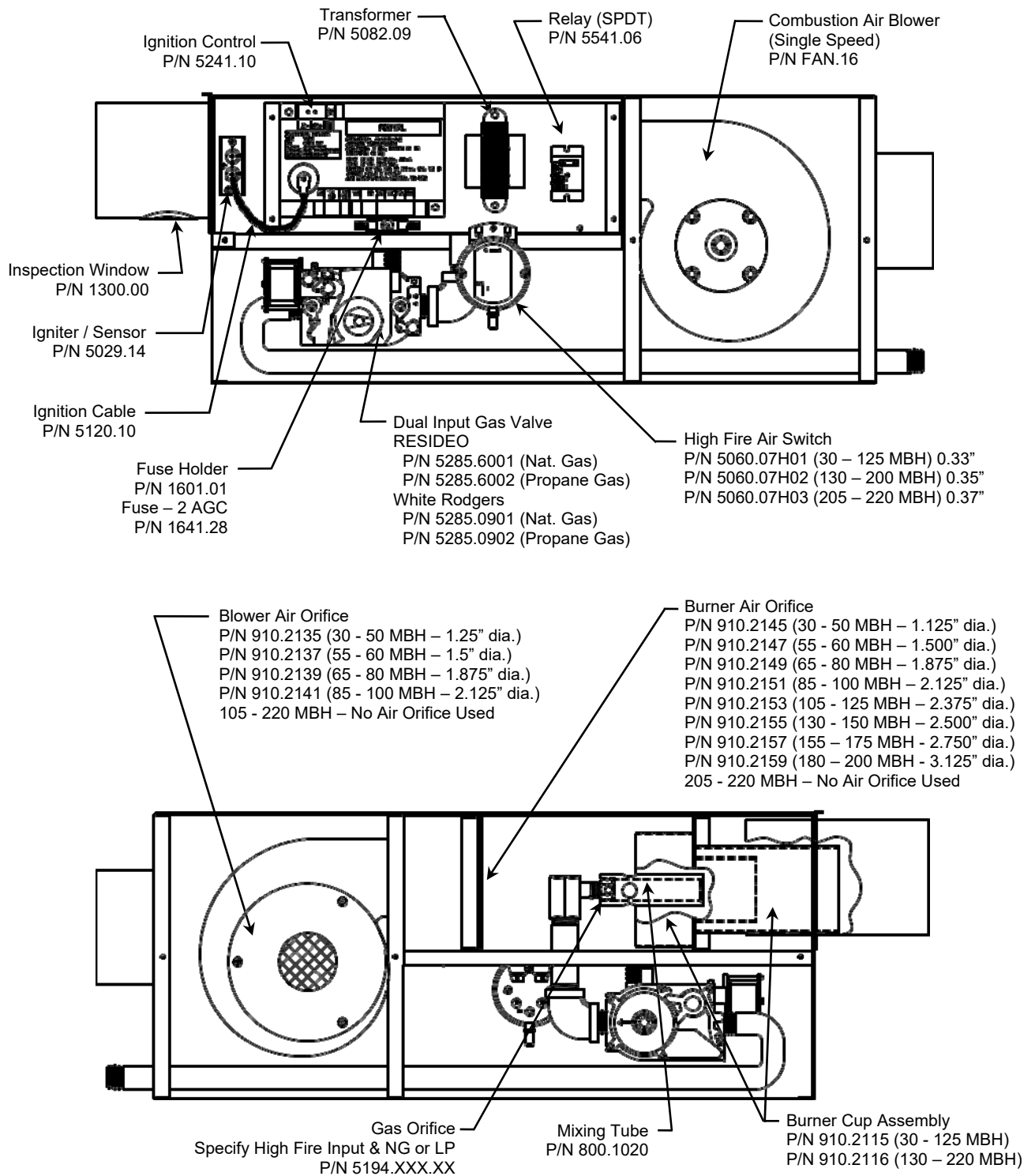



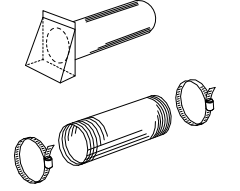

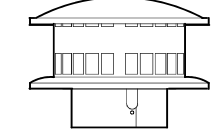

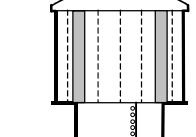

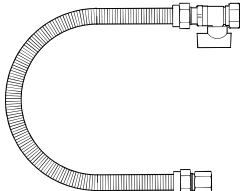
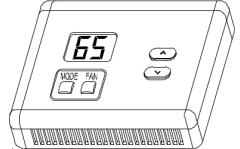
| Part No. | Description | Image |
|--------------------------------|---|---|
| 0314.00

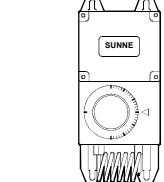
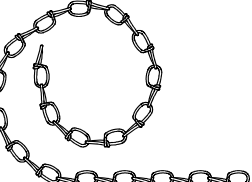
0614.00 | <p>FRESH AIR INLET ASSEMBLY - Weather Proof Inlet 4" dia., 12" long with 24" long PVC coated Aluminum Flex with two hose clamps, 4" diameter. WT. 2.0 lbs.</p> <p>FRESH AIR INLET ASSEMBLY - Weather Proof Inlet 6" dia., 12" long with 48" long PVC coated Aluminum Flex with two hose clamps, 6" diameter. WT. 6.0 lbs.</p> |  |
| 1810.VT.400

1810.VT.600 | <p>ROOF OR WALL VENT - 4" diameter mushroom style round vent. For single wall or "B" Vent. Wt. 0.5 lbs.</p> <p>ROOF OR WALL VENT - 6" diameter mushroom style round vent. For single wall or "B" Vent. Wt. 0.75 lbs.</p> |  |
| 1811.VT.400

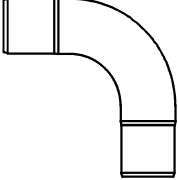
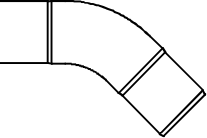
1811.VT.600 | <p>ROOF OR WALL VENT - 4" diameter - High Wind mushroom style round vent. For "B" vent. Wt. 0.5 lbs.</p> <p>ROOF OR WALL VENT - 6" diameter - High Wind mushroom style round vent. For "B" vent. Wt. 0.75 lbs.</p> |  |
| 0317.00

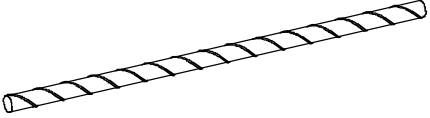
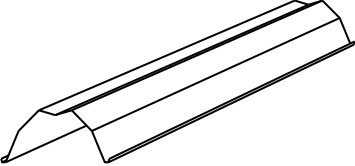
0417.00 | <p>STAINLESS STEEL GAS FLEX - 1/2" NPT (0317.00) or 3/4" NPT (0417.00) fittings and manual gas valve 36" long (Included with each burner – United States Only).
Wt. 7.0 lbs.</p> |  |
| 5490.03 | <p>THERMOSTAT – 24 VAC Two-Stage, 50°F to 90°F
Wt. 1.0 lbs.</p> |  |
| 5491.03 | <p>THERMOSTAT – 24 VAC Two-Stage, 7-Day Programmable, 45°F to 90°F
Wt. 1.0 lbs.</p> |  |
| 5491.05 | <p>THERMOSTAT – 24 VAC & Line voltage Two-Stage, Moisture proof. 40°F to 80°F
Wt. 2.0 lbs.</p> |  |
| 1800.CH.000 | <p>HANGING CHAIN - Double loop hanging chain, 100' - work load rating of 90 lbs.
Wt. 6.5 lbs.</p> |  |

| Part No. | Description | S |
|-------------|---|---|
| 1800.SH.000 | <p>"S" HOOKS - Box of 50 "S" hooks.
WT. 2.0 lbs.</p> |  |
| 0406.AS | <p>90° ELBOW - ALUMINIZED STEEL - 4.0" dia. aluminized steel, 90° elbow. Wt. 3.0 lbs.</p> |  |
| 0436.AS | <p>45° ELBOW - ALUMINIZED - 4.0" dia. aluminized steel, 45° elbow. Wt. 1.5 lbs.</p> |  |
| 0404.16.HT | <p>COMBUSTION TUBE
Reflect-O-Tube 16 Ga., Heat treated aluminized steel combustion tube, 4" O.D., 9'-9" long. Used directly downstream of the burner for inputs up to 175K. One end swaged to fit into standard 0404.HT radiant tube.
Wt. 80 lbs.</p> |  |
| 0404.BHT.16 | <p>COMBUSTION TUBE
Reflect-O-Tube 16 Ga. Heat treated alumatherm steel combustion tube, 4" O.D., 10' long. Used directly downstream of the burner for inputs of 180k thru 220K. Connected to second tube, 0404.16.HT, with a drawband coupler.
Wt. 80 lbs.</p> |  |
| 0404.AS.HT | <p>RADIANT HEAT TUBE - ALUMINIZED/HEAT TREATED - 4.0" dia. aluminized steel heat treated radiant tube, 9'9" long.
Wt. 12.75 lbs.</p> |  |
| 0363.00 | <p>DEEP DISH REFLECTOR - Aluminum, 10' long.
Wt. 5.75 lbs.</p> |  |
| 0464.00 | <p>DEEP DISH COMBINATION HANGER - Heat tube & deep-dish reflector hanger for 4.0" tube, plated 1/4" dia. wire. Wt. 0.75 lb.</p> |  |

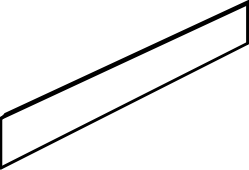
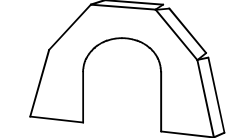
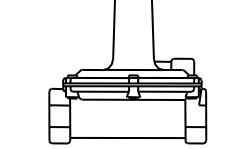
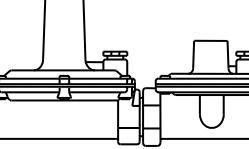
| Part No. | Description | Image |
|-----------|---|---|
| 0465.00 | <p>DEEP DISH REFLECTOR SUPPORT - Intermediate support for deep dish reflector for 4.0" tube, plated 1/4" dia. wire.
Wt. 0.75 lb.</p> |  |
| 0366.00 | <p>SIDE SHIELD - Aluminum side shield. Used on 0363 reflectors, 10' long.
Wt. 5.0 lbs.</p> |  |
| 0363.WH | <p>REFLECTOR END CAP - Aluminum end cap. Used on 0363.00 reflectors.
Wt. 0.50 lbs</p> |  |
| 5221.00 | <p>HIGH PRESSURE REGULATOR - For Natural gas, 2 lbs. to 7.0" W.C., 1/2" NPT
Wt. 1.5 lbs.</p> |  |
| 5221.0015 | <p>HIGH PRESSURE REGULATOR - For Natural gas, 5 lbs. to 7.0" W.C., 1/2" NPT
Wt. 4 lbs.</p> |  |

WARRANTY STATEMENT

Combustion Research Corporation ("CRC") offers the end-use buyers of its products a specific and limited three-year standard Warranty covering the Omega II® product systems or components, the details of which are given below. This Warranty is offered only to the Buyer-For-End-Use ("Buyer") and becomes effective when the product is properly installed and maintained. Proper installation shall be assumed (for purposes of this warranty only) if installation is performed by a qualified installer in accordance with the owner's manual as well as local, state and federal standards.

In addition, to the three-year warranty on all product components, Combustion Research Corporation also offers the Buyer an Extended Warranty on the radiant heater tubing (Infrared Emitter), which is installed as original equipment with a Combustion Research Corporation infrared radiant energy heating system. This Extended Warranty becomes effective (1) on the invoice date of the original equipment from CRC, and (2) the product is properly installed and maintained in accordance with the owner's manual

This Warranty is subject to limitations and conditions which affect the Buyer's rights and which can lead to voidance of the warranty. The Buyer should read and understand these limitations.

DISCLAIMER OF IMPLIED WARRANTIES

(Please Read Carefully)

COMBUSTION RESEARCH CORPORATION ("CRC") DISCLAIMS ANY AND ALL IMPLIED WARRANTIES OF ANY KIND OR DESCRIPTION, INCLUDING WITHOUT LIMITATION WARRANTIES OF MERCHANTABILITY, FITNESS FOR A PARTICULAR PURPOSE, CONDITION, QUALITY OR DURABILITY, WHICH MAY BE PROVIDED BY LAW AS RELATES TO ALL PRODUCTS MANUFACTURED, SOLD, ASSEMBLED AND/OR PROVIDED TO THE ULTIMATE USER, TRANSFEREE, CONTRACTOR, CONSUMER, BUYER AND/OR PERSON UNDER THE LAWS OF THE STATE OF MICHIGAN AND/OR THE UNIFORM COMMERCIAL CODE. THIS DISCLAIMER MEANS NO IMPLIED WARRANTY OF ANY NATURE WHATSOEVER DEALING WITH THE ULTIMATE USE OF THE PRODUCT ASSEMBLED, MANUFACTURED AND/OR SOLD BY CRC SHALL BE GRANTED TO ANY PARTY WHO WITHOUT SAID DISCLAIMER WOULD BE ENTITLED TO BRING AN APPROPRIATE ACTION IN THE COURTS OF THE STATE OF MICHIGAN AS THE LAW SO PROVIDES. THE EXPRESS WRITTEN WARRANTY OF CRC FOR EACH PARTICULAR TRANSACTION SHALL BE THE ONLY EXPRESS WARRANTIES SO PROVIDED AND SHALL BE THE ONLY WARRANTY PROVIDED BY CRC FOR ITS PRODUCTS. THERE ARE NO WARRANTIES WHATSOEVER BEYOND THE DESCRIPTION ON THE FACE HEREOF.

DISCLAIMER OF DAMAGES

(Please Read Carefully)

IN NO EVENT SHALL CRC BE LIABLE FOR SPECIAL, INDIRECT, CONSEQUENTIAL OR INCIDENTAL DAMAGES OF ANY TYPE OR DESCRIPTION WHETHER ARISING UNDER CONTRACT, WARRANTY, TORT, NEGLIGENCE, STRICT LIABILITY OR ANY OTHER THEORY OF LIABILITY. SUCH DAMAGES INCLUDE, BUT ARE NOT LIMITED TO, LOSS OF PROFITS, LOSS OF USE OF THE PRODUCTS, DAMAGE TO PROPERTY, INCONVENIENCE AND CLAIMS OF THIRD PARTIES. SOME STATES DO NOT ALLOW THE EXCLUSION OR LIMITATION OF INCIDENTAL OR CONSEQUENTIAL DAMAGES, OR ANY LIMITATION OF INCIDENTAL OR CONSEQUENTIAL DAMAGES OR ANY LIMITATIONS ON HOW LONG AN IMPLIED WARRANTY LASTS, SO THE ABOVE EXCLUSION OR LIMITATION MAY NOT APPLY TO YOU. THIS WARRANTY GIVES YOU SPECIFIC LEGAL RIGHTS WHICH VARY FROM STATE TO STATE. HOWEVER, TO THE EXTENT PROVIDED BY LAW, MICHIGAN LAW CONTROLS ALL RIGHTS AND OBLIGATIONS HEREUNDER.

LIMITATIONS AND CONDITIONS FOR STANDARD WARRANTY

The express written Warranty is a representation by CRC that the products, including all components, purchased by the Buyer from CRC or an authorized CRC representative are free from defects in material and workmanship. This Warranty applies to defects which are discovered either upon receipt of the product, or up to three (3) years after receipt of the product or CRC's invoice date, whichever event last occurs. If any such defect is found and the Buyer has satisfied the warranty requirement, and the warranty is not voided under any of the following conditions, CRC will replace free-of-charge, the defective part or parts. However it is not CRC's obligation to find, remove, or transport the defective part or parts. Further, it is not CRC's obligation to install or to pay for installation of any replacement part or parts. Repair or replacement of defective part or parts will only be done after CRC has determined in its sole judgment that the warranty applies.

LIMITATIONS AND CONDITIONS FOR EXTENDED 10 YEAR WARRANTY

The Extended Warranty is a special offer made by Combustion Research Corporation (CRC) to Buyers-For-End-use of CRC products to give them an extra term of replacement part protection. The Extended Warranty covers the infrared emitter tubing. The infrared tubing is guaranteed by CRC against internally created rust through corrosion (which is caused by the condensation of products of combustion inside the emitter tube when the flue gas temperature is allowed to fall below the dew/condensation point) for 10 years from CRC's invoice date. If any defect is found during this period, and if the Buyer-For-End-Use has satisfied the Warranty and Extended Warranty requirements, and if the warranty is not voided under any of the following conditions, CRC's obligation is either repair the defective part or to furnish the Buyer-For-End-Use with a

- CONTINUED-

replacement part or parts. As with the Standard Warranty, it is not CRC's obligation to find, remove or transport the defective part or parts, or to pay for finding, removing, or transporting such part or parts, and it is not CRC's obligation to install or pay for installation of the replacement part or parts. Again, it is the Buyer's obligation to send the part or parts freight pre-paid to CRC.

LIMITATIONS ON STANDARD AND EXTENDED 10 YEAR WARRANTY

These Warranties are the only warranties offered by Combustion Research Corporation (CRC) and are in lieu of all other warranties either express or implied. CRC shall not be liable for any special, incidental or consequential damage, such as damage to a building or persons or things within a building due to any kind of radiant energy heating system failure. In addition, the Standard and Extended Warranties apply only to those products which are shipped to and installed in the United States.

ARBITRATION

In the event any Buyer, user, subsequent owner, transferee, installer, purchaser and/or ultimate customer experiences any problem, difficulty and/or has a complaint dealing with the use, installation and/or operation of the products sold, delivered and/or manufactured by CRC under the terms and provisions of any purchase order, contract, invoice or other document, then the differences between that person or entity and CRC shall be amicably resolved. In the event a resolution of the differences between the parties is unable to be accomplished, said matter shall be resolved through final and binding arbitration under the laws of the State of Michigan. The party complaining shall select, appoint and pay for an arbitrator. CRC shall select, appoint and pay for an arbitrator, and the two (2) arbitrators so selected shall agree upon and appoint a third impartial arbitrator. The dispute and/or matter of controversy shall be submitted to the arbitrators who by majority vote shall render a final and binding decision dealing with the controversy in existence between the parties. Said decision shall be enforceable in a Michigan Court maintaining jurisdiction over said matter under the requisite provisions of Michigan law. The costs of the impartial arbitrator shall be paid one-half (1/2) by the complaining party and one-half (1/2) by CRC.

MICHIGAN LAW TO GOVERN

This contract and/or document dealing with the purchase sale and/or installation of products sold and/or manufactured by CRC shall be governed by the laws of the State of Michigan, both as to its interpretation and performance. The place of this contract, its situs and forum shall at all times be the State of Michigan. All matters relating to the validity, construction and enforcement of this contract shall be determined in the appropriate courts maintaining jurisdiction over all controversies in the State of Michigan.

VOIDING OF WARRANTIES

Each of the following listed events, conditions, acts or omissions by any person or entity may void the Warranty:

1. Improper installation; i.e., installation which is not in accordance with the instructions in the service and installation manual.
2. Running the burner(s) with intake combustion air drawn from an atmosphere which is contaminated with halogenated hydrocarbons, fluorocarbons, or other corrosive substances.
3. Relocation or reinstallation of the product or system.
4. Use of electrical power having voltages, frequencies or transients which exceed product or system ratings.
5. Physical abuse or neglect to the product system or components of the system; i.e., allowing the product system to operate with broken or damaged system components.
6. Damage to the product system or components of the product system by fire, flood, earthquake, or act of God.
7. Removal of the serial number or nameplate.
8. Refusal to permit inspection and/or service of the product system or parts by an authorized CRC representative.
9. Repair or replacement of any product components or other heating components which have been repaired or replaced with other than factory parts.
10. Designing or allowing the system to run with a "short cycle" or continuous condensing mode; i.e., using low voltage temperature controls without a minimum eight (8) minute run time which would allow the startup condensate to collect in the tubing system.

The determination and evaluation of any or all of the above conditions shall be according to the sole and exclusive discretion of CRC, and/or its authorized representative. If, upon examination, either CRC or its authorized representative determines that the defect or defects are caused by any of the above, the warranty obligation of CRC shall not be honored. No representative of CRC, other than an officer, has authority to change or extend these provisions or warranties. Changes or extensions shall be binding only if confirmed in writing by CRC's duly authorized executive officers. Product systems installed by CRC, or its authorized representatives shall be or presumed to be properly installed and to be free of any and all conditions which might void the warranty at the time of installation. All product components or systems repaired or replaced are warranted under the same terms and conditions as the original Warranty, but only for the remaining time under the original warranty. No action shall be brought for any breach of this warranty more than one (1) year after the cause of action for such breach arises. Nothing herein shall be construed to extend any warranty beyond the stated periods. CRC shall not be liable for any default or delay in performance by it in accordance with these warranties which delay or performance is caused by contingency beyond its control including but not limited to war, government restriction or restraint, strikes, fire, floods, unavailability of raw material, and acts of God.

This page intentionally left blank

In storage areas where stacking of materials may occur, the installer must provide signs that specify the maximum stacking height so as to maintain the required clearance to combustibles. The following is a temporary sign that can be used until a permanent label is obtained from your representative or Combustion Research Corporation - Request P/N 5566.006. Attach this label near the Omega II® heater or by the thermostat.



COMBUSTION RESEARCH CORP.

Infrared Heating Systems

⚠ WARNING



Fire Hazard

Some objects can catch fire or explode when placed close to the heater.

Keep all flammable objects, liquids and vapors the required clearance to combustibles away from the heater.

Failure to follow these instructions can result in death, injury or property damage.

**Maintain _____ clearance
to the side and
_____ clearance below the
heater from vehicles and
combustible materials.**

Read and understand the Installation, Operation and Maintenance manual before installation, operation or service.

Know your heater part number, and BTU input. The Part Number and BTU Input and clearance to combustible information can be found on the burner assembly and in the Installation, Operation and Maintenance manual.

Write the largest clearance dimensions with permanent marker, according to the heater used, in the open spaces above.

Combustion Research Corp. - 2516 Leach Rd. - Rochester Hills, MI 48309-3555
Telephone: 248.852.3611 Fax: 248.852.9165
www.combustionresearch.com

Printed in U.S.A

Revision Date:

Rev. 0

P/N 5566.006

